

# CL-N-D トルクレンチ Torque Wrench

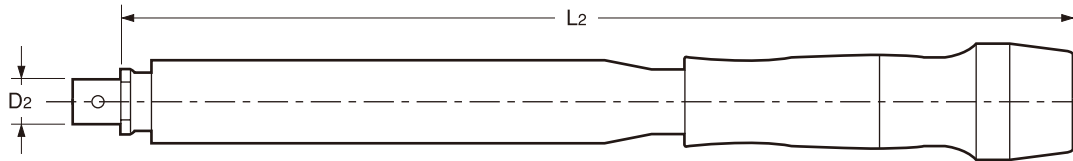

商品コード Code	型式 Model	トルク調整範囲 Torque range	D2	L2	kg	スパナヘッド Spanner head
3154 01010000	CL 25N5 × 10D	5 ~ 25Nm	10	205	0.21	SH-11-10, SH-14-10, SH-23-10, SH-0R-10
3154 00020000	CL 50N × 15D	10 ~ 50Nm	15	219	0.40	SH-1A-15, SH-25-15, SH-1R-15
3154 00030000	CL 100N × 15D	20 ~ 100Nm	15	294	0.59	SH-3A-15, SH-4A-15, SH-5A-15, SH-34-15, SH-45-15 SH-3R-15, SH-4R-15, SH-5R-15
3154 00040000	CL 200N × 19D	40 ~ 200Nm	19	435		SH-6A-19, SH-52-19

トルク設定は必ず取扱説明書に従い、スパナヘッド指定のトルクでご使用ください。  
Please use spanner head with correct torque in accordance with manual.

## SH スパナヘッド Spanner Head

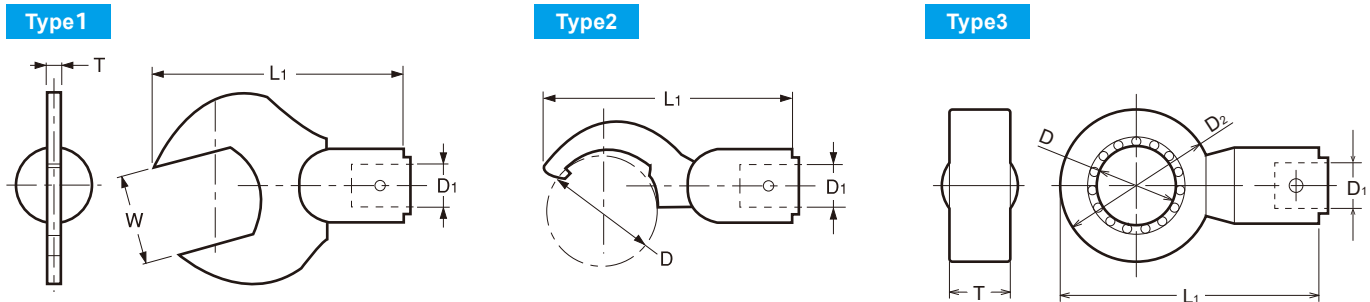

商品コード Code	型式 Model	Type	W	T	D	D1	D2	L1	kg	トルクレンチ Torque wrench	キャップ Nut		
											型式 Model	タップシャンク径 Tap shank dia.	設定トルク Torque
3155 00010010	SH-0R-10	3	—	16	20	10	40	61.5		CL 25N5 x 10D	HDP-07R	—	10 ~ 15Nm
3155 00010115	SH-1R-15	3	—	20	26	15	50	85		CL 50N x 15D	HDP-09R, GDP-09R	—	30 ~ 35Nm
3155 00010315	SH-3R-15	3	—	20	30	15	56	88		CL100N x 15D	HDP-12R, GDP-12R	—	35 ~ 40Nm
3155 00010415	SH-4R-15	3	—	20	35	15	60	90		CL100N x 15D	HDP-16R, GDP-16R	—	40 ~ 45Nm
3155 00010515	SH-5R-15	3	—	20	46	15	72	96		CL100N x 15D	HDP-22R, GDP-22R	—	55 ~ 60Nm
3150 00001110	SH-11-10	1	11	6.5	—	10	—	51	0.06	CL 25N5 x 10D	ERP-8, ERP-8T	—	5 ~ 7Nm
3150 00001410	SH-14-10	1	14	6.5	—	10	—	52	0.20	CL 25N5 x 10D	ERP-11S	—	15 ~ 20Nm
3150 00002310	SH-23-10	2	—	—	23	10	—	59	0.05	CL 25N5 x 10D	HDP-07A	—	10 ~ 15Nm
3150 00000115	SH-1A-15	1	24	4.5	—	15	—	78	0.14	CL 50N x 15D	HDP-09, KDP-1916, HTP-09	—	30 ~ 35Nm
3150 00000315	SH-3A-15	1	30	4.5	—	15	—	82.5	0.20	CL100N x 15D	HDP-12, KDP-2422	—	35 ~ 40Nm
3150 00000415	SH-4A-15	1	33	4.5	—	15	—	84	0.25	CL100N x 15D	HDP-16, KDP-2825, HTP-16	—	40 ~ 45Nm
3150 00000515	SH-5A-15	1	42	5.5	—	15	—	89	0.23	CL100N x 15D	HDP-22, KDP-3632, HTP-22	—	55 ~ 60Nm
3150 00000619	SH-6A-19	2	—	—	66	19	—	118.5	0.25	CL200N x 19D	HDP-32	—	80 ~ 90Nm
3150 00002515	SH-25-15	2	—	—	29	15	—	77	0.11	CL 50N x 15D	GDP-09 GDP-12	—	30 ~ 35Nm 35 ~ 40Nm
3150 00003415	SH-34-15	2	—	—	38	15	—	82	0.13	CL100N x 15D	ERP-16T	ø4 ~ ø6.2 (mm) ø0.168 ~ ø0.318 (inch)	30 ~ 35Nm
												ø7 ~ ø9 (mm)	40 ~ 50Nm
											GDP-16	—	40 ~ 45Nm
3150 00004515	SH-45-15	2	—	—	49	15	—	86	0.10	CL100N x 15D	GDP-22	—	55 ~ 60Nm
3150 00005219	SH-52-19	2	—	—	55	19	—	104.5	0.22	CL200N x 19D	ERP-32T	—	100~105Nm