

HP-H

High-speed type

30,000min⁻¹

Hyper Spindle (Speed Inserter)

- Enables high speed cutting operation by multiplying the machine spindle speed at the cutting edge. (Max30000min⁻¹)

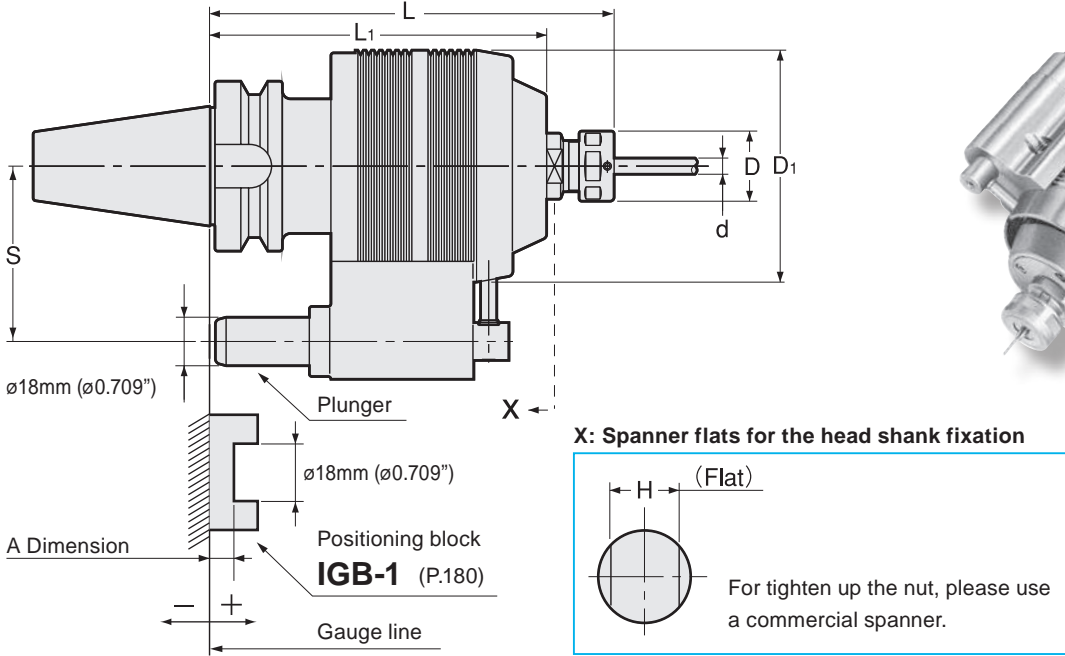

Unit : Metric

Code	Model	L	S	d	D	D1	L1	Nut	H	Speed boost	MAX min ⁻¹	kg
2520 1 ※ 307150	BT40 -HP07H -150 -※	150	65	0.5 ~ 7.0	23	86	125	HDP-07A	16	5	30,000	3.4
2520 1 ※ 307180	-180 -※	180	65	0.5 ~ 7.0	23	86	125	HDP-07A	16	5	30,000	3.5
2520 1 ※ 309150	BT40 -HP09H -150 -※	150	65	2.6 ~ 9.0	26	86	125	HDP-09	21	5	30,000	3.4
2520 1 ※ 309180	-180 -※	180	65	2.6 ~ 9.0	26	86	125	HDP-09	21	5	30,000	3.5
2520 1 ※ 312165	BT40 -HP12H -165 -※	165	65	2.6 ~ 12.0	32	86	125	HDP-12	21	5	30,000	3.5
2520 1 ※ 312180	-180 -※	180	65	2.6 ~ 12.0	32	86	125	HDP-12	21	5	30,000	3.6
2520 1 ※ 507150	BT50 -HP07H -150 -※	150	80	0.5 ~ 7.0	23	86	125	HDP-07A	16	5	30,000	5.9
2520 1 ※ 507180	-180 -※	180	80	0.5 ~ 7.0	23	86	125	HDP-07A	16	5	30,000	6.0
2520 1 ※ 509150	BT50 -HP09H -150 -※	150	80	2.6 ~ 9.0	26	86	125	HDP-09	21	5	30,000	5.9
2520 1 ※ 509180	-180 -※	180	80	2.6 ~ 9.0	26	86	125	HDP-09	21	5	30,000	6.0
2520 1 ※ 512165	BT50 -HP12H -165 -※	165	80	2.6 ~ 12.0	32	86	125	HDP-12	21	5	30,000	6.0
2520 1 ※ 512180	-180 -※	180	80	2.6 ~ 12.0	32	86	125	HDP-12	21	5	30,000	6.0

1. When ordering, please specify the plunger number (No.1~No.5).
2. Plunger is adjustable. Please refer to a chart on the right.
3. Collet and spanner are sold separately.
4. Use AA class collet only.

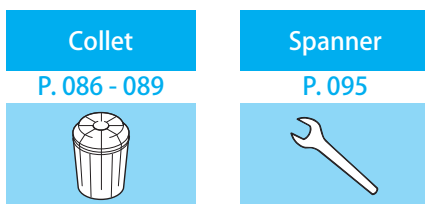

Plunger table					
Model	Plunger No. A				
	No.1	No.2	No.3	No.4	No.5
All Model	+24~+15.1	+15~+6.1	+6~-2.9	-3~-11.9	-12~-20.9

Holder	Collet	d	Spanner
HP07H	FDC-07AA	0.5 ~ 7.0	S-0
HP09H	FDC-09AA	2.6 ~ 9.0	S-1L
HP12H	FDC-12AA	2.6 ~ 12.0	S-3L

Ordering Example

BT40 - HP 07 H - 150 - 1

Shank size Max. collet I.D. Projection length (L) Plunger No.

HP-H

High-speed type

30,000min⁻¹

Hyper Spindle (Speed In creaser)

- Enables high speed cutting operation by multiplying the machine spindle speed at the cutting edge. (Max30000min⁻¹)

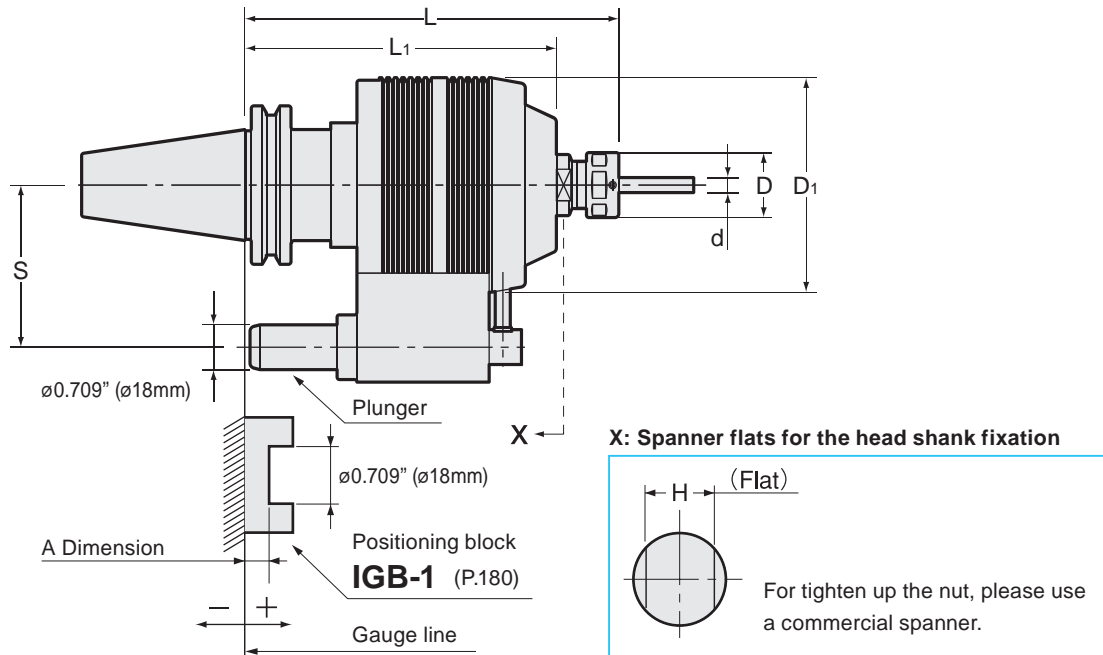

Unit : Inch

Code	Model	d	L	L1	D	D1	S	H	Gear ratio	MAX rpm	kg	Nut
2070 1 ※ 407150	CAT40 -HP07H -150 -※	0.020 - 0.276	5.906	4.921	0.906	3.386	2.559 (65mm)	0.630 (16mm)	5:1	30,000	3.3	HDP-07A
2070 1 ※ 407180	-180 -※	0.020 - 0.276	7.087	4.921	0.906	3.386	2.559 (65mm)	0.630 (16mm)	5:1	30,000		HDP-07A
2070 1 ※ 409150	CAT40 -HP09H -150 -※	0.098 - 0.354	5.906	4.921	1.024	3.386	2.559 (65mm)	0.827 (21mm)	5:1	30,000		HDP-09
2070 1 ※ 409180	-180 -※	0.098 - 0.354	7.087	4.921	1.024	3.386	2.559 (65mm)	0.827 (21mm)	5:1	30,000		HDP-09
2070 1 ※ 412165	CAT40 -HP12H -165 -※	0.098 - 0.472	6.496	4.921	1.260	3.386	2.559 (65mm)	0.827 (21mm)	5:1	30,000		HDP-12
2070 1 ※ 412180	-180 -※	0.098 - 0.472	7.087	4.921	1.260	3.386	2.559 (65mm)	0.827 (21mm)	5:1	30,000		HDP-12
2070 1 ※ 507150	CAT50 -HP07H -150 -※	0.020 - 0.276	5.906	4.921	0.906	3.386	3.150 (80mm)	0.630 (16mm)	5:1	30,000		HDP-07A
2070 1 ※ 507180	-180 -※	0.020 - 0.276	7.087	4.921	0.906	3.386	3.150 (80mm)	0.630 (16mm)	5:1	30,000		HDP-07A
2070 1 ※ 509150	CAT50 -HP09H -150 -※	0.098 - 0.354	5.906	4.921	1.024	3.386	3.150 (80mm)	0.827 (21mm)	5:1	30,000		HDP-09
2070 1 ※ 509180	-180 -※	0.098 - 0.354	7.087	4.921	1.024	3.386	3.150 (80mm)	0.827 (21mm)	5:1	30,000		HDP-09
2070 1 ※ 512165	CAT50 -HP12H -165 -※	0.098 - 0.472	6.496	4.921	1.260	3.386	3.150 (80mm)	0.827 (21mm)	5:1	30,000		HDP-12
2070 1 ※ 512180	-180 -※	0.098 - 0.472	7.087	4.921	1.260	3.386	3.150 (80mm)	0.827 (21mm)	5:1	30,000		HDP-12

Collet	Spanner	Plunger No.					
		No.1	No.2	No.3	No.4	No.5	
P.086-089	P.095	All Type	A +0.594 ~ +0.945	A +0.240 ~ +0.591	A -0.114 ~ +0.236	A -0.469 ~ -0.118	A -0.823 ~ -0.472

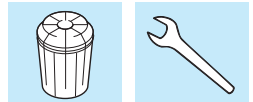

1. When ordering, please specify the plunger number (No.1~No.5).
2. Plunger is adjustable. Please refer to a chart on the right.
3. Collet and spanner are sold separately.
4. Use AA class collet only.

Ordering Example

CAT40 - HP 07 H - 150 - 1
 Shank size Max. collet I.D. Projection length (L) Plunger No.