

Face Mill Arbor

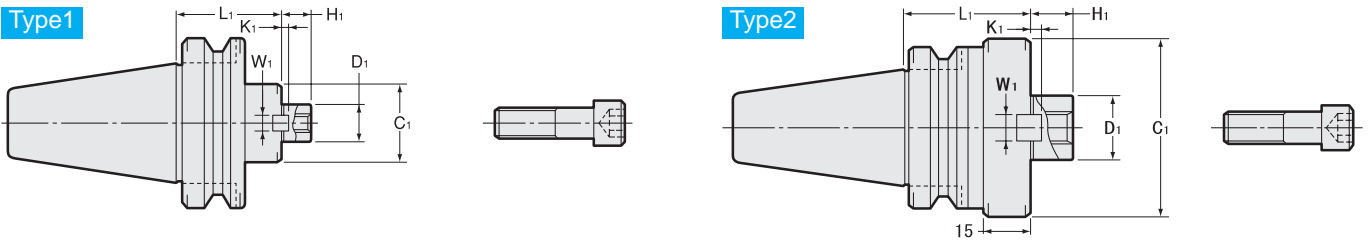

Metric Sizes

Unit : Metric

| Code | Model | Type | D1 (h6) | L1 | C1 | H1 | W1 | K1 | kg | Clamp Bolt JIS B1176 | Cutter dia. example |
|---------------|------------------------|------|---------|-----|----|----|----|----|-----|----------------------|---------------------|
| 0770 03122045 | BT30 -FMC22 -45 | 1 | 22 | 45 | 45 | 18 | 10 | 5 | 0.8 | M10 | 50 63 |
| 0770 03322045 | BT40 -FMC22 -45 | 1 | 22 | 45 | 45 | 18 | 10 | 5 | 1.3 | M10 | 50 63 |
| 0770 03322090 | -90 | 1 | 22 | 90 | 45 | 18 | 10 | 5 | 1.9 | M10 | 50 63 |
| 0770 03327060 | BT40 -FMC27 -60 | 2 | 27 | 60 | 70 | 20 | 12 | 6 | 2.0 | M12 | 80 |
| 0770 03327090 | -90 | 2 | 27 | 90 | 70 | 20 | 12 | 6 | 2.8 | M12 | 80 |
| 0770 03332060 | BT40 -FMC32 -60 | 2 | 32 | 60 | 85 | 22 | 14 | 7 | 2.3 | M16 | 100 |
| 0770 03332075 | -75 | 2 | 32 | 75 | 85 | 22 | 14 | 7 | 2.7 | M16 | 100 |
| 0770 03522060 | BT50 -FMC22 -60 | 1 | 22 | 60 | 45 | 18 | 10 | 5 | 4.0 | M10 | 50 63 |
| 0770 03522105 | -105 | 1 | 22 | 105 | 45 | 18 | 10 | 5 | 4.6 | M10 | 50 63 |
| 0770 03522150 | -150 | 1 | 22 | 150 | 45 | 18 | 10 | 5 | 5.2 | M10 | 50 63 |
| 0770 03527045 | BT50 -FMC27 -45 | 1 | 27 | 45 | 70 | 20 | 12 | 6 | 4.0 | M12 | 80 |
| 0770 03527090 | -90 | 1 | 27 | 90 | 70 | 20 | 12 | 6 | 5.4 | M12 | 80 |
| 0770 03527150 | -150 | 1 | 27 | 150 | 70 | 20 | 12 | 6 | 7.2 | M12 | 80 |
| 0770 03532045 | BT50 -FMC32 -45 | 1 | 32 | 45 | 85 | 22 | 14 | 7 | 4.2 | M16 | 100 |
| 0770 03532075 | -75 | 1 | 32 | 75 | 85 | 22 | 14 | 7 | 5.5 | M16 | 100 |
| 0770 03532105 | -105 | 1 | 32 | 105 | 85 | 22 | 14 | 7 | 6.9 | M16 | 100 |

Clamp bolt is Included.

Ordering Example

BT30 - FMC 27 - 45
 Shank size D1 Projection length (L)

Inch Sizes

Unit : Metric

| Code | Model | Type | D1 (h6) | L1 | C1 | H1 | W1 | K1 | kg | Clamp Bolt JIS B1176 | Cutter dia. example |
|---------------|--------------------------|------|---------|-----|----|----|------|----|-----|----------------------|---------------------|
| 0770 04125060 | BT30 -FMC25.4 -60 | 2 | 25.4 | 60 | 70 | 20 | 9.5 | 5 | 1.3 | M12 | 80 |
| 0770 04325060 | BT40 -FMC25.4 -60 | 2 | 25.4 | 60 | 70 | 20 | 9.5 | 5 | 2.0 | M12 | 80 |
| 0770 04325090 | -90 | 2 | 25.4 | 90 | 70 | 20 | 9.5 | 5 | 2.7 | M12 | 80 |
| 0770 04338060 | BT40 -FMC38.1 -60 | 2 | 38.1 | 60 | 85 | 22 | 15.9 | 7 | 2.3 | M16 | 100 |
| 0770 04338075 | -75 | 2 | 38.1 | 75 | 85 | 22 | 15.9 | 7 | 2.6 | M16 | 100 |
| 0770 04525045 | BT50 -FMC25.4 -45 | 1 | 25.4 | 45 | 70 | 20 | 9.5 | 5 | 4.1 | M12 | 80 |
| 0770 04525090 | -90 | 1 | 25.4 | 90 | 70 | 20 | 9.5 | 5 | 5.4 | M12 | 80 |
| 0770 04525150 | -150 | 1 | 25.4 | 150 | 70 | 20 | 9.5 | 5 | 7.2 | M12 | 80 |
| 0770 04538045 | BT50 -FMC38.1 -45 | 1 | 38.1 | 45 | 85 | 22 | 15.9 | 7 | 4.3 | M16 | 100 |
| 0770 04538075 | -75 | 1 | 38.1 | 75 | 85 | 22 | 15.9 | 7 | 5.5 | M16 | 100 |
| 0770 04538105 | -105 | 1 | 38.1 | 105 | 85 | 22 | 15.9 | 7 | 6.9 | M16 | 100 |

Clamp bolt is Included.

Ordering Example

BT30 - FMC 25.4 - 60
 Shank size D1 Projection length (L)

Face Mill Arbor

- For SANDVIK T-MAX shoulder face mill.

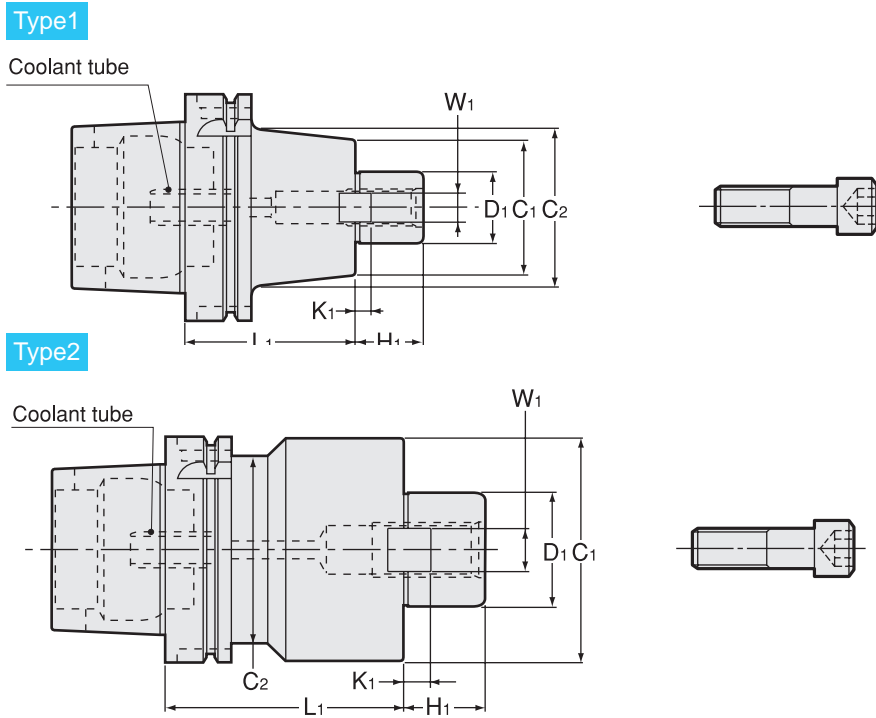

- Coolant tube is included.

| Metric Sizes | | | | | | | | | | | | Unit : Metric | |
|---------------|-----------------------|------|------|-----|----|----|----|------|----|-----|------------------------|---------------------|--|
| Code | Model | Type | D1 | L1 | H1 | C1 | C2 | W1 | K1 | kg | Clamp Bolt (JIS B1176) | Cutter dia. example | |
| 5340 13222045 | HSK40A -FMC22 -45 | 2 | 22 | 45 | 18 | 45 | 31 | 10 | 5 | | M10 | 50 63 | |
| 5340 13225060 | HSK40A -FMC25.4 -60 | 2 | 25.4 | 60 | 20 | 70 | 34 | 9.5 | 5 | | M12 | 80 | |
| 5340 14222060 | HSK50A -FMC22 -60 | 2 | 22 | 60 | 18 | 45 | 42 | 10 | 5 | | M10 | 50 63 | |
| 5340 14225060 | HSK50A -FMC25.4 -60 | 2 | 25.4 | 60 | 20 | 70 | 42 | 9.5 | 5 | | M12 | 80 | |
| 5340 35022060 | HSK63A -FMC22 -60 | 1 | 22 | 60 | 18 | 45 | 45 | 10 | 5 | 1.1 | M10 | 50 63 | |
| 5340 35025060 | HSK63A -FMC25.4 -60 | 2 | 25.4 | 60 | 20 | 70 | 53 | 9.5 | 5 | | M12 | 80 | |
| 5340 35027060 | HSK63A -FMC27 -60 | 2 | 27 | 60 | 20 | 70 | 53 | 12 | 6 | 1.6 | M12 | 80 | |
| 5340 35038060 | HSK63A -FMC38.1 -60 | 2 | 38.1 | 60 | 22 | 85 | 48 | 15.9 | 7 | | M16 | 100 | |
| 5340 37022090 | HSK100A -FMC22 -90 | 1 | 22 | 90 | 18 | 45 | 85 | 10 | 5 | 3.7 | M10 | 50 63 | |
| 5340 37025090 | HSK100A -FMC25.4 -90 | 1 | 25.4 | 90 | 20 | 70 | 85 | 9.5 | 5 | | M12 | 80 | |
| 5340 37027090 | HSK100A -FMC27 -90 | 1 | 27 | 90 | 20 | 70 | 85 | 12 | 6 | | M12 | 80 | |
| 5340 37038105 | HSK100A -FMC38.1 -105 | 1 | 38.1 | 105 | 22 | 85 | 85 | 15.9 | 7 | | M16 | 100 | |

Clamp bolt is Included.

Ordering Example

HSK63A - FMC 25.4 - 60
 Shank size D1 Projection length (L)