

FMH

オイルホール穴付カッター用 フェイスミルアーバ

Face Mill Arbor (For Cutters with Oil Hole)

- ホルダイナーロー端面部からオイルホール穴付カッターへクーラント供給できます。
Coolant flows from the end face of centering location to cutter with oil hole.

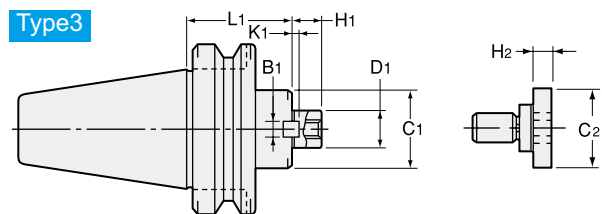
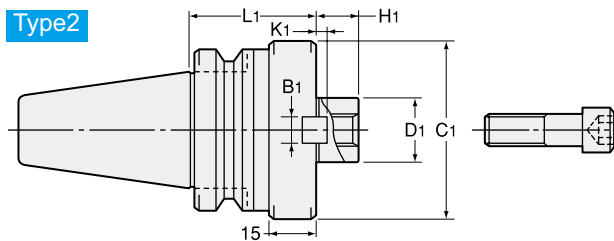
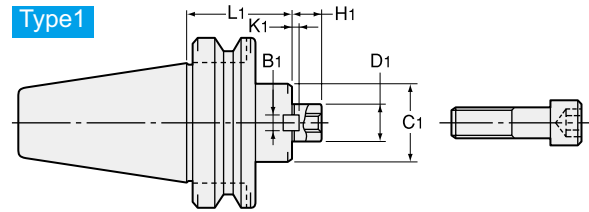
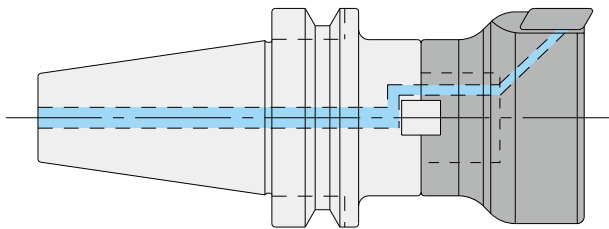

商品コード Code	型式 Model	Type	D1 (h6)	L1	C1	H1	B1	K1	C2	H2	—	締付ボルト Clamp bolt
0770 06116045	BT30 -FMH16 -34 -45	1	16	45	34	17	8	5	—	—	19,120	M8
0770 06116060		1	16	60	34	17	8	5	—	—	19,120	
0770 06122045	-FMH22 -47 -45	2	22	45	47	18	10	5.6	—	—	19,550	M10
0770 06122060		2	22	60	47	18	10	5.6	—	—	19,550	
0770 06123045	-FMH22.225 -47 -45	2	22.225	45	47	17	8	3.5	—	—	19,850	M10
0770 06123060		2	22.225	60	47	17	8	3.5	—	—	19,850	
0770 06125060	-FMH25.4 -60 -60	2	25.4	60	60	22	9.5	5	—	—	20,150	M12
0770 06127060		2	27	60	60	20	12	6	—	—	22,500	
0770 06316045	BT40 -FMH16 -34 -45	1	16	45	34	17	8	5	—	—	19,910	M8
0770 06316060		1	16	60	34	17	8	5	—	—	19,910	
0770 06316075	-75 -90	1	16	75	34	17	8	5	—	—	20,350	M8
0770 06316090		1	16	90	34	17	8	5	—	—	20,350	
0770 06322045	-FMH22 -47 -45	1	22	45	47	18	10	5.6	—	—	23,210	M10
0770 06322060		1	22	60	47	18	10	5.6	—	—	23,650	
0770 06322075	-75 -90	1	22	75	47	18	10	5.6	—	—	23,870	M10
0770 06322090		1	22	90	47	18	10	5.6	—	—	24,310	
0770 07322045	-60 -45	1	22	45	60	18	10	5.6	—	—	23,210	M10
0770 07322060		1	22	60	18	10	5.6	—	—	—	23,650	
0770 07322075	-75 -90	1	22	75	60	18	10	5.6	—	—	23,870	M10
0770 07322090		1	22	90	60	18	10	5.6	—	—	24,310	
0770 06323045	-FMH22.225 -47 -45	1	22.225	45	47	17	8	3.5	—	—	23,210	M10
0770 06323060		1	22.225	60	47	17	8	3.5	—	—	23,650	
0770 06323075	-75 -90	1	22.225	75	47	17	8	3.5	—	—	23,870	M10
0770 06323090		1	22.225	90	47	17	8	3.5	—	—	24,310	
0770 07323045	-60 -45	1	22.225	45	60	17	8	3.5	—	—	23,210	M10
0770 07323060		1	22.225	60	60	17	8	3.5	—	—	23,650	
0770 07323075	-75 -90	1	22.225	75	60	17	8	3.5	—	—	23,870	M10
0770 07323090		1	22.225	90	60	17	8	3.5	—	—	24,310	
0770 06325060	-FMH25.4 -60 -60	1	25.4	60	60	22	9.5	5	—	—	23,650	M12
0770 06325075		1	25.4	75	60	22	9.5	5	—	—	23,870	
0770 06325090	-90 -60	1	25.4	90	60	22	9.5	5	—	—	24,310	M12
0770 06327060		1	27	60	60	20	12	6	—	—	23,650	
0770 06327075	-75 -90	1	27	75	60	20	12	6	—	—	23,870	M12
0770 06327090		1	27	90	60	20	12	6	—	—	24,310	
0770 07327060	-76 -60	2	27	60	76	20	12	6	—	—	23,650	M12
0770 07327075		2	27	75	76	20	12	6	—	—	23,870	
0770 07327090	-90 -60	2	27	90	76	20	12	6	—	—	24,310	M12
0770 06331060		2	31.75	60	76	30	12.7	7	—	—	23,870	
0770 06331075	-75 -90	2	31.75	75	76	30	12.7	7	—	—	24,310	M16
0770 06331090		2	31.75	90	76	30	12.7	7	—	—	24,640	
0770 07331060	-96 -60	2	31.75	60	96	30	12.7	7	—	—	34,120	M16
0770 07331075		2	31.75	75	96	30	12.7	7	—	—	34,850	
0770 07331090	-90 -60	2	31.75	90	96	30	12.7	7	—	—	35,600	M16
0770 06332060		2	32	60	96	22	14	7	—	—	34,120	
0770 06332075	-75 -90	2	32	75	96	22	14	7	—	—	34,850	M16
0770 06332090		2	32	90	96	22	14	7	—	—	35,600	

商品コード Code	型式 Model	Type	D1 (h6)	L1	C1	H1	B1	K1	C2	H2	—	締付ボルト Clamp bolt
0770 06516045	BT50 -FMH16	-34 -45	1	16	45	34	17	8	5	—	—	33,470
0770 06516090		-90	1	16	90	34	17	8	5	—	—	33,810
0770 06516150		-150	1	16	150	34	17	8	5	—	—	34,270
0770 06516200		-200	1	16	200	34	17	8	5	—	—	35,650
0770 06516250		-250	1	16	250	34	17	8	5	—	—	65,550
0770 06516300	-300	1	16	300	34	17	8	5	—	—	78,360	
0770 06522045	-FMH22	-47 -45	1	22	45	47	18	10	5.6	—	—	33,470
0770 06522090		-90	1	22	90	47	18	10	5.6	—	—	36,230
0770 06522150		-150	1	22	150	47	18	10	5.6	—	—	38,760
0770 06522200		-200	1	22	200	47	18	10	5.6	—	—	39,100
0770 06522250		-250	1	22	250	47	18	10	5.6	—	—	65,550
0770 06522300	-300	1	22	300	47	18	10	5.6	—	—	78,360	
0770 07522045	-60	-45	1	22	45	60	18	10	5.6	—	—	33,470
0770 07522090		-90	1	22	90	60	18	10	5.6	—	—	36,230
0770 07522150		-150	1	22	150	60	18	10	5.6	—	—	38,760
0770 07522200		-200	1	22	200	60	18	10	5.6	—	—	39,100
0770 07522250		-250	1	22	250	60	18	10	5.6	—	—	65,550
0770 07522300	-300	1	22	300	60	18	10	5.6	—	—	78,360	
0770 06523045	-FMH22.225	-47 -45	1	22.225	45	47	17	8	3.5	—	—	33,470
0770 06523090		-90	1	22.225	90	47	17	8	3.5	—	—	36,230
0770 06523150		-150	1	22.225	150	47	17	8	3.5	—	—	38,760
0770 06523200		-200	1	22.225	200	47	17	8	3.5	—	—	39,220
0770 06523250		-250	1	22.225	250	47	17	8	3.5	—	—	65,550
0770 06523300	-300	1	22.225	300	47	17	8	3.5	—	—	78,360	
0770 07523045	-60	-45	1	22.225	45	60	17	8	3.5	—	—	33,470
0770 07523090		-90	1	22.225	90	60	17	8	3.5	—	—	36,230
0770 07523150		-150	1	22.225	150	60	17	8	3.5	—	—	38,760
0770 07523200		-200	1	22.225	200	60	17	8	3.5	—	—	39,220
0770 07523250		-250	1	22.225	250	60	17	8	3.5	—	—	65,550
0770 07523300	-300	1	22.225	300	60	17	8	3.5	—	—	78,360	
0770 06525045	-FMH25.4	-60 -45	1	25.4	45	60	22	9.5	5	—	—	33,470
0770 06525090		-90	1	25.4	90	60	22	9.5	5	—	—	36,230
0770 06525150		-150	1	25.4	150	60	22	9.5	5	—	—	38,760
0770 06525200		-200	1	25.4	200	60	22	9.5	5	—	—	39,220
0770 06525250		-250	1	25.4	250	60	22	9.5	5	—	—	65,550
0770 06525300	-300	1	25.4	300	60	22	9.5	5	—	—	78,360	
0770 06527045	-FMH27	-60 -45	1	27	45	60	20	12	6	—	—	33,470
0770 06527090		-90	1	27	90	60	20	12	6	—	—	36,230
0770 06527150		-150	1	27	150	60	20	12	6	—	—	38,760
0770 06527200		-200	1	27	200	60	20	12	6	—	—	39,220
0770 06527250		-250	1	27	250	60	20	12	6	—	—	65,550
0770 06527300	-300	1	27	300	60	20	12	6	—	—	78,360	
0770 07527045	-76	-45	1	27	45	76	20	12	6	—	—	33,470
0770 07527090		-90	1	27	90	76	20	12	6	—	—	36,230
0770 07527150		-150	1	27	150	76	20	12	6	—	—	38,760
0770 07527200		-200	1	27	200	76	20	12	6	—	—	39,220
0770 07527250		-250	1	27	250	76	20	12	6	—	—	65,550
0770 07527300	-300	1	27	300	76	20	12	6	—	—	78,360	
0770 06531045	-FMH31.75	-76 -45	1	31.75	45	76	30	12.7	7	—	—	33,470
0770 06531105		-105	1	31.75	105	76	30	12.7	7	—	—	37,950
0770 06531150		-150	1	31.75	150	76	30	12.7	7	—	—	38,760
0770 06531200		-200	1	31.75	200	76	30	12.7	7	—	—	39,220
0770 07531045		-96	-45	1	31.75	45	96	30	12.7	7	—	—
0770 07531105	-105		1	31.75	105	96	30	12.7	7	—	—	37,950
0770 07531150	-150		1	31.75	150	96	30	12.7	7	—	—	38,760
0770 07531200	-200		1	31.75	200	96	30	12.7	7	—	—	39,220
0770 06532045	-FMH32		-96 -45	1	32	45	96	22	14	7	—	—
0770 06532105		-105	1	32	105	96	22	14	7	—	—	37,950
0770 06532150		-150	1	32	150	96	22	14	7	—	—	38,760
0770 06532200		-200	1	32	200	96	22	14	7	—	—	39,220
0770 06538045		-FMH38.1	-80 -45	3	38.1	45	80	34	15.9	9	50	14
0770 06538075	-75		3	38.1	75	80	34	15.9	9	50	14	36,230
0770 06538105	-105		3	38.1	105	80	34	15.9	9	50	14	37,950
0770 06538150	-150		3	38.1	150	80	34	15.9	9	50	14	38,760
0770 07538045	-100		-45	3	38.1	45	100	34	15.9	9	50	14
0770 07538075		-75	3	38.1	75	100	34	15.9	9	50	14	36,230
0770 07538105		-105	3	38.1	105	100	34	15.9	9	50	14	37,950
0770 07538150		-150	3	38.1	150	100	34	15.9	9	50	14	38,760
0770 06540045		-FMH40	-100 -45	3	40	45	100	26	16	8.5	50	14
0770 06540075	-75		3	40	75	100	26	16	8.5	50	14	36,230
0770 06540105	-105		3	40	105	100	26	16	8.5	50	14	37,950
0770 06540150	-150		3	40	150	100	26	16	8.5	50	14	38,760
0770 06550045	-FMH50.8		-100 -45	3	50.8	45	100	36	19.05	10	65	14
0770 06550075		-75	3	50.8	75	100	36	19.05	10	65	14	36,230
0770 06550105		-105	3	50.8	105	100	36	19.05	10	65	14	37,950
0770 06550150		-150	3	50.8	150	100	36	19.05	10	65	14	38,760

締付ボルトは付属しています。
Clamp bolt is Included.

ご注文例 Ordering Example

BT30 - FMH25.4 - 60 - 60

シャンクサイズ
Shank size

インロー径
D1

フランジ径
C1

突き出し長さ(L1)
Projection length

FMH

オイルホール穴付カッター用 フェイスミルアーバ

Face Mill Arbor (For Cutters with Oil Hole)

- ホルダイナーロー端面部からオイルホール穴付カッターへクーラント供給できます。
Coolant flows from the end face of centering location to cutter with oil hole.

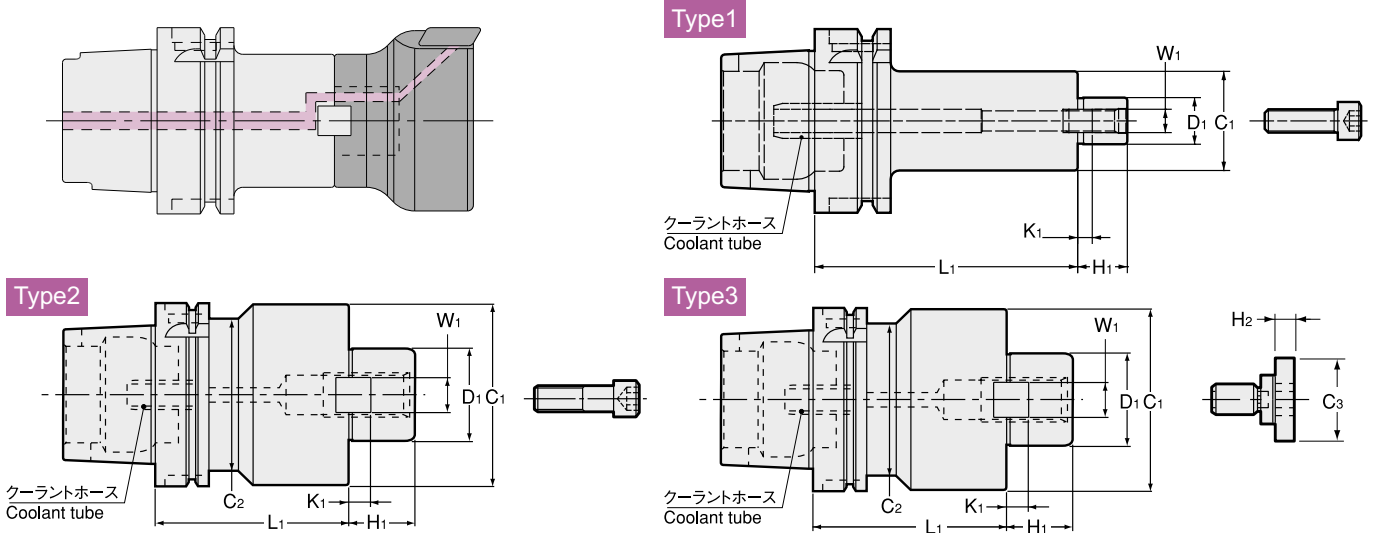

商品コード Code	型式 Model	Type	D1 (h6)	L1	C1	C2	H1	W1	K1	C3	H2	—	締付ボルト Clamp bolt
5340 13616060	HSK40A -FMH16 -34 -60	1	16	60	34	—	17	8	5	—	—	21,700	M8
5340 13622060	-FMH22 -47 -60	2	22	60	47	34	18	10	5.6	—	—	21,700	M10
5340 13623060	-FMH22.225 -47 -60	2	22.225	60	47	34	17	8	3.5	—	—	21,700	M10
5340 13625060	-FMH25.4 -60 -60	2	25.4	60	60	34	22	9.5	5	—	—	21,900	M12
5340 13627060	-FMH27 -60 -60	2	27	60	60	34	20	12	6	—	—	21,900	M12
5340 14616060	HSK50A -FMH16 -34 -60	1	16	60	34	—	17	8	5	—	—	21,700	M8
5340 14622060	-FMH22 -47 -60	2	22	60	47	42	18	10	5.6	—	—	21,700	M10
5340 14623060	-FMH22.225 -47 -60	2	22.225	60	47	42	17	8	3.5	—	—	21,900	M10
5340 14625060	-FMH25.4 -60 -60	2	25.4	60	60	42	22	9.5	5	—	—	21,900	M12
5340 14627060	-FMH27 -60 -60	2	27	60	60	42	20	12	6	—	—	21,900	M12
5340 15616060	HSK63A -FMH16 -34 -60	1	16	60	34	—	17	8	5	—	—	21,700	M8
5340 15616090	-90	1	16	90	34	—	17	8	5	—	—	21,900	M8
5340 15616120	-120	1	16	120	34	—	17	8	5	—	—	22,300	M8
5340 15622060	-FMH22 -47 -60	1	22	60	47	—	18	10	5.6	—	—	26,200	M10
5340 15622090	-90	1	22	90	47	—	18	10	5.6	—	—	26,600	M10
5340 15622120	-120	1	22	120	47	—	18	10	5.6	—	—	26,800	M10
5340 15722060	-60 -60	2	22	60	60	53	18	10	5.6	—	—	26,200	M10
5340 15722090	-90	2	22	90	60	53	18	10	5.6	—	—	26,600	M10
5340 15722120	-120	2	22	120	60	53	18	10	5.6	—	—	26,800	M10
5340 15623060	-FMH22.225 -47 -60	1	22.225	60	47	—	17	8	3.5	—	—	26,200	M10
5340 15623090	-90	1	22.225	90	47	—	17	8	3.5	—	—	26,600	M10
5340 15623120	-120	1	22.225	120	47	—	17	8	3.5	—	—	26,800	M10
5340 15723060	-60 -60	2	22.225	60	60	53	17	8	3.5	—	—	26,200	M10
5340 15723090	-90	2	22.225	90	60	53	17	8	3.5	—	—	26,600	M10
5340 15723120	-120	2	22.225	120	60	53	17	8	3.5	—	—	26,800	M10
5340 15625060	-FMH25.4 -60 -60	2	25.4	60	60	53	22	9.5	5	—	—	26,800	M12
5340 15625090	-90	2	25.4	90	60	53	22	9.5	5	—	—	27,000	M12
5340 15625120	-120	2	25.4	120	60	53	22	9.5	5	—	—	27,400	M12
5340 15627060	-FMH27 -60 -60	2	27	60	60	53	20	12	6	—	—	26,800	M12
5340 15627090	-90	2	27	90	60	53	20	12	6	—	—	27,000	M12
5340 15627120	-120	2	27	120	60	53	20	12	6	—	—	27,400	M12
5340 15727060	-76 -60	2	27	60	76	53	20	12	6	—	—	26,800	M12
5340 15727090	-90	2	27	90	76	53	20	12	6	—	—	27,000	M12
5340 15727120	-120	2	27	120	76	53	20	12	6	—	—	27,400	M12
5340 15631060	-FMH31.75 -76 -60	2	31.75	60	76	53	30	12.7	7	—	—	26,800	M16
5340 15631090	-90	2	31.75	90	76	53	30	12.7	7	—	—	27,000	M16
5340 15631120	-120	2	31.75	120	76	53	30	12.7	7	—	—	27,400	M16
5340 15731060	-96 -60	2	31.75	60	96	53	30	12.7	7	—	—	26,800	M16
5340 15731090	-90	2	31.75	90	96	53	30	12.7	7	—	—	27,000	M16
5340 15731120	-120	2	31.75	120	96	53	30	12.7	7	—	—	27,400	M16
5340 15632060	-FMH32 -96 -60	2	32	60	96	53	22	14	7	—	—	29,400	M16
5340 15632090	-90	2	32	90	96	53	22	14	7	—	—	29,700	M16
5340 15632120	-120	2	32	120	96	53	22	14	7	—	—	30,100	M16

商品コード Code	型式 Model	Type	D1 (h6)	L1	C1	C2	H1	W1	K1	C3	H2	—	締付ボルト Clamp bolt		
5340 17616075	HSK100A -FMH16	-34	-75	1	16	75	34	—	17	8	5	—	—	36,400	
5340 17616105			-105	1	16	105	34	—	17	8	5	—	—	36,700	
5340 17616135			-135	1	16	135	34	—	17	8	5	—	—	37,200	
5340 17616150			-150	1	16	150	34	—	17	8	5	—	—	39,200	
5340 17616200			-200	1	16	200	34	—	17	8	5	—	—	45,200	
5340 17616250			-250	1	16	250	34	—	17	8	5	—	—	51,400	
5340 17622075	-FMH22	-47	-75	1	22	75	47	—	18	10	5.6	—	—	37,200	
5340 17622105			-105	1	22	105	47	—	18	10	5.6	—	—	37,600	
5340 17622135			-135	1	22	135	47	—	18	10	5.6	—	—	38,000	
5340 17622150			-150	1	22	150	47	—	18	10	5.6	—	—	40,100	
5340 17622200			-200	1	22	200	47	—	18	10	5.6	—	—	46,200	
5340 17622250			-250	1	22	250	47	—	18	10	5.6	—	—	52,500	
5340 17722075	-60	-75	-75	1	22	75	60	—	18	10	5.6	—	—	37,200	
5340 17722105			-105	1	22	105	60	—	18	10	5.6	—	—	37,600	
5340 17722135			-135	1	22	135	60	—	18	10	5.6	—	—	38,000	
5340 17722150			-150	1	22	150	60	—	18	10	5.6	—	—	40,100	
5340 17722200			-200	1	22	200	60	—	18	10	5.6	—	—	46,200	
5340 17722250			-250	1	22	250	60	—	18	10	5.6	—	—	52,500	
5340 17623075	-FMH22.225	-47	-75	1	22.225	75	47	—	17	8	3.5	—	—	37,200	
5340 17623105			-105	1	22.225	105	47	—	17	8	3.5	—	—	37,600	
5340 17623135			-135	1	22.225	135	47	—	17	8	3.5	—	—	38,000	
5340 17623150			-150	1	22.225	150	47	—	17	8	3.5	—	—	40,100	
5340 17623200			-200	1	22.225	200	47	—	17	8	3.5	—	—	46,200	
5340 17623250			-250	1	22.225	250	47	—	17	8	3.5	—	—	52,500	
5340 17723075	-60	-75	-75	1	22.225	75	60	—	17	8	3.5	—	—	37,200	
5340 17723105			-105	1	22.225	105	60	—	17	8	3.5	—	—	37,600	
5340 17723135			-135	1	22.225	135	60	—	17	8	3.5	—	—	38,000	
5340 17723150			-150	1	22.225	150	60	—	17	8	3.5	—	—	40,100	
5340 17723200			-200	1	22.225	200	60	—	17	8	3.5	—	—	46,200	
5340 17723250			-250	1	22.225	250	60	—	17	8	3.5	—	—	52,500	
5340 17625075	-FMH25.4	-60	-75	1	25.4	75	60	—	22	9.5	5	—	—	37,200	
5340 17625105			-105	1	25.4	105	60	—	22	9.5	5	—	—	37,600	
5340 17625135			-135	1	25.4	135	60	—	22	9.5	5	—	—	38,000	
5340 17625150			-150	1	25.4	150	60	—	22	9.5	5	—	—	42,100	
5340 17625200			-200	1	25.4	200	60	—	22	9.5	5	—	—	48,500	
5340 17627075		-FMH27	-60	-75	1	27	75	60	—	20	12	6	—	—	37,200
5340 17627105			-105	1	27	105	60	—	20	12	6	—	—	37,600	
5340 17627135			-135	1	27	135	60	—	20	12	6	—	—	38,000	
5340 17627150			-150	1	27	150	60	—	20	12	6	—	—	42,100	
5340 17627200			-200	1	27	200	60	—	20	12	6	—	—	48,500	
5340 17727075	-76		-75	-75	1	27	75	76	—	20	12	6	—	—	37,200
5340 17727105			-105	1	27	105	76	—	20	12	6	—	—	37,600	
5340 17727135			-135	1	27	135	76	—	20	12	6	—	—	38,000	
5340 17727150			-150	1	27	150	76	—	20	12	6	—	—	42,100	
5340 17727200			-200	1	27	200	76	—	20	12	6	—	—	48,500	
5340 17631075		-FMH31.75	-76	-75	1	31.75	75	76	—	30	12.7	7	—	—	37,200
5340 17631105			-105	1	31.75	105	76	—	30	12.7	7	—	—	37,600	
5340 17631135			-135	1	31.75	135	76	—	30	12.7	7	—	—	38,000	
5340 17631150			-150	1	31.75	150	76	—	30	12.7	7	—	—	45,600	
5340 17631200			-200	1	31.75	200	76	—	30	12.7	7	—	—	51,600	
5340 17731075	-96		-75	-75	2	31.75	75	96	85	30	12.7	7	—	—	37,200
5340 17731105			-105	2	31.75	105	96	85	30	12.7	7	—	—	37,600	
5340 17731135			-135	2	31.75	135	96	85	30	12.7	7	—	—	38,000	
5340 17731150			-150	2	31.75	150	96	85	30	12.7	7	—	—	45,600	
5340 17731200			-200	2	31.75	200	96	85	30	12.7	7	—	—	51,600	
5340 17632075		-FMH32	-96	-75	2	32	75	96	85	22	14	7	—	—	37,200
5340 17632105			-105	2	32	105	96	85	22	14	7	—	—	37,600	
5340 17632135			-135	2	32	135	96	85	22	14	7	—	—	38,000	
5340 17638075	-FMH38.1		-80	-75	3	38.1	75	80	80	34	15.9	9	50	14	37,200
5340 17638105				-105	3	38.1	105	80	80	34	15.9	9	50	14	37,600
5340 17638135				-135	3	38.1	135	80	80	34	15.9	9	50	14	38,000
5340 17738075		-100	-75	-75	3	38.1	75	100	85	34	15.9	9	50	14	37,200
5340 17738105				-105	3	38.1	105	100	85	34	15.9	9	50	14	37,600
5340 17738135				-135	3	38.1	135	100	85	34	15.9	9	50	14	38,000
5340 17640075	-FMH40		-100	-75	3	40	75	100	85	26	16	8.5	50	14	37,200
5340 17640105				-105	3	40	105	100	85	26	16	8.5	50	14	37,600
5340 17640135				-135	3	40	135	100	85	26	16	8.5	50	14	38,000
5340 17650075		-FMH50.8	-100	-75	3	50.8	75	100	85	36	19.05	10	65	14	37,200
5340 17650105				-105	3	50.8	105	100	85	36	19.05	10	65	14	37,600
5340 17650135				-135	3	50.8	135	100	85	36	19.05	10	65	14	38,000

締付ボルトは付属しています。
Clamp bolt is Included.

ご注文例 Ordering Example

HSK63A - FMH25.4 - 60 - 60
 シャンクサイズ インロー径 フランジ径 突き出し長さ(L1)
 Shank size D1 C1 Projection length

特殊品もご用命ください。



Specials on request

FMH

オイルホール穴付カッター用 フェイスミルアーバ

Face Mill Arbor (For Cutters with Oil Hole)

- ホルダインロー端面部からオイルホール穴付カッターへクーラント供給できます。
Coolant flows from the end face of centering location to cutter with oil hole.

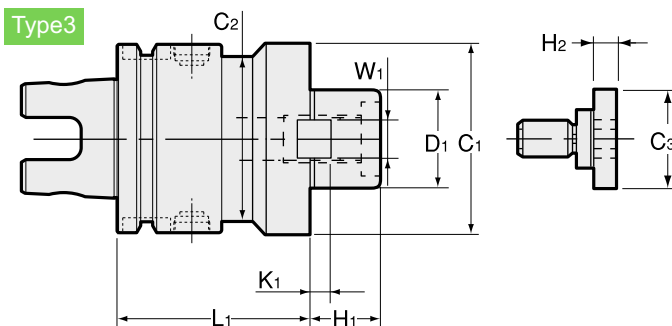
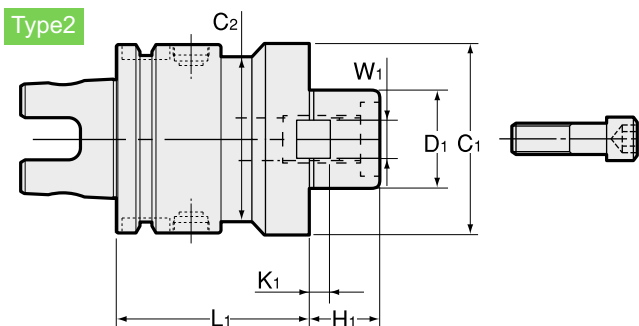
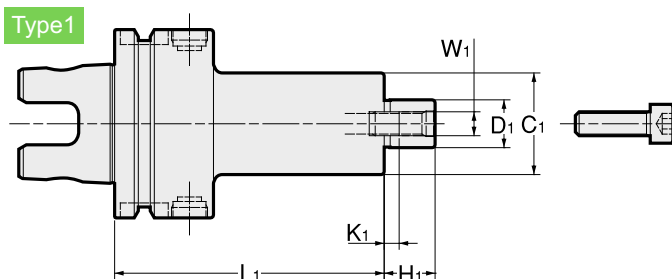
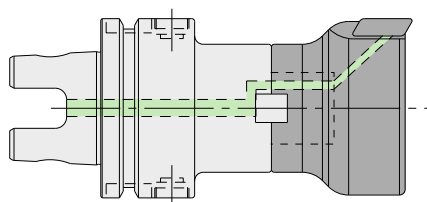

商品コード Code	型式 Model	Type	D1 (h6)	L1	C1	C2	H1	W1	K1	C3	H2	—	締付ボルト Clamp bolt
1320 21116060	UTS5040 -FMH16 -34 -60-H	1	16	60	34	—	17	8	5	—	—	26,730	M8
1320 21122060	-FMH22 -47 -60-H	1	22	60	47	—	18	10	5.6	—	—	26,730	M10
1320 21123060	-FMH22.225 -47 -60-H	1	22.225	60	47	—	17	8	3.5	—	—	26,730	M10
1320 21125060	-FMH25.4 -60 -60-H	2	25.4	60	60	50	22	9.5	5	—	—	26,950	M12
1320 21127060	-FMH27 -60 -60-H	2	27	60	60	50	20	12	6	—	—	26,950	M12
1320 2*216060	UTS6350 -FMH16 -34 -60	1	16	60	34	—	17	8	5	—	—	26,730	M8
1320 2*216090	-90	1	16	90	34	—	17	8	5	—	—	26,730	M8
1320 2*216120	-120	1	16	120	34	—	17	8	5	—	—	26,950	M8
1320 2*222060	-FMH22 -47 -60	1	22	60	47	—	18	10	5.6	—	—	26,730	M10
1320 2*222090	-90	1	22	90	47	—	18	10	5.6	—	—	26,950	M10
1320 2*222120	-120	1	22	120	47	—	18	10	5.6	—	—	27,390	M10
1320 3*222060	-60 -60	1	22	60	60	—	18	10	5.6	—	—	26,730	M10
1320 3*222090	-90	1	22	90	60	—	18	10	5.6	—	—	26,950	M10
1320 3*222120	-120	1	22	120	60	—	18	10	5.6	—	—	27,390	M10
1320 2*223060	-FMH22.225 -47 -60	1	22.225	60	47	—	17	8	3.5	—	—	26,730	M10
1320 2*223090	-90	1	22.225	90	47	—	17	8	3.5	—	—	26,950	M10
1320 2*223120	-120	1	22.225	120	47	—	17	8	3.5	—	—	27,390	M10
1320 3*223060	-60 -60	1	22.225	60	60	—	17	8	3.5	—	—	26,730	M10
1320 3*223090	-90	1	22.225	90	60	—	17	8	3.5	—	—	26,950	M10
1320 3*223120	-120	1	22.225	120	60	—	17	8	3.5	—	—	27,390	M10
1320 2*225060	-FMH25.4 -60 -60	1	25.4	60	60	—	22	9.5	5	—	—	32,230	M12
1320 2*225090	-90	1	25.4	90	60	—	22	9.5	5	—	—	32,670	M12
1320 2*225120	-120	1	25.4	120	60	—	22	9.5	5	—	—	32,670	M12
1320 2*227060	-FMH27 -60 -60	1	27	60	60	—	20	12	6	—	—	32,230	M12
1320 2*227090	-90	1	27	90	60	—	20	12	6	—	—	32,670	M12
1320 2*227120	-120	1	27	120	60	—	20	12	6	—	—	32,670	M12
1320 3*227060	-76 -60	2	27	60	76	63	20	12	6	—	—	32,230	M12
1320 3*227090	-90	2	27	90	76	63	20	12	6	—	—	32,670	M12
1320 3*227120	-120	2	27	120	76	63	20	12	6	—	—	32,670	M12
1320 2*231060	-FMH31.75 -76 -60	2	31.75	60	76	63	30	12.7	7	—	—	32,230	M16
1320 2*231090	-90	2	31.75	90	76	63	30	12.7	7	—	—	32,670	M16
1320 2*231120	-120	2	31.75	120	76	63	30	12.7	7	—	—	32,670	M16
1320 3*231060	-96 -60	2	31.75	60	96	63	30	12.7	7	—	—	32,230	M16
1320 3*231090	-90	2	31.75	90	96	63	30	12.7	7	—	—	32,670	M16
1320 3*231120	-120	2	31.75	120	96	63	30	12.7	7	—	—	32,670	M16
1320 2*232060	-FMH32 -96 -60	2	32	60	96	63	22	14	7	—	—	32,230	M16
1320 2*232090	-90	2	32	90	96	63	22	14	7	—	—	32,670	M16
1320 2*232120	-120	2	32	120	96	63	22	14	7	—	—	32,670	M16

商品コード Code	型式 Model	Type	D1 (h6)	L1	C1	C2	H1	W1	K1	C3	H2	—	締付ボルト Clamp bolt		
1320 2※316075	UTS10080 -FMH16	-34	-75	1	16	75	34	—	17	8	5	—	44,770	M8	
1320 2※316105			-105	1	16	105	34	—	17	8	5	—	45,100		
1320 2※316135			-135	1	16	135	34	—	17	8	5	—	45,760		
1320 2※322075	-FMH22	-47	-75	1	22	75	47	—	18	10	5.6	—	45,760	M10	
1320 2※322105			-105	1	22	105	47	—	18	10	5.6	—	46,200		
1320 2※322135			-135	1	22	135	47	—	18	10	5.6	—	46,750		
1320 3※322075		-60	-75	1	22	75	60	—	18	10	5.6	—	45,760	M10	
1320 3※322105		-105	1	22	105	60	—	18	10	5.6	—	46,200			
1320 3※322135		-135	1	22	135	60	—	18	10	5.6	—	46,750			
1320 2※323075	-FMH22.225	-47	-75	1	22.225	75	47	—	17	8	3.5	—	45,760	M10	
1320 2※323105			-105	1	22.225	105	47	—	17	8	3.5	—	46,200		
1320 2※323135			-135	1	22.225	135	47	—	17	8	3.5	—	46,750		
1320 3※323075		-60	-75	1	22.225	75	60	—	17	8	3.5	—	45,760	M10	
1320 3※323105		-105	1	22.225	105	60	—	17	8	3.5	—	46,200			
1320 3※323135		-135	1	22.225	135	60	—	17	8	3.5	—	46,750			
1320 2※325075	-FMH25.4	-60	-75	1	25.4	75	60	—	22	9.5	5	—	45,760	M12	
1320 2※325105			-105	1	25.4	105	60	—	22	9.5	5	—	46,200		
1320 2※325135			-135	1	25.4	135	60	—	22	9.5	5	—	46,750		
1320 2※327075	-FMH27	-60	-75	1	27	75	60	—	20	12	6	—	45,760	M12	
1320 2※327105			-105	1	27	105	60	—	20	12	6	—	46,200		
1320 2※327135			-135	1	27	135	60	—	20	12	6	—	46,750		
1320 3※327075		-76	-75	1	27	75	76	—	20	12	6	—	45,760	M12	
1320 3※327105		-105	1	27	105	76	—	20	12	6	—	46,200			
1320 3※327135		-135	1	27	135	76	—	20	12	6	—	46,750			
1320 2※331075	-FMH31.75	-76	-75	1	31.75	75	76	—	30	12.7	7	—	45,760	M16	
1320 2※331105			-105	1	31.75	105	76	—	30	12.7	7	—	46,200		
1320 2※331135			-135	1	31.75	135	76	—	30	12.7	7	—	46,750		
1320 3※331075		-96	-75	1	31.75	75	96	—	30	12.7	7	—	45,760	M16	
1320 3※331105		-105	1	31.75	105	96	—	30	12.7	7	—	46,200			
1320 3※331135		-135	1	31.75	135	96	—	30	12.7	7	—	46,750			
1320 2※332075	-FMH32	-96	-75	1	32	75	96	—	22	14	7	—	45,760	M16	
1320 2※332105			-105	1	32	105	96	—	22	14	7	—	46,200		
1320 2※332135			-135	1	32	135	96	—	22	14	7	—	46,750		
1320 2※338075	-FMH38.1	-80	-75	3	38.1	75	80	80	34	15.9	9	50	14	45,760	MBAH-M20
1320 2※338105			-105	3	38.1	105	80	80	34	15.9	9	50	14	46,200	
1320 2※338135			-135	3	38.1	135	80	80	34	15.9	9	50	14	46,750	
1320 3※338075		-100	-75	3	38.1	75	100	100	34	15.9	9	50	14	45,760	MBAH-M20
1320 3※338105		-105	3	38.1	105	100	100	34	15.9	9	50	14	46,200		
1320 3※338135		-135	3	38.1	135	100	100	34	15.9	9	50	14	46,750		
1320 2※340075	-FMH40	-100	-75	3	40	75	100	100	26	16	8.5	50	14	45,760	MBAH-M20
1320 2※340105			-105	3	40	105	100	100	26	16	8.5	50	14	46,200	
1320 2※340135			-135	3	40	135	100	100	26	16	8.5	50	14	46,750	
1320 2※350075	-FMH50.8	-100	-75	3	50.8	75	100	100	36	19.05	10	65	14	45,760	MBAH-M24
1320 2※350105			-105	3	50.8	105	100	100	36	19.05	10	65	14	46,200	
1320 2※350135			-135	3	50.8	135	100	100	36	19.05	10	65	14	46,750	

商品コードの※は低圧用では0、高圧用では1となります。

- 締付ボルトは付属しています。
 - UTS5040 は高圧用のみになります。
- Clamp bolt is Included.
 - Only high pressure type is available for UTS5040.

ご注文例 Ordering Example

低圧用 Low pressure type

0 ~ 1.0MPa (UTS10080 のみ 0 ~ 2.0MPa)

UTS6350 - FMH25.4 - 60 - 60

シャングサイズ インロー径 フランジ径 突き出し長さ(L1)

Shank size D1 C1 Projection length

ご注文例 Ordering Example

高圧用 High pressure type

1.1 ~ 7.0MPa (UTS10080 のみ 2.1 ~ 7.0MPa)

UTS6350 - FMH25.4 - 60 - 60 - H

シャングサイズ インロー径 フランジ径 突き出し長さ(L1) 高圧の場合

Shank size D1 C1 Projection length High pressure type