

SLA

Side Lock Holder

- For straight shank boring bar with flat and straight shank boring head with flat.

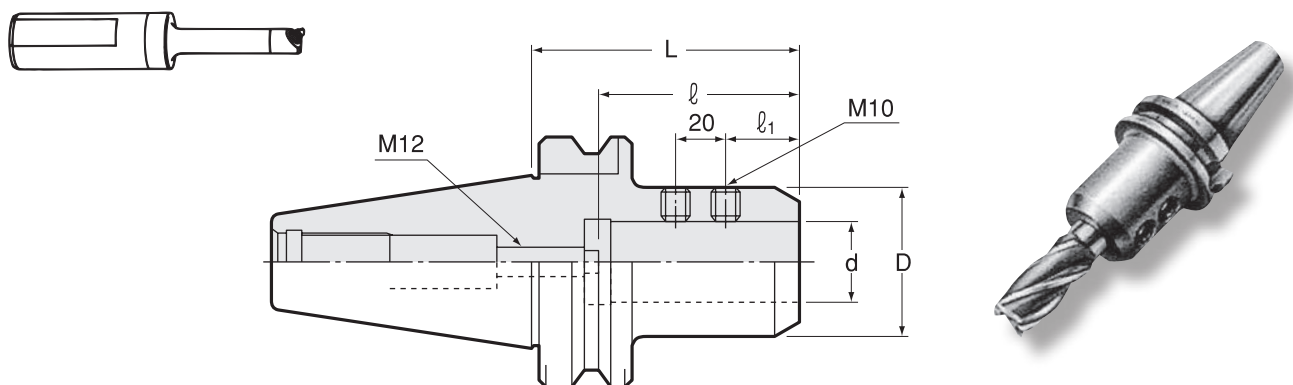

Metric Sizes

Unit : Metric

Code	Model	d (H6)	L	D	l MIN	l MAX	l1	kg
0740 00116075	BT30 -SLA16 -75	16	75	40	55	70	25	0.8
0740 00120075	BT30 -SLA20 -75	20	75	40	55	70	25	0.8
0740 00125075	BT30 -SLA25 -75	25	75	46	55	70	25	0.8
0740 00320090	BT40 -SLA20 -90	20	90	50	55	70	25	1.8
0740 00325090	BT40 -SLA25 -90	25	90	50	55	70	25	1.7
0740 00332090	BT40 -SLA32 -90	32	90	60	65	80	30	1.9
0740 00342090	BT40 -SLA42 -90	42	90	63	65	80	30	1.6
0740 00520105	BT50 -SLA20 -105	20	105	50	55	70	25	4.4
0740 00525105	BT50 -SLA25 -105	25	105	50	55	70	25	4.3
0740 00532105	BT50 -SLA32 -105	32	105	60	65	80	30	4.5
0740 00542105	BT50 -SLA42 -105	42	105	70	65	80	30	4.7

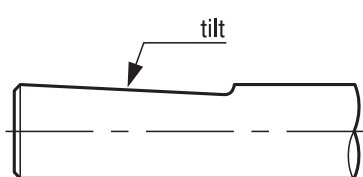

Please contact NT if the cutting tool has tilted flat on the shank.
Special tool holder that matches to the tilted flat can be manufactured.

Ordering Example

BT30 - SLA 16 - 75
 Shank size I.D. (d) Projection length (L)

SLA

Side Lock Holder

- For straight shank boring bar with flat and straight shank boring head with flat.

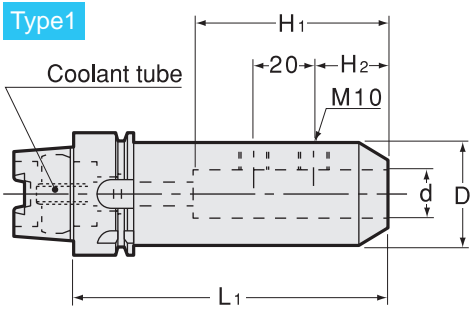

● Coolant tube is included.

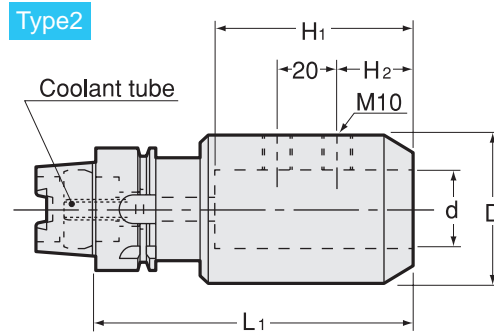

● Coolant tube is included.

Metric Sizes

Unit : Metric

Code	Model	Type	d	L1	D	H1	H2	kg
5420 13116090	HSK40A -SLA16 -90	2	16	90	40	65	25	
5420 13120090	HSK40A -SLA20 -90	2	20	90	40	65	25	
5420 13125105	HSK40A -SLA25 -105	2	25	105	46	65	25	0.9
5420 14116090	HSK50A -SLA16 -90	1	16	90	40	65	25	
5420 14120090	HSK50A -SLA20 -90	1	20	90	40	65	25	0.9
5420 14125105	HSK50A -SLA25 -105	2	25	105	46	65	25	1.1
5420 15120090	HSK63A -SLA20 -90	1	20	90	50	65	25	1.5
5420 15125105	HSK63A -SLA25 -105	1	25	105	50	65	25	1.6
5420 15132105	HSK63A -SLA32 -105	2	32	105	60	75	30	1.8
5420 17120105	HSK100A -SLA20 -105	1	20	105	50	65	25	3.0
5420 17125105	HSK100A -SLA25 -105	1	25	105	50	65	25	2.9
5420 17132120	HSK100A -SLA32 -120	1	32	120	60	75	30	3.6
5420 17142120	HSK100A -SLA42 -120	1	42	120	70	75	30	3.9

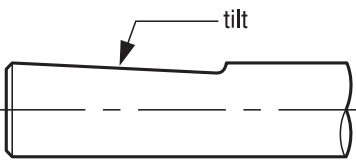

Please contact NT if the cutting tool has tilted flat on the shank.
Special tool holder that matches to the tilted flat can be manufactured.

Ordering Example

HSK40A - SLA - 20 - 90
 Shank size I.D. (d) Projection length (L)