

TP3B

Quick Change Tapping Chuck (Auto Depth Control)

- Auto depth control mechanism stabilizes tapping depth.

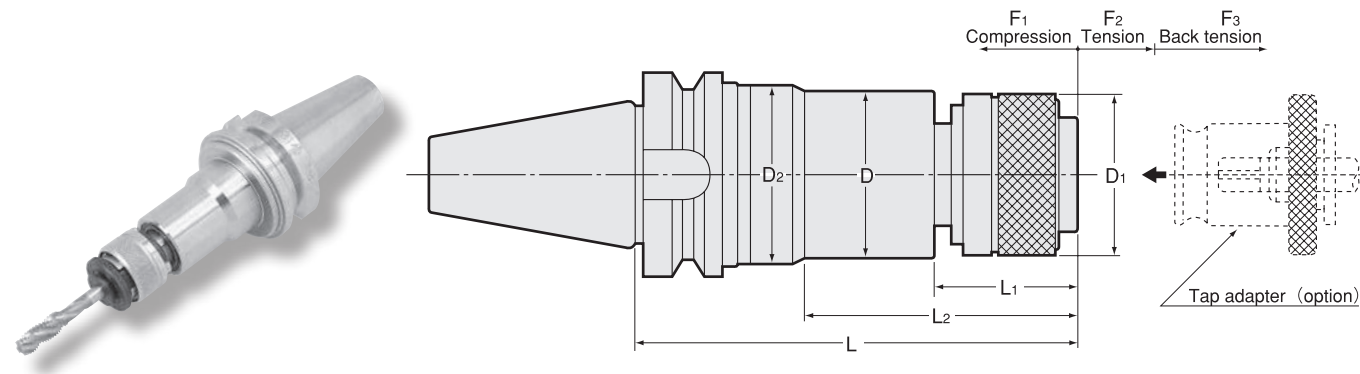

 For Inch size tap, please refer to P.463.

Metric Sizes

Unit : Metric

Code	Model	Tap Size	Adapter size	L	L1	L2	D	D1	D2	Axial compensation			kg
										F1	F2	F3	
3000 10001113	BT30 -TP3B-1 -113	M3 ~ M12 (M15), U1/4 ~ U7/16 (U9/16), Pipe(PT,PS,PF)1/8 ~ 1/4	1	113	30	61.5	34	32	39	0.5	4	8	0.8
3000 30001113	BT40 -TP3B-1 -113	M3 ~ M12 (M15), U1/4 ~ U7/16 (U9/16), Pipe(PT,PS,PF)1/8 ~ 1/4	1	113	30	61.5	34	32	39	0.5	4	8	1.4
3000 30002135	BT40 -TP3B-2 -135	M8 ~ M22, U3/8 ~ U7/8, Pipe(PT,PS,PF)1/8 ~ 1/2	2	135	44.5	86.5	52	50	56	0.5	5	11	2.1
3000 50001128	BT50 -TP3B-1 -128	M3 ~ M12 (M15), U1/4 ~ U7/16 (U9/16), Pipe(PT,PS,PF)1/8 ~ 1/4	1	128	30	61.5	34	32	39	0.5	4	8	4.1
3000 50002150	BT50 -TP3B-2 -150	M8 ~ M22, U3/8 ~ U7/8, Pipe(PT,PS,PF)1/8 ~ 1/2	2	150	44.5	86.5	52	50	56	0.5	5	11	4.7
3000 50003181	BT50 -TP3B-3 -181	M16 ~ M38, U5/8 ~ U1,3/8, Pipe(PT,PS,PF)1/4 ~ 1 1/8	3	181	65.5	119	76	72	80	0.5	6	12	6.4

1. Tap sizes in brackets are for light tapping only.
2. Tap adapter with safety torque clutch cannot be used.
3. Tap adapter is sold separately.

Tap adapter

P. 458

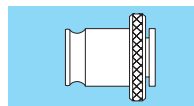

Ordering Example

BT40 - TP3B-1 - 113

Shank size Adapter size Projection length(L)