

STP

Synchro Tapping Chuck

- Quick-changeable tap adapter.

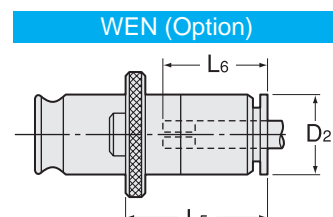
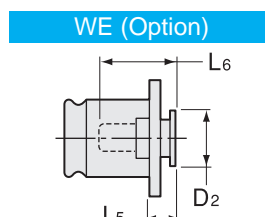
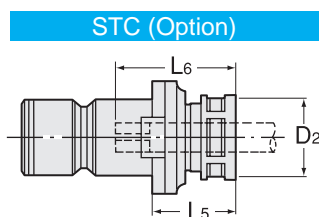
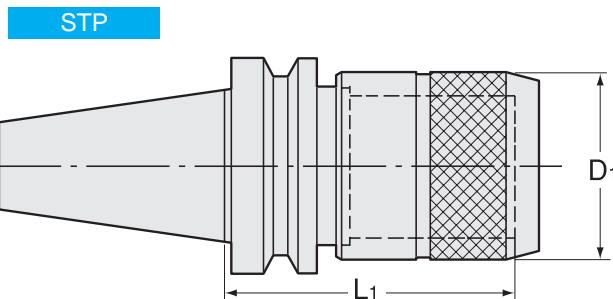

For Inch size tap, please refer to P. 463.

Unit : Metric

Code	Model	L1	D1	kg	Tap adapter	L5	D2	Tap Size			
								Metric thread	OSG synchro tap	Pipetap	ANSI
2780 01001065	BT30 -STP1 -65	65	38	0.6	STC1- ※※※	26	26	M3 ~ M12	M3 ~ M10	PIPE (PT,PS,PF) 1/8	#8-12, 1/4, 5/16, 7/16, 1/8SS
					WEN1B- ※※※	33	19				
					WE1- ※※※	7	19				
2780 03001065	BT40 -STP1 -65	65	38	1.2	STC1- ※※※	26	26	M3 ~ M12	M3 ~ M10	PIPE (PT,PS,PF) 1/8	#8-12, 1/4, 5/16, 7/16, 1/8SS
					WEN1B- ※※※	33	19				
					WE1- ※※※	7	19				
2780 03001095	-95	95	38	1.4	WE1- ※※※	7	19				
2780 03002085	BT40 -STP2 -85	85	55	1.5	STC2- ※※※	35	36	M8 ~ M20	M8 ~ M14	PIPE (PT,PS,PF) 1/8 PIPE (PT,PS,PF) 1/4 PIPE (PT,PS,PF) 3/8	1/4-3/4, 1/8SS, 1/8SL, 1/4P
					WEN2B- ※※※	59	30				
					WE2- ※※※	11	30				
2780 05001080	BT50 -STP1 -80	80	38	3.8	STC1- ※※※	26	26	M3 ~ M12	M3 ~ M10	PIPE (PT,PS,PF) 1/8	#8-12, 1/4, 5/16, 7/16, 1/8SS
					WEN1B- ※※※	33	19				
					WE1- ※※※	7	19				
2780 05001110	-110	110	38	4.2	WE1- ※※※	7	19				
2780 05002100	BT50 -STP2 -100	100	55	4.2	STC2- ※※※	35	36	M8 ~ M20	M8 ~ M14	PIPE (PT,PS,PF) 1/8 PIPE (PT,PS,PF) 1/4 PIPE (PT,PS,PF) 3/8	1/4-3/4, 1/8SS, 1/8SL, 1/4P
					WEN2B- ※※※	59	30				
					WE2- ※※※	11	30				
2780 05002130	-130	130	55	4.8	WE2- ※※※	11	30				

L5 values are in the case of metric thread.

STC L6 Dimension

Please refer to P. 458 for L6 dimension of WE.
Please refer to P. 460 for L6 dimension of WEN.

Unit : Metric

STC1 L6	M3	M4	M5	M6	M8	M10	M11	M12	Pipe1/8
MIN	24	26	31	31	32	32	32	33	34
MAX	29	31	35	35	37	37	37	37	38

Unit : Metric

STC2 L6	M8	M10	M11	M12	M14	M16	M17	M18	M20	Pipe1/8	Pipe1/4	Pipe3/8
MIN	34	34	33	35	39	41	41	43	43	29	29	33
MAX	39	39	38	40	44	46	46	48	48	33	31	34

Code	Model	Collet			Nut	Spanner
		Metric thread	Pipe tap	OSG synchro tap		
2800 00001 ※※※	STC1- ※※※	FDC-09		FDC-09	HDP-09B	S-1L
2800 00001 ※※※	STC1- ※※※		ESC10		KDP-1916	S-1L
2800 00002 ※※※	STC2- ※※※	FDC-16		FDC-16	HDP-16B	S-4L
2800 00002 ※※※	STC2- ※※※		ESC16		KDP-2825	S-4L

1. Tap size will be inserted in " ※※※ ".
2. STC adapter comes complete with collet and nut, but spanner is sold separately.
3. When using OSG synchro tap, please specify it.
Example : STC1-M3-O
4. With FDC-OH or C collet (p.087-088) and STC Adapter, STP can be used for center-thru coolant.

STP Holder

Ordering Example

BT40 - STP1 - 95
Shank size Adapter size L1

STC adapter

Ordering Example

STC1 - M10
Size Tap size

WEN-B BILZ Tap Adapter

Ordering Example

WEN1B - M10
Size Tap size

Tap adapter WE
P.458

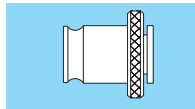

Tap adapter WEN
P.460

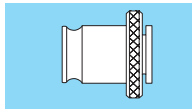

Spanner
P.095



STP

Synchro Tapping Chuck

- Quick-changeable tap adapter.
- For machines with rigid tapping cycles.
- Compatible with NT high precision FDC collets or Bilz (WE/WEN) quick change.
- Length adjustable adapters offer quick easy adjustments.
- Coolant-thru capable with the use of FDC-OH high precision coolant collets. (When STC1 is used)

STP

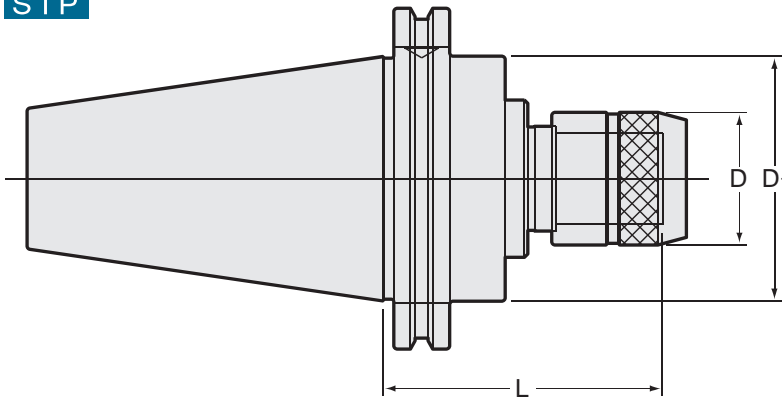

STC

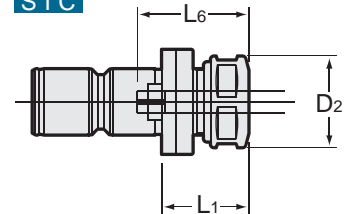
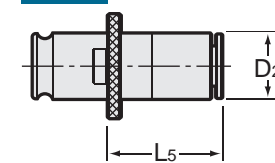
WEN
or WE

Unit : Inch

Code	Model	L	D	D1	kg	Adapter Size	L5	D2	Tapping Capacity	Coolant Pressure
1950 00401075	CAT40 -STP1 -75	2.953	1.496	1.750	1.2	STC1- ***	1.024	1.024	M3 - M12 PT1/8	145psi (1MPa)
1950 00401095	-STP1 -95	3.740	1.496	1.750	1.4	WEN1B- ***	1.299	0.748	#8-12, 1/4, 5/16, 7/16, 1/8SS	
					WE1- ***	0.276	0.748			
1950 00402095	CAT40 -STP2 -95	3.740	2.165	1.850	1.6	STC2- ***	1.378	1.417		
1950 00402115	-STP2 -115	4.528	2.165	1.750	1.9	WEN2B- ***	2.323	1.181	M8 - M20 PT1/8,PT1/4,PT3/8	72.5psi (0.5MPa)
						WE2- ***	0.433	1.181	1/4-3/4, 1/8SS, 1/8LS, 1/4P	
1950 00501110	CAT50 -STP1 -110	4.331	1.496	2.750	3.5	STC1- ***	1.024	1.024	M3 - M12 PT1/8	145psi (1MPa)
						WEN1B- ***	1.299	0.748	#8-12, 1/4, 5/16, 7/16, 1/8SS	
					WE1- ***	0.276	0.748			
1950 00502100	CAT50 -STP2 -100	3.937	2.165	2.750	3.6	STC2- ***	1.378	1.417		
1950 00502130	-STP2 -130	5.118	2.165	2.750	4.2	WEN2B- ***	2.323	1.181	M8 - M20 PT1/8,PT1/4,PT3/8	72.5psi (0.5MPa)
						WE2- ***	0.433	1.181	1/4-3/4, 1/8SS, 1/8LS, 1/4P	

Unit : Inch

L6			L6		
STC1	MIN	MAX	STC2	MIN	MAX
M3	0.945 (1.063)	1.142	M8	1.339 (1.496)	1.535
M4	1.024 (1.102)	1.220	M10	1.339 (1.496)	1.535
M5	1.220	1.378	M11	1.239 (1.496)	1.496
M6	1.220	1.378	M12	1.378 (1.535)	1.575
M8	1.260	1.457	M14	1.535	1.732
M10	1.260	1.457	M16	1.614	1.811
M11	1.260	1.457	M17	1.614	1.811
M12	1.299	1.457	M18	1.693	1.890
PT1/8	1.339	1.496	M20	1.693	1.890
			PT1/8	1.142	1.299
			PT1/4	1.142	1.220
			PT3/8	1.299	1.339

Model	Collet Type		Nut	Spanner
	Metric, Inch Thread	Pipe Tap		
STC1- ***	FDC-09	-	HDP-09B	S-1L
	-	ESC10	KDP-1916	
STC2- ***	FDC-16	-	HDP-16B	S-4L
	-	ESC16	KDP-2825	

STP Holder

Ordering Example

CAT40 - STP1 - 95

Shank size Adapter size L1

STC adapter

Ordering Example

STC1 - M10 - ANSI

Size Tap size ANSI,ISO,DIN,JIS

WEN·B BILZ Tap Adapter

Ordering Example

WEN1B - M10 - ANSI

Size Tap size ANSI,ISO,DIN,JIS

Tap adapter WE

P.458

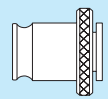

Tap adapter WEN

P.460

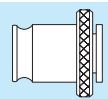

Spanner

P.095



1. STC adapter includes a collet and nut. Spanner is sold separately.
2. When ordering STC Adapter, please specify the tap shank and drive square.
3. With FDC-OH or C collet (p.087-088) and STC Adapter, STP can be used for center-thru coolant.

STP

Synchro Tapping Chuck

- Quick-changeable tap adapter.

STP

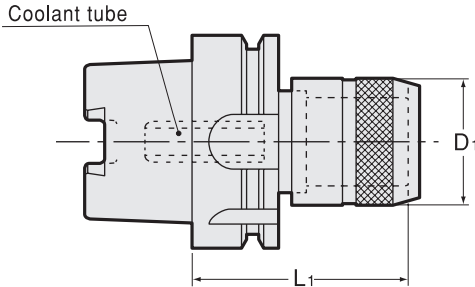

- Coolant tube is included.

For capable tap sizes, please refer to P. 463 chart.

STC (Option)

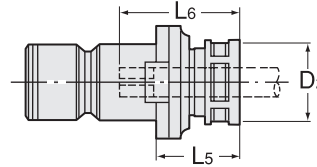

WE (Option)

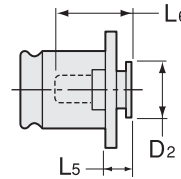

WEN · B (Option)

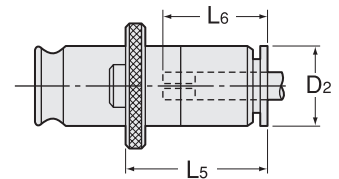

Metric Sizes

Unit : Metric

Code	Model	L1	D1	kg	Tap adapter	L5	D2	Tap Size			
								Metric thread	OSG synchro tap	Pipe tap	ANSI
5520 13001080	HSK40A -STP1 -80	80	38	0.6	STC1- ※※※	26	26	M3 ~ M12	M3 ~ M10	PIPE (PT,PS,PF) 1/8	#8-12, 1/4, 5/16, 7/16, 1/8SS
5520 13001110	-110	110	38	WEN1B- ※※※	33	19					
				WE1- ※※※	7	19					
5520 14001080	HSK50A -STP1 -80	80	38	0.8	STC1- ※※※	26	26	M3 ~ M12	M3 ~ M10	PIPE (PT,PS,PF) 1/8	#8-12, 1/4, 5/16, 7/16, 1/8SS
5520 14001110	-110	110	38	1.1	WEN1B- ※※※	33	19				
				1.1	WE1- ※※※	7	19				
5520 14002100	HSK50A -STP2 -100	100	55	1.2	STC2 - ※※※	35	36	M8 ~ M20	M8 ~ M14	PIPE (PT,PS,PF) 1/8 PIPE (PT,PS,PF) 1/4 PIPE (PT,PS,PF) 3/8	1/4-3/4, 1/8SS, 1/8LS, 1/4P
5520 14002130	-130	130	55	1.5	WEN2B- ※※※	59	30				
				1.5	WE2- ※※※	11	30				
5520 15001080	HSK63A -STP1 -80	80	38	1.0	STC1- ※※※	26	26	M3 ~ M12	M3 ~ M10	PIPE (PT,PS,PF) 1/8	#8-12, 1/4, 5/16, 7/16, 1/8SS
5520 15001110	-110	110	38	1.3	WEN1B- ※※※	33	19				
				1.3	WE1- ※※※	7	19				
5520 15002100	HSK63A -STP2 -100	100	55		STC2 - ※※※	35	36	M8 ~ M20	M8 ~ M14	PIPE (PT,PS,PF) 1/8 PIPE (PT,PS,PF) 1/4 PIPE (PT,PS,PF) 3/8	1/4-3/4, 1/8SS, 1/8LS, 1/4P
5520 15002130	-130	130	55	2.0	WEN2B- ※※※	59	30				
				2.0	WE2- ※※※	11	30				
5520 17001095	HSK100A -STP1 -95	95	38	2.5	STC1- ※※※	26	26	M3 ~ M12	M3 ~ M10	PIPE (PT,PS,PF) 1/8	#8-12, 1/4, 5/16, 7/16, 1/8SS
5520 17001125	-125	125	38		WEN1B- ※※※	33	19				
					WE1- ※※※	7	19				
5520 17002115	HSK100A -STP2 -115	115	55	3.2	STC2 - ※※※	35	36	M8 ~ M20	M8 ~ M14	PIPE (PT,PS,PF) 1/8 PIPE (PT,PS,PF) 1/4 PIPE (PT,PS,PF) 3/8	1/4-3/4, 1/8SS, 1/8LS, 1/4P
5520 17002145	-145	145	55	3.7	WEN2B- ※※※	59	30				
				3.7	WE2- ※※※	11	30				

L5 values are in the case of metric thread.

STC L6 Dimension

Please refer to P. 458, 460 for L6 dimension of WE, WEN · B.

STC1 L6	M3	M4	M5	M6	M8	M10	M11	M12	Pipe1/8
MIN	24	26	31	31	32	32	32	33	34
MAX	29	31	35	35	37	37	37	37	38

STC2 L6	M8	M10	M11	M12	M14	M16	M17	M18	M20	Pipe1/8	Pipe1/4	Pipe3/8
MIN	34	34	33	35	39	41	41	43	43	29	29	33
MAX	39	39	38	40	44	46	46	48	48	33	31	34

Metric Sizes

Unit : Metric

Code	Model	Collet			Nut	Spanner
		Metric thread	Pipe tap	OSG synchro tap		
2800 00001 ※※※	STC1- ※※※	FDC-09		FDC-09	HDP-09B	S-1L
2800 00001 ※※※	STC1- ※※※		ESC10		KDP-1916	S-1L
2800 00002 ※※※	STC2- ※※※	FDC-16		FDC-16	HDP-16B	S-4L
2800 00002 ※※※	STC2- ※※※		ESC16		KDP-2825	S-4L

1. Tap size will be inserted in " ※※※ ".
2. STC adapter comes complete with collet and nut, but spanner is sold separately.
3. When using OSG synchro tap, please specify it.
Example : STC1-M3-O

STP Holder

Ordering Example

HSK40A - STP1 - 80

Shank size Adapter size L1

STC adapter

Ordering Example

STC1 - M10 - ANSI

Size Tap size ANSI,ISO,DIN,JIS

WEN • B BILZ Tap Adapter

Ordering Example

WEN1B - M10 - ANSI

Size Tap size ANSI,ISO,DIN,JIS

BT

CAT

AHO

HSK-A/E/F/C

HSK-T

UTS

Specialized Machine

Related Equipment

Bush & Chamfering Drill

Milling Chuck

Collet Holder

"R" Zero Holder

Hydraulic Chuck

Shrink Fit

Tapping Chuck

Arbors

Function Holder

HSK-E

HSK-F

HSK-C

Tool Shank Dimensions