



For CNC lathe · internal coolant

Coolant Bit Sleeves ST·U-CBS^{PAT.P}



All Coolant Is Supplied To The Cutting Edge Without Loss!

Eliminates coolant leakage problems with conventional tool sleeves and achieves more efficient machining.



Comparison Video



No coolant leaks from the shank flats!

Seal stopper (PAT.P)

Pushed by coolant pressure and adheres to the tool shank end face to prevent coolant leakage from the tool shank flat!

- No decrease in coolant pressure at cutting edge
- Improved surface finish accuracy
- Improved chip removal

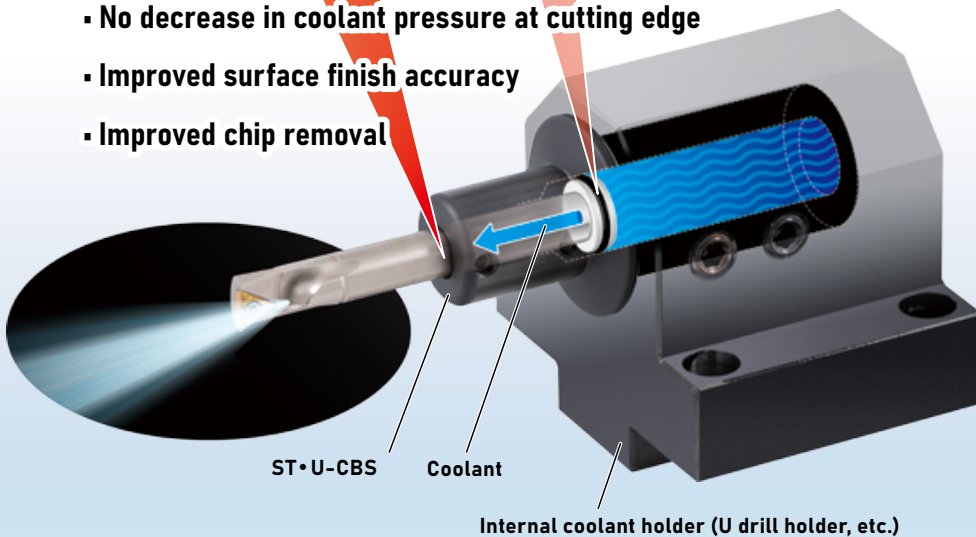

Please contact our sales department if you would like to try out this product!

Coolant Bit Sleeve ST·U-CBS

Type1

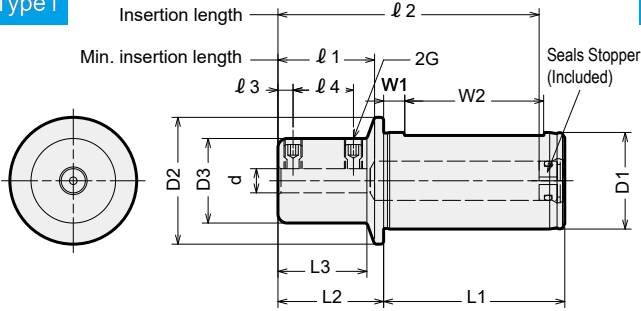

Type2

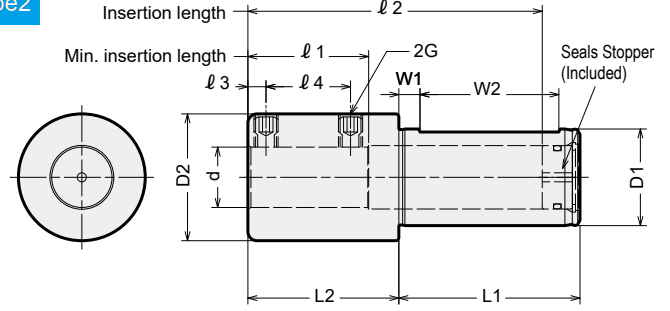

Code	Model	Type	d	D1	D2	D3	L1	L2	L3	l1	l2	l3	l4	W1	W2	G
0490 02508000	ST25U - CBS08	1	8	25	34	28	56	35	30.9	32	82	5	20	7	42	M6
0490 02510000	- CBS10	1	10	25	34	28	56	35	30.9	32	82	5	20	7	42	M6
0490 02512000	- CBS12	1	12	25	34	28	56	35	30.9	36	82	5	20	7	42	M6
0490 02516000	- CBS16	2	16	25	34	—	56	45	—	35	92	5	25	7	42	M6
0490 03208000	ST32U - CBS08	1	8	32	42	28	60	35	29.5	32	86	5	20	7	46	M6
0490 03210000	- CBS10	1	10	32	42	28	60	35	29.5	32	86	5	20	7	46	M6
0490 03212000	- CBS12	1	12	32	42	28	60	35	29.5	36	86	5	20	7	46	M6
0490 03216000	- CBS16	1	16	32	42	34	60	45	40.5	40	96	5	28	7	46	M6
0490 03220000	- CBS20	2	20	32	42	—	60	50	—	40	97	6	28	7	46	M8
0490 04008000	ST40U - CBS08	1	8	40	50	28	70	40	33	38	101	5	20	7	56	M6
0490 04010000	- CBS10	1	10	40	50	28	70	40	33	38	101	5	23	7	56	M6
0490 04012000	- CBS12	1	12	40	50	28	70	40	33	38	101	5	23	7	56	M6
0490 04016000	- CBS16	1	16	40	50	34	70	45	39.1	40	106	5	28	7	56	M6
0490 04020000	- CBS20	1	20	40	50	42	70	50	45.5	45	107	6	33	7	56	M8
0490 04025000	- CBS25	2	25	40	50	—	70	55	—	45	112	6	33	7	56	M8

- Supported holders : Internal coolant holder of CNC lathe (U drill holder, etc.)
- Supported tool : Boring bar only
- Cutters must be inserted at least the minimum insertion length. If the minimum insertion length is not met, the seal stopper will not function and coolant will leak.

Order Example

ST25U - CBS08
Shank size I.D.

Polygon Taper Shank Tooling Series

Shank size : C3 ~ C6 ISO 26623-1 / JIS B 6066-1

High repeat-mounting accuracy.

The polygon coupling ensures excellent accuracy in rotational direction.

Product details



NT TOOL CORPORATION

2023.06.

TECHNO MAIL technomail@nttool.co.jp For technical question, please contact us by technomail.

NT TOOL CORPORATION (HEAD OFFICE) : en.nttool.com
NT USA CORPORATION (OFFICE) : www.nttoolusa.com

NT TOOL EUROPE GmbH (OFFICE) : www.nttooleurope.com
NT TOOL THAI CO., LTD. (OFFICE) : nttoothai.com

NT TOOL DE MEXICO S.A. DE C.V. (OFFICE) : www.nttool.com.mx