

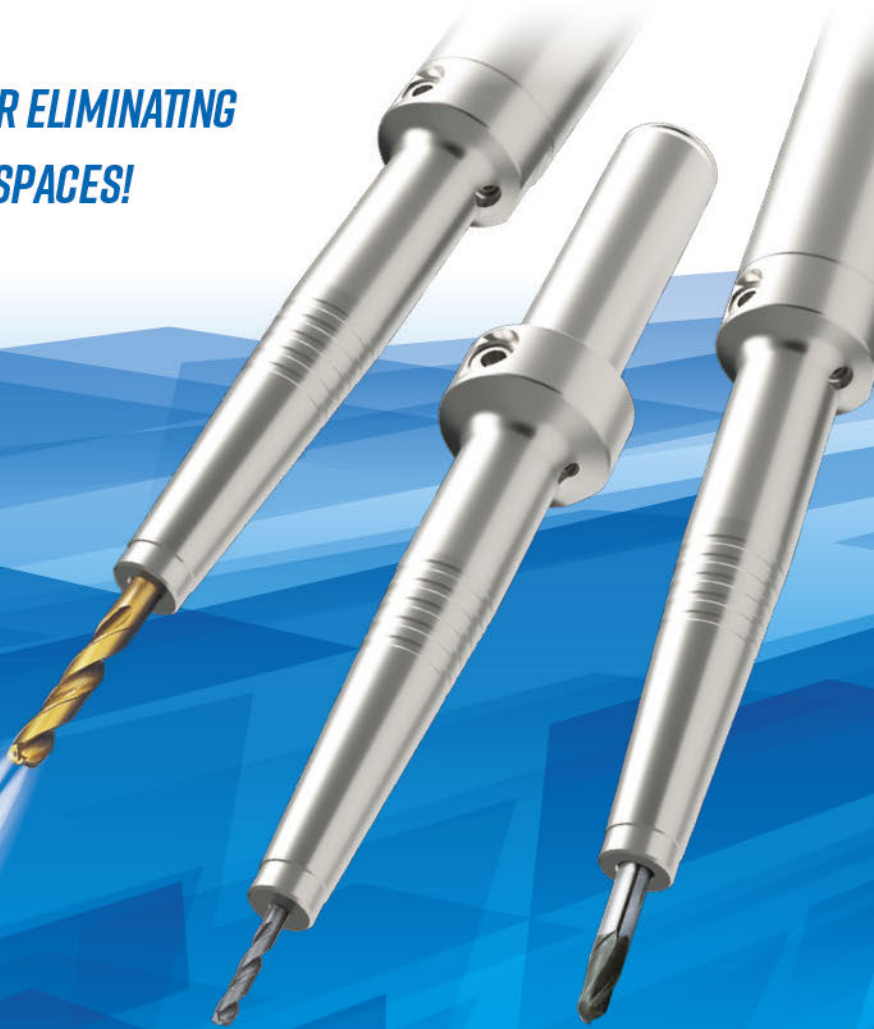

STRAIGHT HYDRO CHUCK ST-PHC-SB

*THESE SLIM TOOLS ARE OPTIMIZED FOR ELIMINATING
WORKPIECE INTERFERENCE IN TIGHT SPACES!*

- Easy! Quick! Simple Clamping!
- Center Through Coolant Feeding compliant
- Repeat Accuracy 1 μ m
- Anti-vibration effect provides better surface



Runout accuracy
(Projection length : 4d)
3 μ m

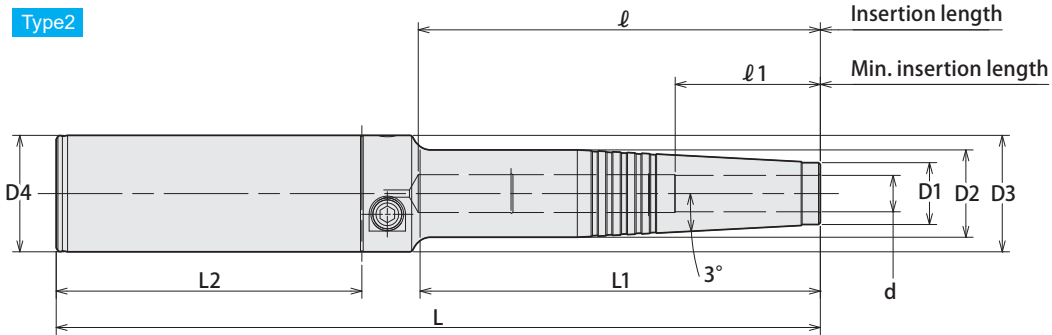
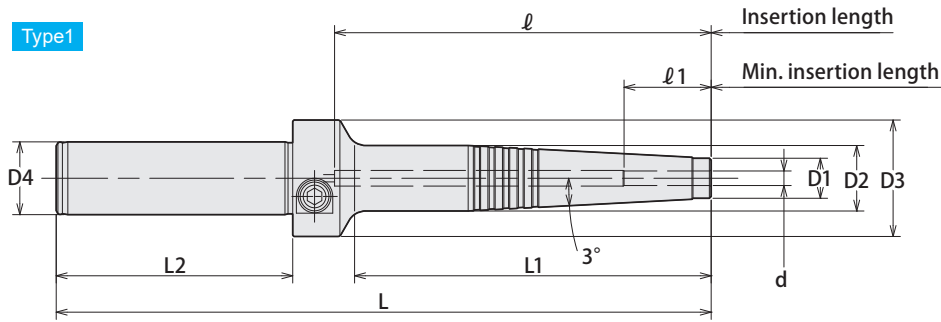

Metric Sizes Unit : Metric

Code	Model	Type	d	L	L1	L2	D1	D2	D3	D4	l	l1	Wrench(Optional)
0450 02003180	ST20 -PHC03SB -180	1	3	180	98	65	11	18	32	20	103	16	L-4T
0450 02004180	-PHC04SB -180	1	4	180	98	65	11	18	32	20	103	19	
0450 02006180	-PHC06SB -180	1	6	180	99	65	13	20	32	20	103	27	
0450 02008180	-PHC08SB -180	1	8	180	99	65	15	22	32	20	101	27	
0450 02010180	-PHC10SB -180	1	10	180	100	65	17	24	32	20	101	33	
0450 02012180	-PHC12SB -180	1	12	180	100	65	19	26	32	20	101	36	
0450 03206210	ST32 -PHC06SB -210	2	6	210	109	84	13	20	32	32	113	27	
0450 03208210	-PHC08SB -210	2	8	210	109	84	15	22	32	32	111	27	
0450 03210210	-PHC10SB -210	2	10	210	110	84	17	24	32	32	111	33	
0450 03212210	-PHC12SB -210	2	12	210	110	84	19	26	32	32	111	36	

Inch Sizes Unit : Metric

Code	Model	Type	d	L	L1	L2	D1	D2	D3	D4	l	l1	Wrench(Optional)
0450 12404180	ST0750 -PHC0125SB -180	1	3.175	180	98	65	11	18	32	19.05	103	16	L-4T
0450 12408180	-PHC0250SB -180	1	6.35	180	99	65	13	20	32	19.05	103	27	
0450 12412180	-PHC0375SB -180	1	9.525	180	100	65	17	24	32	19.05	101	33	
0450 12416180	-PHC0500SB -180	1	12.7	180	100	65	20	26	32	19.05	101	36	
0450 14008210	ST1250 -PHC0250SB -210	2	6.35	210	109	84	13	20	31.75	31.75	113	27	
0450 14012210	-PHC0375SB -210	2	9.525	210	110	84	17	24	31.75	31.75	111	33	
0450 14016210	-PHC0500SB -210	2	12.7	210	110	84	20	26	31.75	31.75	111	36	

1. Tool shank diameter tolerance must be within h6.
2. Permissible speed is greatly affected by the stiffness of the machine spindle and the balance of the cutting tool. Gradually increase from a low speed, and use at the proper speed.

Ordering Example

ST20 - PHC03SB - 180
Shank size I.D. Projection length