

PHC-A

パワー hidroチャック

Power Hydro Chuck

- コレットホルダのように使える手軽な hidroチャックです。高精度加工に最適。
Hydro chuck with collet holder flexibility. Suitable for high precision cutting.

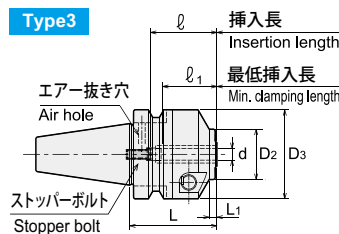
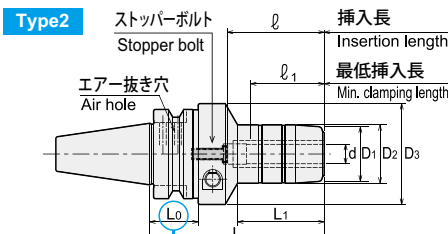
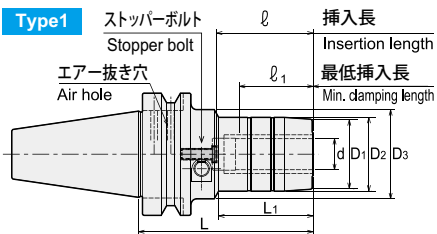

PHC04Aには stopper ボルトは付属していません。
特殊品対応(別売)にて承ります。
For PHC04A, the stopper bolt is not included.
Please order separately (Special item).

⚠ 注意 Caution
★: ATCアーム及びマガジン内での干渉にご注意ください。
★: Take caution against A.T.C. arm and tool magazine interference.

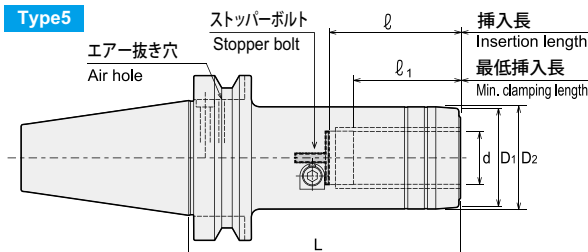
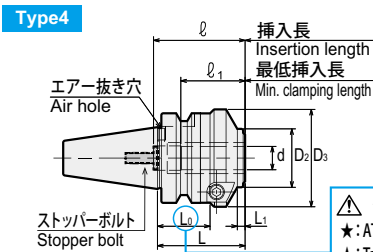

⚠ 注意 Caution
★: ATCアーム及びマガジン内での干渉にご注意ください。
★: Take caution against A.T.C. arm and tool magazine interference.

商品コード Code	型式 Model	Type	d	L	L1	D1	D2	D3	L0	ℓ	ℓ1	Kg	—	レンチ(別売) Wrench (Option)	
3930 01104065	BT30 -PHC04A -65	1	4	65	25.1	—	25	46	—	29	24	—	45,000	L-4T	
3930 01106045	-PHC06A -45	3	6	45	4	—	26	46	—	34	29	0.6	40,200		
3930 01106075	-75	1	6	75	30	24	26	46	—	34	29	0.7	41,220		
3930 01107045	-PHC07A -45	3	7	45	4	—	28	46	—	34	29	0.6	40,200		
3930 01107075	-75	1	7	75	30	26	28	46	—	34	29	0.8	41,220		
3930 01108045	-PHC08A -45	3	8	45	4	—	28	46	—	34	29	0.6	40,200		
3930 01108075	-75	1	8	75	30	26	28	46	—	34	29	0.8	41,220		
3930 01109045	-PHC09A -45	3	9	45	4	—	30	46	—	45	33	0.6	41,600		
3930 01109090	-90	1	9	90	46	28	30	46	—	55	40	0.8	42,000		
3930 01109105	-105	2	9	105	44	28	30	52	40	50	40	1.2	42,660		
3930 01110045	-PHC10A -45	3	10	45	4	—	30	46	—	45	33	0.6	41,600		
3930 01110090	-90	1	10	90	46	28	30	46	—	55	40	0.8	42,000		
3930 01110105	-105	2	10	105	44	28	30	52	40	50	40	1.2	42,660		
3930 01111045	-PHC11A -45	3	11	45	4	—	30	46	—	45	33	0.6	41,600		
3930 01111090	-90	1	11	90	46	30	32	46	—	55	40	0.9	42,000		
3930 01111105	-105	2	11	105	45	30	32	52	40	50	40	1.1	42,660		
3930 01112045	-PHC12A -45	3	12	45	4	—	30	46	—	45	33	0.6	44,600		
3930 01112090	-90	1	12	90	46	30	32	46	—	55	40	0.9	45,000		
3930 01112105	-105	2	12	105	45	30	32	52	40	50	40	1.1	45,660		
3930 01113045	-PHC13A -45	4	13	45	4	—	30	50	27	45	33	0.6	41,600		
3930 01113090	-90	1	13	90	48	34	36	46	—	55	40	0.9	42,000		
3930 01113105	-105	2	13	105	46	34	36	52	40	50	40	1.5	42,660		
3930 01114045	-PHC14A -45	4	14	45	4	—	30	50	27	45	33	0.6	41,600		
3930 01114090	-90	1	14	90	48	34	36	46	—	55	40	1.0	42,000		
3930 01114105	-105	2	14	105	46	34	36	52	40	50	40	1.2	42,660		
3930 01115045	-PHC15A -45	4	15	45	4	—	30	50	27	45	33	0.6	41,600		
3930 01115090	-90	1	15	90	48	36	38	46	—	55	40	1.0	42,000		
3930 01115105	-105	2	15	105	46	36	38	52	40	50	40	1.2	42,660		
3930 01116045	-PHC16A -45	4	16	45	4	—	30	50	27	45	33	0.6	41,600		
3930 01116090	-90	1	16	90	48	36	38	46	—	55	40	0.9	42,000		
3930 01116105	-105	2	16	105	46	36	38	52	40	50	40	1.2	42,660		
3930 01120090	-PHC20A -90	1	20	90	49	40	42	46	—	50	40	1.0	45,660		
3930 01120120	-120	1	20	120	69	40	42	46	—	70	40	1.3	46,500		
3930 01304070	BT40 -PHC04A -70	1	4	70	25.1	—	25	46	—	29	24	—	46,500		L-4T
3930 01306075	-PHC06A -75	1	6	75	30	24	26	46	—	34	29	1.3	42,700		
3930 01306105	-105	1	6	105	41	24	26	46	—	45	29	1.5	43,830		
3930 01307075	-PHC07A -75	1	7	75	30	26	28	46	—	34	29	1.3	42,700		
3930 01307105	-105	1	7	105	41	26	28	46	—	45	29	1.4	43,830		
3930 01308075	-PHC08A -75	1	8	75	30	26	28	46	—	34	29	1.3	42,700		
3930 01308105	-105	1	8	105	41	26	28	46	—	45	29	1.6	43,830		
3930 01309090	-PHC09A -90	1	9	90	44	28	30	52	—	50	40	1.4	42,570		
3930 01309120	-120	1	9	120	64	28	30	52	—	70	40	1.7	43,830		

高さ調整ユニット Length adjustment unit

高さ調整用六角レンチ
Hex Wrench for height adjustment

突き出し量が減少します。
For shorter projection length

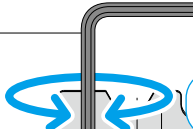

突き出し量が増加します。
For longer projection length

シャンクサイズ Shank size	高さ調整用六角レンチサイズ Hex wrench size for height adjustment	高さ調整ユニット着脱工具 Install / removal tool for length adjustment unit
BT30	2.5mm	STS-R1
BT40	2.5mm	STS-R2

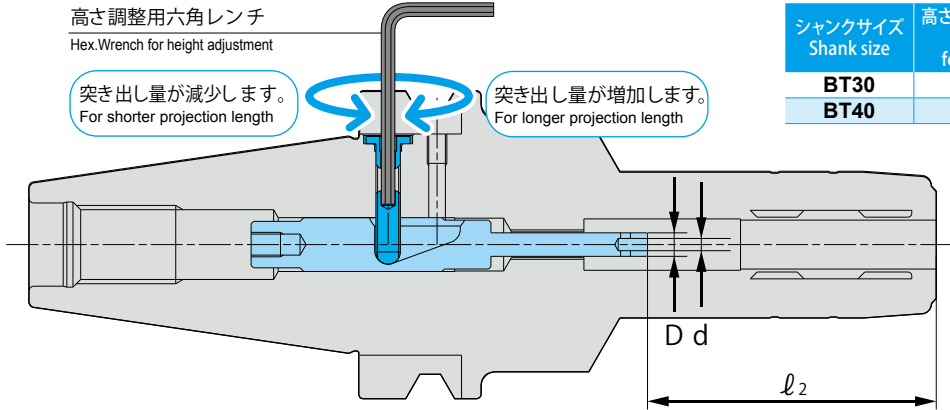

商品コード Code	高さ調整ユニット型式 Length adjustment unit	適合ホルダ型式 Matched chuck	調整範囲 l_2 Adjustment range l_2	調整量 Adjustable amount	先端内径寸法 Pin end I.D. d	先端外径寸法 Pin end O.D. D	—
3934 23044023	PHC-P304-4023	BT30 -PHC06A-75	29-34	5	2	3.8	3,200
3934 23044023	PHC-P304-4023	-PHC07A-75	29-34	5	2	3.8	3,200
3934 23044023	PHC-P304-4023	-PHC08A-75	29-34	5	2	3.8	3,200
3934 23053730	PHC-P305-3730	-PHC09A-90	40-45	5	2.5	4.8	3,200
3934 23053725	PHC-P305-3725	-90	45-50	5	2.5	4.8	3,200
3934 23053720	PHC-P305-3720	-90	50-55	5	2.5	4.8	3,200
3934 23054537	PHC-P305-4537	-105	40-45	5	2.5	4.8	3,200
3934 23054532	PHC-P305-4532	-105	45-50	5	2.5	4.8	3,200
3934 23053730	PHC-P305-3730	-PHC10A-90	40-45	5	2.5	4.8	3,200
3934 23053725	PHC-P305-3725	-90	45-50	5	2.5	4.8	3,200
3934 23053720	PHC-P305-3720	-90	50-55	5	2.5	4.8	3,200
3934 23054537	PHC-P305-4537	-105	40-45	5	2.5	4.8	3,200
3934 23054532	PHC-P305-4532	-105	45-50	5	2.5	4.8	3,200
3934 23053730	PHC-P305-3730	-PHC11A-90	40-45	5	2.5	4.8	3,200
3934 23053725	PHC-P305-3725	-90	45-50	5	2.5	4.8	3,200
3934 23053720	PHC-P305-3720	-90	50-55	5	2.5	4.8	3,200
3934 23054537	PHC-P305-4537	-105	40-45	5	2.5	4.8	3,200
3934 23054532	PHC-P305-4532	-105	45-50	5	2.5	4.8	3,200
3934 23053730	PHC-P305-3730	-PHC12A-90	40-45	5	2.5	4.8	3,200
3934 23053725	PHC-P305-3725	-90	45-50	5	2.5	4.8	3,200
3934 23053720	PHC-P305-3720	-90	50-55	5	2.5	4.8	3,200
3934 23054537	PHC-P305-4537	-105	40-45	5	2.5	4.8	3,200
3934 23054532	PHC-P305-4532	-105	45-50	5	2.5	4.8	3,200
3934 23053730	PHC-P305-3730	-PHC13A-90	40-45	5	2.5	4.8	3,200
3934 23053725	PHC-P305-3725	-90	45-50	5	2.5	4.8	3,200
3934 23053720	PHC-P305-3720	-90	50-55	5	2.5	4.8	3,200
3934 23054537	PHC-P305-4537	-105	40-45	5	2.5	4.8	3,200
3934 23054532	PHC-P305-4532	-105	45-50	5	2.5	4.8	3,200
3934 23053730	PHC-P305-3730	-PHC14A-90	40-45	5	2.5	4.8	3,200
3934 23053725	PHC-P305-3725	-90	45-50	5	2.5	4.8	3,200
3934 23053720	PHC-P305-3720	-90	50-55	5	2.5	4.8	3,200
3934 23054537	PHC-P305-4537	-105	40-45	5	2.5	4.8	3,200
3934 23054532	PHC-P305-4532	-105	45-50	5	2.5	4.8	3,200
3934 23053730	PHC-P305-3730	-PHC15A-90	40-45	5	2.5	4.8	3,200
3934 23053725	PHC-P305-3725	-90	45-50	5	2.5	4.8	3,200
3934 23053720	PHC-P305-3720	-90	50-55	5	2.5	4.8	3,200
3934 23054537	PHC-P305-4537	-105	40-45	5	2.5	4.8	3,200
3934 23054532	PHC-P305-4532	-105	45-50	5	2.5	4.8	3,200
3934 23053730	PHC-P305-3730	-PHC16A-90	40-45	5	2.5	4.8	3,200
3934 23053725	PHC-P305-3725	-90	45-50	5	2.5	4.8	3,200
3934 23053720	PHC-P305-3720	-90	50-55	5	2.5	4.8	3,200
3934 23054537	PHC-P305-4537	-105	40-45	5	2.5	4.8	3,200
3934 23054532	PHC-P305-4532	-105	45-50	5	2.5	4.8	3,200
3934 23054027	PHC-P305-4027	-PHC20A-90	40-45	5	2.5	4.8	3,200
3934 23054022	PHC-P305-4022	-90	45-50	5	2.5	4.8	3,200
3934 23054542	PHC-P305-4542	-120	50-55	5	2.5	4.8	3,200
3934 23054537	PHC-P305-4537	-120	55-60	5	2.5	4.8	3,200
3934 23054532	PHC-P305-4532	-120	60-65	5	2.5	4.8	3,200

商品コード Code	高さ調整ユニット型式 Length adjustment unit	適合ホルダ型式 Matched chuck	調整範囲ℓ2 Adjustment range ℓ2	調整量 Adjustable amount	先端内径寸法 d Pin end I.D.	先端外径寸法 D Pin end O.D.	—
3934 24044423	PHC-P404-4423	BT40 -PHC06A -75	29-34	5	2	3.8	3,200
3934 24046334	PHC-P404-6334	-105	29-39	10	2	3.8	3,200
3934 24046328	PHC-P404-6328	-105	35-45	10	2	3.8	3,200
3934 24044423	PHC-P404-4423	-PHC07A -75	29-34	5	2	3.8	3,200
3934 24046334	PHC-P404-6334	-105	29-39	10	2	3.8	3,200
3934 24046328	PHC-P404-6328	-105	35-45	10	2	3.8	3,200
3934 24044423	PHC-P404-4423	-PHC08A -75	29-34	5	2	3.8	3,200
3934 24046334	PHC-P404-6334	-105	29-39	10	2	3.8	3,200
3934 24046328	PHC-P404-6328	-105	35-45	10	2	3.8	3,200
3934 24054427	PHC-P405-4427	-PHC09A -90	40-50	10	2.5	4.8	3,200
3934 24054952	PHC-P405-4952	-120	40-50	10	2.5	4.8	3,200
3934 24054942	PHC-P405-4942	-120	50-60	10	2.5	4.8	3,200
3934 24054932	PHC-P405-4932	-120	60-70	10	2.5	4.8	3,200
3934 24054427	PHC-P405-4427	-PHC10A -90	40-50	10	2.5	4.8	3,200
3934 24054952	PHC-P405-4952	-120	40-50	10	2.5	4.8	3,200
3934 24054942	PHC-P405-4942	-120	50-60	10	2.5	4.8	3,200
3934 24054932	PHC-P405-4932	-120	60-70	10	2.5	4.8	3,200
3934 24054427	PHC-P405-4427	-PHC11A -90	40-50	10	2.5	4.8	3,200
3934 24054952	PHC-P405-4952	-120	40-50	10	2.5	4.8	3,200
3934 24054942	PHC-P405-4942	-120	50-60	10	2.5	4.8	3,200
3934 24054932	PHC-P405-4932	-120	60-70	10	2.5	4.8	3,200
3934 24054427	PHC-P405-4427	-PHC12A -90	40-50	10	2.5	4.8	3,200
3934 24054952	PHC-P405-4952	-120	40-50	10	2.5	4.8	3,200
3934 24054942	PHC-P405-4942	-120	50-60	10	2.5	4.8	3,200
3934 24054932	PHC-P405-4932	-120	60-70	10	2.5	4.8	3,200
3934 24054427	PHC-P405-4427	-PHC13A -90	40-50	10	2.5	4.8	3,200
3934 24054952	PHC-P405-4952	-120	40-50	10	2.5	4.8	3,200
3934 24054942	PHC-P405-4942	-120	50-60	10	2.5	4.8	3,200
3934 24054932	PHC-P405-4932	-120	60-70	10	2.5	4.8	3,200
3934 24054427	PHC-P405-4427	-PHC14A -90	40-50	10	2.5	4.8	3,200
3934 24054952	PHC-P405-4952	-120	40-50	10	2.5	4.8	3,200
3934 24054942	PHC-P405-4942	-120	50-60	10	2.5	4.8	3,200
3934 24054932	PHC-P405-4932	-120	60-70	10	2.5	4.8	3,200
3934 24054427	PHC-P405-4427	-PHC15A -90	40-50	10	2.5	4.8	3,200
3934 24054952	PHC-P405-4952	-120	40-50	10	2.5	4.8	3,200
3934 24054942	PHC-P405-4942	-120	50-60	10	2.5	4.8	3,200
3934 24054932	PHC-P405-4932	-120	60-70	10	2.5	4.8	3,200
3934 24054427	PHC-P405-4427	-PHC16A -90	40-50	10	2.5	4.8	3,200
3934 24054952	PHC-P405-4952	-120	40-50	10	2.5	4.8	3,200
3934 24054942	PHC-P405-4942	-120	50-60	10	2.5	4.8	3,200
3934 24054932	PHC-P405-4932	-120	60-70	10	2.5	4.8	3,200
3934 24054427	PHC-P405-4427	-PHC20A -90	40-50	10	2.5	4.8	3,200
3934 24054952	PHC-P405-4952	-120	40-50	10	2.5	4.8	3,200
3934 24054942	PHC-P405-4942	-120	50-60	10	2.5	4.8	3,200
3934 24054932	PHC-P405-4932	-120	60-70	10	2.5	4.8	3,200
3934 24054432	PHC-P405-4432	-PHC25A -105	50-60	10	2.5	4.8	3,200
3934 24055452	PHC-P405-5452	-135	50-60	10	2.5	4.8	3,200
3934 24055442	PHC-P405-5442	-135	60-70	10	2.5	4.8	3,200
3934 24055432	PHC-P405-5432	-135	70-80	10	2.5	4.8	3,200
3934 24054432	PHC-P405-4432	-PHC32A -120	65-75	10	2.5	4.8	3,200
3934 24055452	PHC-P405-5452	-150	65-75	10	2.5	4.8	3,200
3934 24054952	PHC-P405-4952	-150	70-80	10	2.5	4.8	3,200

ご注文例 Ordering Example

BT30-PHC10A-105にて調整範囲40-45mm (調整量5mm)で調整する場合
BT30-PHC10A-105 with adjustment range of 40-45mm (Adjustable amount-5mm).

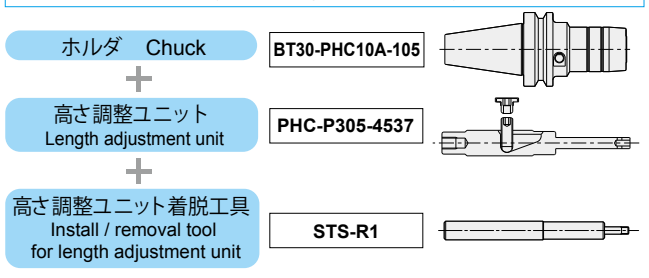

- 高さ調整ユニットは突き出し長さ45mmのホルダには使用できません。
 - 高さ調整ユニットはBT、CAT、SKシャンクホルダにのみ使用可能です。
 - PHC04Aには高さ調整ユニットはご使用いただけません。
- Length adjustment unit can be used for Chucks other than 45mm projection length.
 - Length adjustment unit can be used with BT, CAT and SK shank Chucks only.
 - For PHC04A, the length adjustment unit cannot be used.

高さ調整ユニット Length adjustment unit

高さ調整用六角レンチ
Hex Wrench for height adjustment

突き出し量が減少します。
For shorter projection length

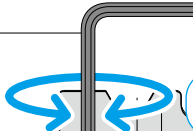

突き出し量が増加します。
For longer projection length

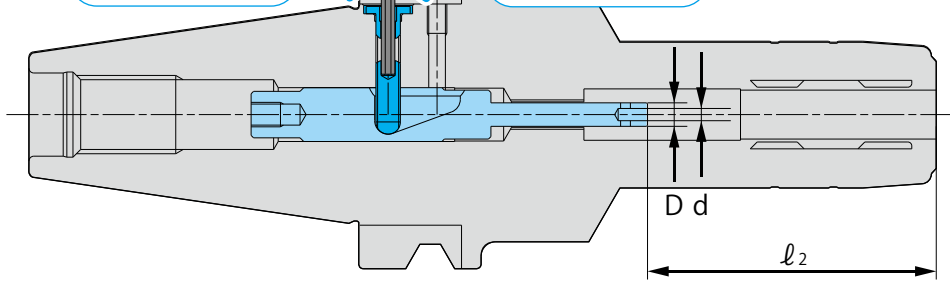

シャンクサイズ Shank size	高さ調整用六角レンチサイズ Hex wrench size for height adjustment	高さ調整ユニット着脱工具 Install / removal tool for length adjustment unit
BT50	3mm	STS-R2

商品コード Code	高さ調整ユニット型式 Length adjustment unit	適合ホルダ型式 Matched chuck	調整範囲 l_2 Adjustment range l_2	調整量 Adjustable amount	先端内径寸法 Pin end I.D. d	先端外径寸法 Pin end O.D. D	—
3934 25045129	PHC-P504-5129	BT50 -PHC06A-90	29-34	5	2	3.8	3,200
3934 25047139	PHC-P504-7139	-120	29-45	16	2	3.8	3,200
3934 25040139	PHC-P504-10139	-150	29-45	16	2	3.8	3,200
3934 25045129	PHC-P504-5129	-PHC07A-90	29-34	5	2	3.8	3,200
3934 25047139	PHC-P504-7139	-120	29-45	16	2	3.8	3,200
3934 25040139	PHC-P504-10139	-150	29-45	16	2	3.8	3,200
3934 25045129	PHC-P504-5129	-PHC08A-90	29-34	5	2	3.8	3,200
3934 25047139	PHC-P504-7139	-120	29-45	16	2	3.8	3,200
3934 25040139	PHC-P504-10139	-150	29-45	16	2	3.8	3,200
3934 25055133	PHC-P505-5133	-PHC09A-105	40-50	10	2.5	4.8	3,200
3934 25056153	PHC-P505-6153	-135	40-55	15	2.5	4.8	3,200
3934 25056138	PHC-P505-6138	-135	55-70	15	2.5	4.8	3,200
3934 25059153	PHC-P505-9153	-165	40-55	15	2.5	4.8	3,200
3934 25059138	PHC-P505-9138	-165	55-70	15	2.5	4.8	3,200
3934 25055133	PHC-P505-5133	-PHC10A-105	40-50	10	2.5	4.8	3,200
3934 25056153	PHC-P505-6153	-135	40-55	15	2.5	4.8	3,200
3934 25056138	PHC-P505-6138	-135	55-70	15	2.5	4.8	3,200
3934 25059153	PHC-P505-9153	-165	40-55	15	2.5	4.8	3,200
3934 25059138	PHC-P505-9138	-165	55-70	15	2.5	4.8	3,200
3934 25055133	PHC-P505-5133	-PHC11A-105	40-50	10	2.5	4.8	3,200
3934 25056153	PHC-P505-6153	-135	40-55	15	2.5	4.8	3,200
3934 25056138	PHC-P505-6138	-135	55-70	15	2.5	4.8	3,200
3934 25059153	PHC-P505-9153	-165	40-55	15	2.5	4.8	3,200
3934 25059138	PHC-P505-9138	-165	55-70	15	2.5	4.8	3,200
3934 25055133	PHC-P505-5133	-PHC12A-105	40-50	10	2.5	4.8	3,200
3934 25056153	PHC-P505-6153	-135	40-55	15	2.5	4.8	3,200
3934 25056138	PHC-P505-6138	-135	55-70	15	2.5	4.8	3,200
3934 25059153	PHC-P505-9153	-165	40-55	15	2.5	4.8	3,200
3934 25059138	PHC-P505-9138	-165	55-70	15	2.5	4.8	3,200
3934 25055133	PHC-P505-5133	-PHC13A-105	40-50	10	2.5	4.8	3,200
3934 25056153	PHC-P505-6153	-135	40-55	15	2.5	4.8	3,200
3934 25056138	PHC-P505-6138	-135	55-70	15	2.5	4.8	3,200
3934 25059153	PHC-P505-9153	-165	40-55	15	2.5	4.8	3,200
3934 25059138	PHC-P505-9138	-165	55-70	15	2.5	4.8	3,200
3934 25055133	PHC-P505-5133	-PHC14A-105	40-50	10	2.5	4.8	3,200
3934 25056153	PHC-P505-6153	-135	40-55	15	2.5	4.8	3,200
3934 25056138	PHC-P505-6138	-135	55-70	15	2.5	4.8	3,200
3934 25059153	PHC-P505-9153	-165	40-55	15	2.5	4.8	3,200
3934 25059138	PHC-P505-9138	-165	55-70	15	2.5	4.8	3,200
3934 25055133	PHC-P505-5133	-PHC15A-105	40-50	10	2.5	4.8	3,200
3934 25056153	PHC-P505-6153	-135	40-55	15	2.5	4.8	3,200
3934 25056138	PHC-P505-6138	-135	55-70	15	2.5	4.8	3,200
3934 25059153	PHC-P505-9153	-165	40-55	15	2.5	4.8	3,200
3934 25059138	PHC-P505-9138	-165	55-70	15	2.5	4.8	3,200
3934 25055133	PHC-P505-5133	-PHC16A-105	40-50	10	2.5	4.8	3,200
3934 25056153	PHC-P505-6153	-135	40-55	15	2.5	4.8	3,200
3934 25056138	PHC-P505-6138	-135	55-70	15	2.5	4.8	3,200
3934 25059153	PHC-P505-9153	-165	40-55	15	2.5	4.8	3,200
3934 25059138	PHC-P505-9138	-165	55-70	15	2.5	4.8	3,200

商品コード Code	高さ調整ユニット型式 Length adjustment unit	適合ホルダ型式 Matched chuck	調整範囲 ℓ2 Adjustment range ℓ2	調整量 Adjustable amount	先端内径寸法 d Pin end I.D.	先端外径寸法 D Pin end O.D.	—
3934 25055133	PHC-P505-5133	BT50 -PHC20A-105	40-50	10	2.5	4.8	3,200
3934 25056153	PHC-P505-6153	-135	40-55	15	2.5	4.8	3,200
3934 25056138	PHC-P505-6138	-135	55-70	15	2.5	4.8	3,200
3934 25059153	PHC-P505-9153	-165	40-55	15	2.5	4.8	3,200
3934 25059138	PHC-P505-9138	-165	55-70	15	2.5	4.8	3,200
3934 25055138	PHC-P505-5138	-PHC25A-120	50-64	14	2.5	4.8	3,200
3934 25056158	PHC-P505-6158	-150	50-65	15	2.5	4.8	3,200
3934 25056143	PHC-P505-6143	-150	65-80	15	2.5	4.8	3,200
3934 25057658	PHC-P505-7658	-165	50-65	15	2.5	4.8	3,200
3934 25057643	PHC-P505-7643	-165	65-80	15	2.5	4.8	3,200
3934 25055138	PHC-P505-5138	-PHC32A-135	65-75	10	2.5	4.8	3,200
3934 25056158	PHC-P505-6158	-165	65-80	15	2.5	4.8	3,200

ご注文例 Ordering Example

BT50-PHC10A-105にて調整範囲40-45mm (調整量5mm) で調整する場合
BT50-PHC10A-105 with adjustment range of 40-45mm (Adjustable amount-5mm).

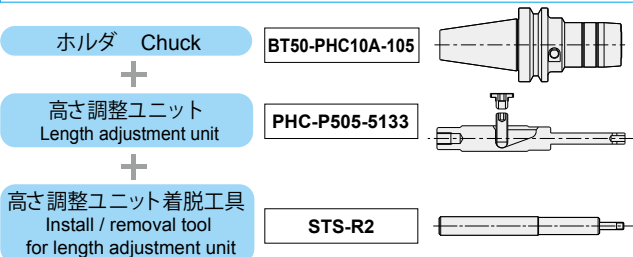

- 高さ調整ユニットは突き出し長さ45mmのホルダには使用できません。
 - 高さ調整ユニットはBT、CAT、SKシャンクホルダにのみ使用可能です。
 - PHC04Aには高さ調整ユニットはご使用いただけません。
- Length adjustment unit can be used for Chucks other than 45mm projection length.
 - Length adjustment unit can be used with BT, CAT and SK shank Chucks only.
 - For PHC04A, the length adjustment unit cannot be used.

スリップ防止ピン付コレット Collet with stopper pin

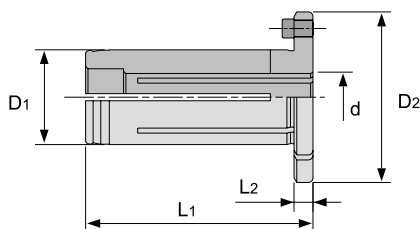

最低挿入長一覧
Min. Clamping length

コレット内径 [d] Collet I.D. [d]	最低挿入長 Min. Clamping length
3, 4	25
5	30
6, 7	34
8, 9	38
10, 11	42
12, 13, 14, 15, 16	50

● 穴付き刃具用 OH 型 For cutter with oil hole



商品コード Code	型式 Model	D1	D2	L1	L2	[d]	—
3940 300512※※	PHS 12 - [d] -OH	12	26	48	4	3, 4, 5, 6, 7, 8, 9, 10	8,600
3940 300520※※	PHS 20 - [d] -OH	20	36	48	4	3, 4, 5, 6, 7, 8, 9, 10 11, 12, 13, 14, 15, 16	8,600

● コレットスルー用 C 型 For collet through coolant



商品コード Code	型式 Model	D1	D2	L1	L2	[d]	—
3940 300612※※	PHS 12 - [d] -C	12	26	48	4	3, 4, 5, 6, 7, 8, 9	8,800
3940 300620※※	PHS 20 - [d] -C	20	36	48	4	3, 4, 5, 6, 7, 8, 9, 10 11, 12, 13, 14, 15, 16	8,800

商品コードの※※には内径 d が入ります。

- コレットは PHC12A、PHC20A にのみご使用できます。
 - 高さ調整ユニットとの併用が可能です。
- The collet with stopper pin can be used with PHC12A and PHC20A only.
 - The collet with stopper pin can be used with the length adjustment unit.

ご注文例 Ordering Example

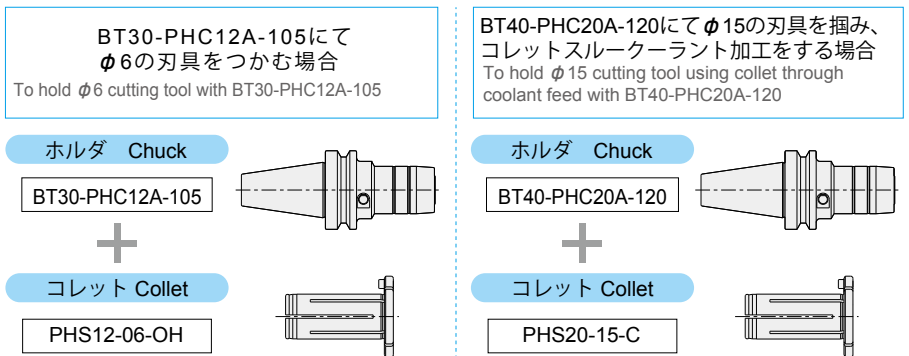

PHC-A

パワー hidroチャック

Power Hydro Chuck

- コレットホルダのように使える手軽な hidroチャックです。高精度加工に最適。
Hydro chuck with collet holder flexibility. Suitable for high precision cutting.

ストップバーボルト Stopper bolt PHC04Aにはストップバーボルトは付属しておりません。特殊品対応(別売)にて承ります。
For PHC04A, the stopper bolt is not included. Please order separately (Special item).

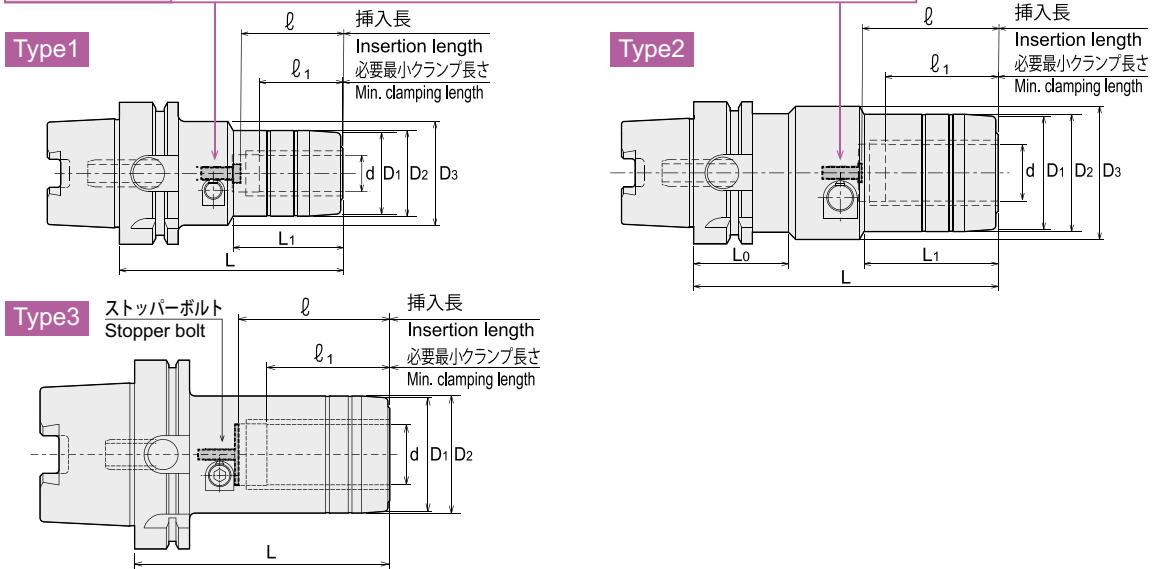

商品コード Code	型式 Model	Type	d	L	L1	D1	D2	D3	L0	ℓ	ℓ1	Kg	—	レンチ(別売) Wrench (Option)
5730 13204080	HSK40A -PHC04A -80	2	4	80	25.1	—	25	46	35	29	24		60,000	L-4T
5730 13206090	-PHC06A -90	2	6	90	30	24	26	46	35	34	29		58,800	
5730 13207090	-PHC07A -90	2	7	90	30	26	28	46	35	34	29	0.7	58,800	
5730 13208090	-PHC08A -90	2	8	90	30	26	28	46	35	34	29		58,800	
5730 13209105	-PHC09A -105	2	9	105	44	28	30	52	35	50	40		56,400	
5730 13210105	-PHC10A -105	2	10	105	44	28	30	52	35	50	40	0.9	56,400	
5730 13211105	-PHC11A -105	2	11	105	45	30	32	52	35	50	40		56,400	
5730 13212105	-PHC12A -105	2	12	105	45	30	32	52	35	50	40	0.9	59,400	
5730 13213105	-PHC13A -105	2	13	105	46	34	36	52	35	50	40		56,400	
5730 13214105	-PHC14A -105	2	14	105	46	34	36	52	35	50	40		56,400	
5730 13215105	-PHC15A -105	2	15	105	46	36	38	52	35	50	40		56,400	
5730 13216105	-PHC16A -105	2	16	105	46	36	38	52	35	50	40	1.0	56,400	
5730 13220105	-PHC20A -105	2	20	105	49	40	42	46	35	50	40	1.0	59,400	
5730 13225120	-PHC25A -120	2	25	120	59	50	52	59	35	60	50		58,500	
5730 14204085	HSK50A -PHC04A -85	2	4	85	25.1	—	25	46	42	29	24		60,000	L-4T
5730 14206090	-PHC06A -90	2	6	90	30	24	26	46	41	34	29	0.9	58,800	
5730 14207090	-PHC07A -90	2	7	90	30	26	28	46	41	34	29		58,800	
5730 14208090	-PHC08A -90	2	8	90	30	26	28	46	41	34	29	0.9	58,800	
5730 14209105	-PHC09A -105	2	9	105	44	28	30	52	41	50	40		56,400	
5730 14210105	-PHC10A -105	2	10	105	44	28	30	52	41	50	40	1.0	56,400	
5730 14211105	-PHC11A -105	2	11	105	45	30	32	52	41	50	40		56,400	
5730 14212105	-PHC12A -105	2	12	105	45	30	32	52	41	50	40	1.1	59,400	
5730 14213105	-PHC13A -105	2	13	105	46	34	36	52	41	50	40		56,400	
5730 14214105	-PHC14A -105	2	14	105	46	34	36	52	41	50	40		56,400	
5730 14215105	-PHC15A -105	2	15	105	46	36	38	52	41	50	40		56,400	
5730 14216105	-PHC16A -105	2	16	105	46	36	38	52	41	50	40	1.1	56,400	
5730 14220105	-PHC20A -105	2	20	105	49	40	42	46	41	50	40	1.1	59,400	
5730 14225135	-PHC25A -135	2	25	135	59	50	52	59	42	60	50	1.9	58,500	
5730 15204070	HSK63A -PHC04A -70	1	4	70	25.1	—	25	46	—	29	24		60,000	L-6T
5730 15206075	-PHC06A -75	1	6	75	30	24	26	46	—	34	29	1.0	58,800	
5730 15206120	-120	1	6	120	41	24	26	46	—	45	29	1.5	60,000	
5730 15207075	-PHC07A -75	1	7	75	30	26	28	46	—	34	29		58,800	
5730 15207120	-120	1	7	120	41	26	28	46	—	45	29		60,000	
5730 15208075	-PHC08A -75	1	8	75	30	26	28	46	—	34	29	1.0	58,800	
5730 15208120	-120	1	8	120	41	26	28	46	—	45	29	1.5	60,000	
5730 15209090	-PHC09A -90	1	9	90	44	28	30	52	—	50	40		57,000	
5730 15209120	-120	1	9	120	64	28	30	52	—	70	40		58,100	
5730 15210090	-PHC10A -90	1	10	90	44	28	30	52	—	50	40	1.1	57,000	
5730 15210120	-120	1	10	120	64	28	30	52	—	70	40	1.4	58,100	
5730 15211090	-PHC11A -90	1	11	90	45	30	32	52	—	50	40	1.2	57,000	
5730 15211120	-120	1	11	120	65	30	32	52	—	70	40	1.4	58,100	

PHC-A

パワー hidroチャック

Power Hydro Chuck

- コレットホルダのように使える手軽な hidroチャックです。高精度加工に最適。
Hydro chuck with collet holder flexibility. Suitable for high precision cutting.

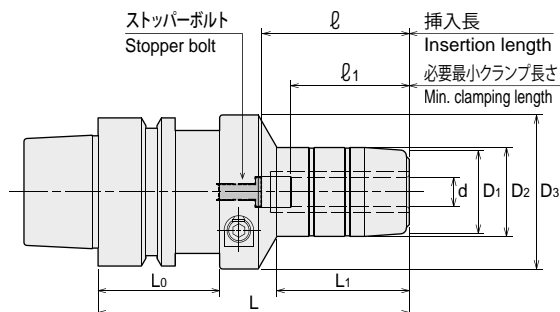

商品コード Code	型式 Model	d	L	L1	D1	D2	D3	L0	ℓ	ℓ1	Kg	—	レンチ (別売) Wrench (Option)
5730 53206090	HSK40E -PHC06A -90	6	90	30	24	26	46	35	34	29	0.7	58,800	L-4T
5730 53207090	-PHC07A -90	7	90	30	26	28	46	35	34	29	58,800		
5730 53208090	-PHC08A -90	8	90	30	26	28	46	35	34	29	58,800		
5730 53209105	-PHC09A -105	9	105	44	28	30	52	35	50	40	56,400		
5730 53210105	-PHC10A -105	10	105	44	28	30	52	35	50	40	56,400		
5730 53211105	-PHC11A -105	11	105	45	30	32	52	35	50	40	56,400		
5730 53212105	-PHC12A -105	12	105	45	30	32	52	35	50	40	59,400		
5730 54206090	HSK50E -PHC06A -90	6	90	30	24	26	46	41	34	29	0.9	58,800	L-4T
5730 54207090	-PHC07A -90	7	90	30	26	28	46	41	34	29	58,800		
5730 54208090	-PHC08A -90	8	90	30	26	28	46	41	34	29	58,800		
5730 54209105	-PHC09A -105	9	105	44	28	30	52	41	50	40	56,400		
5730 54210105	-PHC10A -105	10	105	44	28	30	52	41	50	40	56,400		
5730 54211105	-PHC11A -105	11	105	45	30	32	52	41	50	40	56,400		
5730 54212105	-PHC12A -105	12	105	45	30	32	52	41	50	40	59,400		
5730 54213105	-PHC13A -105	13	105	46	34	36	52	41	50	40	56,400		
5730 54214105	-PHC14A -105	14	105	46	34	36	52	41	50	40	56,400		
5730 54215105	-PHC15A -105	15	105	46	36	38	52	41	50	40	56,400		
5730 54216105	-PHC16A -105	16	105	46	36	38	52	41	50	40	56,400		
5730 54220105	-PHC20A -105	20	105	49	40	42	46	41	50	40	59,400		

1. 刃具シャンクは h7 公差以下のシャンクをご使用下さい。新規に刃具を製作される場合は $0_{-0.01}$ 公差で製作されることをお勧めいたします。
2. ホルダを空締めしたまま放置しないでください。
3. PHC12A、PHC20A にはスリップ防止ピン付コレット装着用の穴が開いています。
 1. Please use a cutting tool with a tolerance of less than h7. A tolerance of less than 0/-001 is recommended for new cutting tools.
 2. Do not leave the holder with actuating screw tightened when the chuck is empty.
 3. PHC12A and PHC20A have pin holes for collet with stopper pin on its body.

ご注文例 Ordering Example

HSK50E - PHC12A- 105

シャンクサイズ 内径 (d) 突き出し長さ (L)
Shank size I.D. Projction length

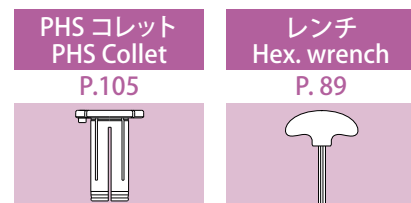

PHC-A

パワー hidroチャック

Power Hydro Chuck

- コレットホルダのように使える手軽な hidroチャックです。高精度加工に最適。
Hydro chuck with collet holder flexibility. Suitable for high precision cutting.

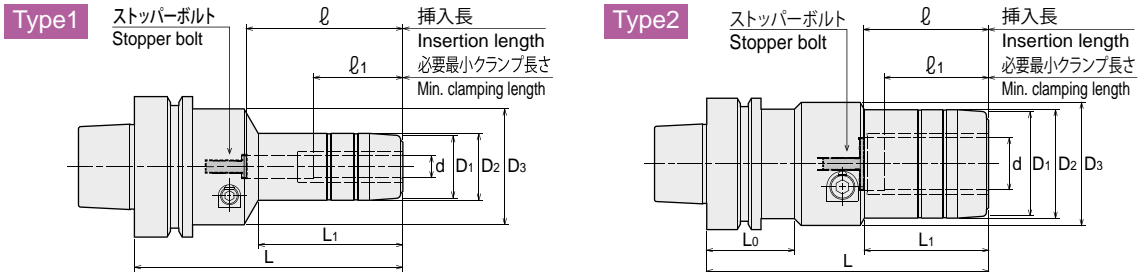

商品コード Code	型式 Model	Type	d	L	L1	D1	D2	D3	L0	l	l1	Kg	—	レンチ (別売) Wrench (Option)
5730 65206075	HSK63F -PHC06A -75	1	6	75	30	24	26	46	—	34	29	1.0	64,680	L-4T
5730 65206120	-120	1	6	120	41	24	26	46	—	45	29		66,000	
5730 65207075	-PHC07A -75	1	7	75	30	26	28	46	—	34	29		64,680	
5730 65207120	-120	1	7	120	41	26	28	46	—	45	29		66,000	
5730 65208075	-PHC08A -75	1	8	75	30	26	28	46	—	34	29		64,680	
5730 65208120	-120	1	8	120	41	26	28	46	—	45	29		66,000	
5730 65209090	-PHC09A -90	1	9	90	44	28	30	52	—	50	40		62,700	
5730 65209120	-120	1	9	120	64	28	30	52	—	70	40		63,900	
5730 65210090	-PHC10A -90	1	10	90	44	28	30	52	—	50	40		62,700	
5730 65210120	-120	1	10	120	64	28	30	52	—	70	40		63,900	
5730 65211090	-PHC11A -90	1	11	90	45	30	32	52	—	50	40		62,700	
5730 65211120	-120	1	11	120	65	30	32	52	—	70	40		63,900	
5730 65212090	-PHC12A -90	1	12	90	45	30	32	52	—	50	40		66,000	
5730 65212120	-120	1	12	120	65	30	32	52	—	70	40		67,200	
5730 65213090	-PHC13A -90	1	13	90	46	34	36	52	—	50	40		62,700	
5730 65213120	-120	1	13	120	66	34	36	52	—	70	40		63,900	
5730 65214090	-PHC14A -90	1	14	90	46	34	36	52	—	50	40		62,700	
5730 65214120	-120	1	14	120	66	34	36	52	—	70	40		63,900	
5730 65215090	-PHC15A -90	1	15	90	46	36	38	52	—	50	40		62,700	
5730 65215120	-120	1	15	120	66	36	38	52	—	70	40		63,900	
5730 65216090	-PHC16A -90	1	16	90	46	36	38	52	—	50	40		62,700	
5730 65216120	-120	1	16	120	66	36	38	52	—	70	40		63,900	
5730 65220090	-PHC20A -90	1	20	90	49	40	42	46	—	50	40		66,000	
5730 65220120	-120	1	20	120	69	40	42	46	—	70	40		67,200	
5730 65225135	-PHC25A -135	2	25	135	59	50	52	59	42	60	50		64,000	
5730 65225150	-150	2	25	150	79	50	52	59	42	80	50		67,200	
5730 65232135	-PHC32A -135	2	32	135	42	60	62	85	42	80	65		64,000	
5730 65232150	-150	2	32	150	108	60	62	62	42	80	65		67,200	
														L-6T

1. 刃具シャクは h7 公差以下のシャクをご使用下さい。新規に刃具を製作される場合は $0_{.01}$ 公差で製作されることをお勧めいたします。
2. ホルダを空締めたまま放置しないでください。
3. PHC12A、PHC20A にはスリップ防止ピン付コレット装着用の穴が開いています。
 1. Please use a cutting tool with a tolerance of less than h7. A tolerance of less than 0/-001 is recommended for new cutting tools.
 2. Do not leave the holder with actuating screw tightened when the chuck is empty.
 3. PHC12A and PHC20A have pin holes for collet with stopper pin on its body.

ご注文例 Ordering Example

HSK63F - PHC12A - 120

シャクサイズ 内径 (d) 突き出し長さ (L)
Shank size I.D. Projction length

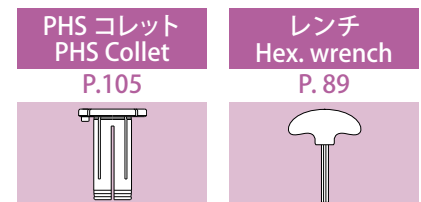

PHC-A

パワーハイドロチャック

Power Hydro Chuck

- コレットホルダのように使える手軽なハイドロチャックです。高精度加工に最適。
Hydro chuck with collet holder flexibility. Suitable for high precision cutting.

ストッパーボルト Stopper bolt
PHC04Aにはストッパーボルトは付属しておりません。特殊品対応(別売)にて承ります。For PHC04A, the stopper bolt is not included. Please order separately (Special item).

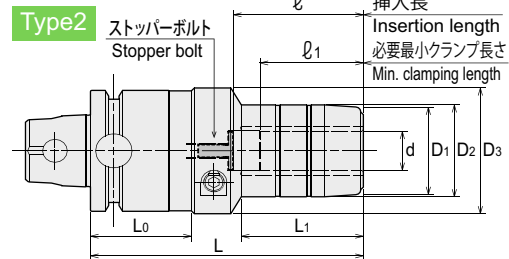
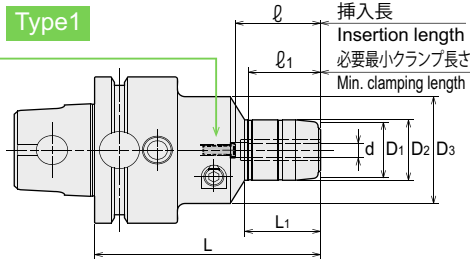

商品コード Code	型式 Model	Type	d	L	L1	D1	D2	D3	L0	l	l1	Kg	—	レンチ(別売) Wrench (Option)
1390 11104075	UTS5040 -PHC04A -75-H	1	4	75	25.1	—	25	46	—	29	24	—	60,000	L-4T
1390 11106090	-PHC06A -90-H	1	6	90	30	24	26	46	—	34	29	1.0	58,800	
1390 11107090	-PHC07A -90-H	1	7	90	30	26	28	46	—	34	29	1.0	58,800	
1390 11108090	-PHC08A -90-H	1	8	90	30	26	28	46	—	34	29	1.0	58,800	
1390 11109105	-PHC09A -105-H	2	9	105	44	28	30	52	38	50	40	1.1	56,400	
1390 11110105	-PHC10A -105-H	2	10	105	44	28	30	52	38	50	40	1.1	56,400	
1390 11111105	-PHC11A -105-H	2	11	105	45	30	32	52	38	50	40	1.1	56,400	
1390 11112105	-PHC12A -105-H	2	12	105	45	30	32	52	38	50	40	1.1	59,400	
1390 11113105	-PHC13A -105-H	2	13	105	46	34	36	52	38	50	40	1.2	56,400	
1390 11114105	-PHC14A -105-H	2	14	105	46	34	36	52	38	50	40	1.2	56,400	
1390 11115105	-PHC15A -105-H	2	15	105	46	36	38	52	38	50	40	1.2	56,400	
1390 11116105	-PHC16A -105-H	2	16	105	46	36	38	52	38	50	40	1.2	56,400	
1390 11120105	-PHC20A -105-H	1	20	105	49	40	42	46	—	50	40	1.2	59,400	
1390 1※204080	UTS6350 -PHC04A -80	1	4	80	25.1	—	25	46	—	29	24	—	60,000	
1390 1※206090	-PHC06A -90	1	6	90	30	24	26	46	—	34	29	1.3	58,800	
1390 1※207090	-PHC07A -90	1	7	90	30	26	28	46	—	34	29	—	58,800	
1390 1※208090	-PHC08A -90	1	8	90	30	26	28	46	—	34	29	—	58,800	
1390 1※209105	-PHC09A -105	1	9	105	44	28	30	52	—	50	40	1.5	56,400	
1390 1※210105	-PHC10A -105	1	10	105	44	28	30	52	—	50	40	1.5	56,400	
1390 1※211105	-PHC11A -105	1	11	105	45	30	32	52	—	50	40	—	56,400	
1390 1※212105	-PHC12A -105	1	12	105	45	30	32	52	—	50	40	1.5	59,400	
1390 1※213105	-PHC13A -105	1	13	105	46	34	36	52	—	50	40	—	56,400	
1390 1※214105	-PHC14A -105	1	14	105	46	34	36	52	—	50	40	1.5	56,400	
1390 1※215105	-PHC15A -105	1	15	105	46	36	38	52	—	50	40	—	56,400	
1390 1※216105	-PHC16A -105	1	16	105	46	36	38	52	—	50	40	1.6	56,400	
1390 1※220105	-PHC20A -105	1	20	105	49	40	42	46	—	50	40	1.5	59,400	
1390 1※225120	-PHC25A -120	1	25	120	59	50	52	59	—	60	50	2.1	58,500	L-6T

商品コードの※は低圧用では0、高圧用では1となります。

- 刃具シャンク部が下記公差範囲内の刃物を使用して下さい。
刃具シャンク径がφ6未満・・・h6公差範囲内
刃具シャンク径がφ6以上・・・h7公差範囲内
新規に刃物を製作される場合は、h6公差または $0_{-0.01}$ 公差で製作されることをお勧めします。
 - ホルダを空締めしたまま放置しないでください。
 - PHC12A、PHC20Aにはスリップ防止ピン付コレット装着用の穴が開いています。
 - UTS5040は高圧用のみになります。
- Cutting tool shank must be within tolerances specified below ;
Shank diameter less than 6mm : Within h6 tolerance
Shank diameter 6mm and over : Within h7 tolerance
h6 or 0/-0.01 tolerance is recommended when newly making a cutting tool.
 - Do not leave the holder with actuating screw tightened when the chuck is empty.
 - PHC12A and PHC20A have pin holes for collet with stopper pin on its body.
 - Only high pressure type is available for UTS5040.

ご注文例 Ordering Example

低圧用 Low pressure type
0 ~ 1.0MPa

UTS6350 - PHC12A- 105

シャンクサイズ 内径 (d) 突き出し長さ (L)
Shank size I.D. Pojection length

ご注文例 Ordering Example

高圧用 High pressure type
1.1 ~ 7.0MPa

UTS6350 - PHC12A- 105 - H

シャンクサイズ 内径 (d) 突き出し長さ (L) 高圧の場合
Shank size I.D. Pojection length High pressure type

PHS コレット
PHS Collet

P.105

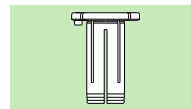

レンチ
Hex. wrench

P. 89



BT
AHO
HSK/AE/F/C
HSK-T
UTS
専用機
関連機器
サブメトリ
ミリングチャック
コレットホルダ
Rゼロホルダ
ハイドロチャック
タッピングチャック
アパー類