

# FH-ST-HDC-A New

Collet Type Floating Holder

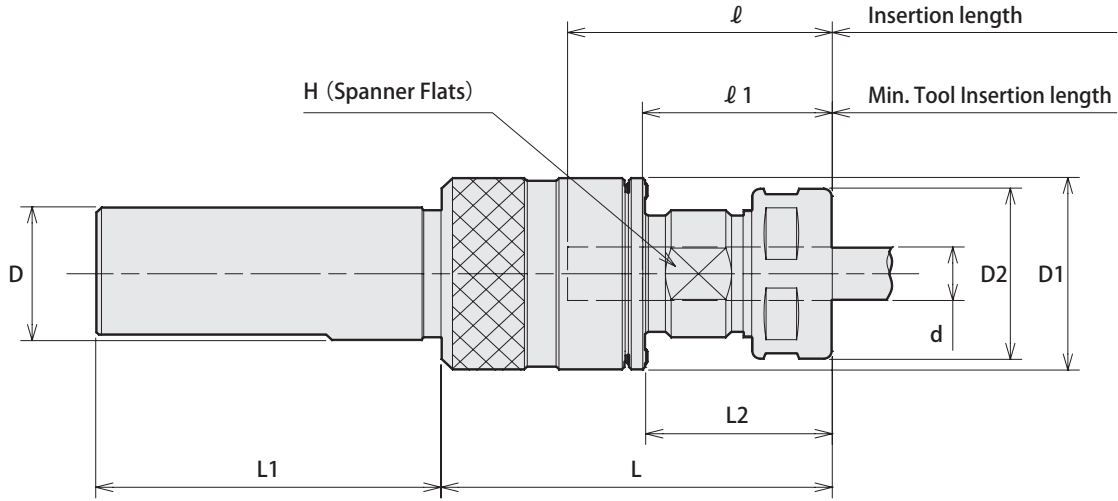

Code	Model	d	Float		D	D1	L	L1	l	l1	L2	D2	H	kg	Collet	Spanner	Adjustable pin wrench
			Radial	Angular													
0180 10001407	FH0 -ST25 -HDC07A	0.5 ~ 7.0	0.4	1°	25	28	62	60	35	22	27	23	17	0.1	FDC-07	S-0	—
0180 10011412	FH1 -ST25 -HDC12A	2.5 ~ 12.0	0 ~ 0.4	0 ~ 1° Adjustable	25	36	68	60	46	33	32	32	22	0.2	FDC-12	S-3L	GWA1
0180 10021422	FH2 -ST25 -HDC22A	3.5 ~ 22.0	0 ~ 0.6	0 ~ 1° Adjustable	25	55	95	60	68	47	44	46	35	0.5	FDC-22	S-5L	

1. For center through coolant feed, please contact NT TOOL beforehand for cutting conditions.
2. Collet and spanner are sold separately.
3. See P.499 for standard tightening torque.
4. For FH0, floating amount and angle are fixed.
5. To adjust floating amount, please use adjustable pin wrench (P.465)

<p>Adjustable pin wrench P. 465</p> 	<p>Collet P. 086 - 089</p> 	<p>Spanner P. 095</p> 
---	--	---

## Ordering Example

**FH0 - ST25 - HDC 07 A**  
Shank size    Max. collet I.D.