

"R"Zero Holder For Small Diameters

- Runout accuracy of the cutting edge can be adjusted as closely as to zero.
- For drilling in tight space.

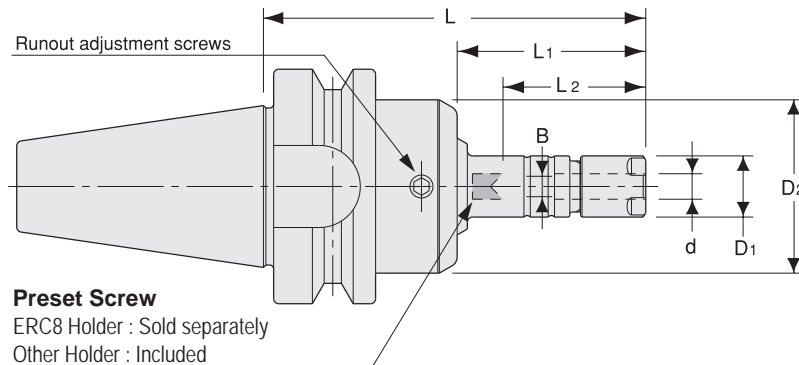

Unit : Metric

Code	Model	d	L	L1	B	L2	D1	D2	Nut	Collet	Spanner	Hex. Wrench
3130 00108060	BT30 -ERZ8 -60	0.5~5.0	60	22	— (0 ~ 3.1)	³³ (19 ~ 29)	12	34	ERP-8	ER8 sold separately	S-8E	L-3T
3130 00108075	-75	0.5~5.0	75	37	— (0 ~ 3.1)	³³ (19 ~ 29)	12	34	ERP-8			
3130 00108090	-90	0.5~5.0	90	52	— (0 ~ 3.1)	³³ (19 ~ 29)	12	34	ERP-8			
3130 00108105	-105	0.5~5.0	105	67	— (0 ~ 3.1)	³³ (19 ~ 29)	12	34	ERP-8			
3130 00110060	BT30 -ERZ11S -60	0.5~7.0	60	22	0 ~ 4	22 ~ 42	16	34	ERP-11S	ER11	S-11E	L-3T
3130 00110075	-75	0.5~7.0	75	37	0 ~ 4	22 ~ 42	16	34	ERP-11S			
3130 00110090	-90	0.5~7.0	90	52	0 ~ 4	22 ~ 42	16	34	ERP-11S			
3130 00110105	-105	0.5~7.0	105	67	0 ~ 4	22 ~ 42	16	34	ERP-11S			
3130 00308075	BT40 -ERZ8 -75	0.5~5.0	75	32	— (0 ~ 3.1)	³³ (19 ~ 29)	12	34	ERP-8	ER8 sold separately	S-8E	L-3T
3130 00308090	-90	0.5~5.0	90	47	— (0 ~ 3.1)	³³ (19 ~ 29)	12	34	ERP-8			
3130 00308105	-105	0.5~5.0	105	62	— (0 ~ 3.1)	³³ (19 ~ 29)	12	34	ERP-8			
3130 00308135	-135	0.5~5.0	135	92	— (0 ~ 3.1)	³³ (19 ~ 29)	12	34	ERP-8			
3130 00310075	BT40 -ERZ11S -75	0.5~7.0	75	32	0 ~ 4	22 ~ 42	16	34	ERP-11S	ER11	S-11E	L-3T
3130 00310090	-90	0.5~7.0	90	47	0 ~ 4	22 ~ 42	16	34	ERP-11S			
3130 00310105	-105	0.5~7.0	105	62	0 ~ 4	22 ~ 42	16	34	ERP-11S			
3130 00310135	-135	0.5~7.0	135	92	0 ~ 4	22 ~ 42	16	34	ERP-11S			

1. Collet ,spanner and hex. wrench are sold separately.
2. ES8, a preset screw for ERZ8, is sold separately. ERZ11S includes a standard preset screw HDS-07A-ES11.
3. " B " and " L2 " dimensions in brackets are for using ES8 preset screw.
4. Refer to P. 92 for minimum tool insertion length in case of using our coolant collets.
5. See P.499 for standard Tightening Torque.

Collet

P. 090-091



Spanner

P. 095



Preset screw

P. 094



Hex. Wrench

P. 095



Ordering Example

BT40 - ERZ 8 - 105
 Shank size Max. Projection
 collet I.D. length (L)

ERZ

"R"Zero Holder For Small Diameters

- Holder with runout adjustment mechanism. Suitable for drilling in tight space.

Preset Screw

ERC8 Holder : Sold separately
Other Holder : Included

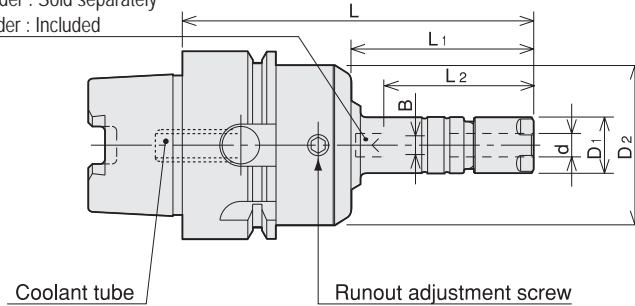

- Coolant tube is included.

Unit : Metric

Code	Model	d	L	L1	B	L2	D1	D2	Nut	Collet	Spanner	Wrench
5680 00308075	HSK40A -ERZ8 -75	0.5 ~ 5.0	75	39	— (0 ~ 3.1)	³³ (19 ~ 29)	12	34	ERP-8			
5680 00308090	-90	0.5 ~ 5.0	90	54	— (0 ~ 3.1)	³³ (19 ~ 29)	12	34	ERP-8	ER8	S-8E	L-3T
5680 00308105	-105	0.5 ~ 5.0	105	69	— (0 ~ 3.1)	³³ (19 ~ 29)	12	34	ERP-8			
5680 00310075	HSK40A-ERZ11S-75	0.5 ~ 7.0	75	39	0 ~ 4	22 ~ 35	16	34	ERP-11S			
5680 00310090	-90	0.5 ~ 7.0	90	54	0 ~ 4	22 ~ 42	16	34	ERP-11S	FDC-07	S-11E	L-3T
5680 00310105	-105	0.5 ~ 7.0	105	69	0 ~ 4	22 ~ 42	16	34	ERP-11S			
5680 00408075	HSK50A -ERZ8 -75	0.5 ~ 5.0	75	33	— (0 ~ 3.1)	³³ (19 ~ 28)	12	34	ERP-8			
5680 00408090	-90	0.5 ~ 5.0	90	48	— (0 ~ 3.1)	³³ (19 ~ 29)	12	34	ERP-8	ER8	S-8E	L-3T
5680 00408105	-105	0.5 ~ 5.0	105	63	— (0 ~ 3.1)	³³ (19 ~ 29)	12	34	ERP-8			
5680 00410075	HSK50A-ERZ11S-75	0.5 ~ 7.0	75	33	0 ~ 4	22 ~ 29	16	34	ERP-11S			
5680 00410090	-90	0.5 ~ 7.0	90	48	0 ~ 4	22 ~ 42	16	34	ERP-11S	FDC-07	S-11E	L-3T
5680 00410105	-105	0.5 ~ 7.0	105	63	0 ~ 4	22 ~ 42	16	34	ERP-11S			
5680 00508075	HSK63A -ERZ8 -75	0.5 ~ 5.0	75	33	— (0 ~ 3.1)	³³ (19 ~ 26)	12	34	ERP-8			
5680 00508090	-90	0.5 ~ 5.0	90	48	— (0 ~ 3.1)	³³ (19 ~ 29)	12	34	ERP-8	ER8	S-8E	L-3T
5680 00508120	-120	0.5 ~ 5.0	120	78	— (0 ~ 3.1)	³³ (19 ~ 29)	12	34	ERP-8			
5680 00510075	HSK63A-ERZ11S-75	0.5 ~ 7.0	75	33	0 ~ 4	22 ~ 32	16	34	ERP-11S			
5680 00510090	-90	0.5 ~ 7.0	90	48	0 ~ 4	22 ~ 42	16	34	ERP-11S	FDC-07	S-11E	L-3T
5680 00510120	-120	0.5 ~ 7.0	120	78	0 ~ 4	22 ~ 42	16	34	ERP-11S			

1. Collet, spanner and adjustment wrench are sold separately.
2. ES8, a preset screw for ERZ8, is sold separately. ERZ11S includes a standard preset screw HDS-07A-ES11.
3. "B" and "L2" dimensions in brackets are for using ES8 preset screw.
4. Refer to P.092 for minimum tool insertion length in case of using our coolant collets.
5. See P.499 for standard Tightening Torque.

Collet P. 090-091	Spanner P. 095	Preset screw P. 094	Adjustment wrench P. 095

Ordering Example

HSK63A - ERZ 8 - 75
Shank size Max. collet I.D. Projection length (L)

"R"Zero Holder For Small Diameters

- Holder with runout adjustment mechanism. Suitable for drilling in tight space.

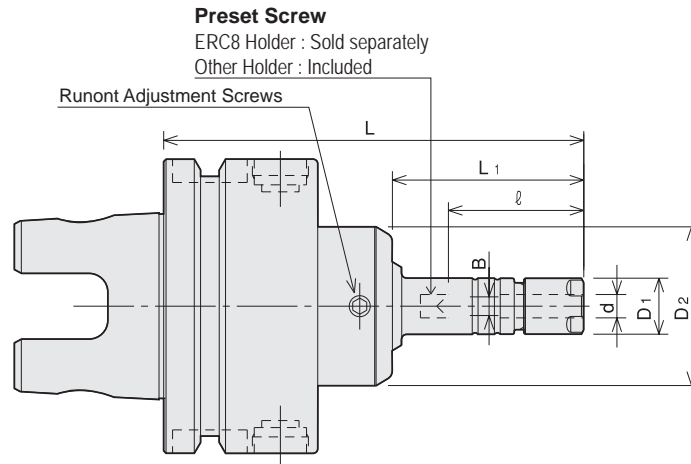

Unit : Metric

Code	Model	d	L	L1	B	l	D1	D2	Nut	Collet	Spanner	Wrench
1350 01108075	UTS5040 -ERZ8 -75H	0.5 ~ 5.0	75	29	— (0 ~ 3.1)	³³ (19 ~ 22)	12	34	ERP-8			
1350 01108090	-90H	0.5 ~ 5.0	90	44	— (0 ~ 3.1)	³³ (19 ~ 29)	12	34	ERP-8	ER8	S-8E	L-3T
1350 01108105	-105H	0.5 ~ 5.0	105	59	— (0 ~ 3.1)	³³ (19 ~ 29)	12	34	ERP-8			
1350 01110075	UTS5040 -ERZ11S -75H	0.5 ~ 7.0	75	29	0 ~ 4	22 ~ 29	16	34	ERP-11S			
1350 01110090	-90H	0.5 ~ 7.0	90	44	0 ~ 4	22 ~ 42	16	34	ERP-11S	ER11	S-11E	L-3T
1350 01110105	-105H	0.5 ~ 7.0	105	59	0 ~ 4	22 ~ 42	16	34	ERP-11S			
1350 0 ※ 208075	UTS6350 -ERZ8 -75	0.5 ~ 5.0	75	26	— (0 ~ 3.1)	³³ (19 ~ 22)	12	34	ERP-8			
1350 0 ※ 208090	-90	0.5 ~ 5.0	90	41	— (0 ~ 3.1)	³³ (19 ~ 29)	12	34	ERP-8	ER8	S-8E	L-3T
1350 0 ※ 208120	-120	0.5 ~ 5.0	120	71	— (0 ~ 3.1)	³³ (19 ~ 29)	12	34	ERP-8			
1350 0 ※ 210075	UTS6350 -ERZ11S -75	0.5 ~ 7.0	75	26	0 ~ 4	22 ~ 31	16	34	ERP-11S			
1350 0 ※ 210090	-90	0.5 ~ 7.0	90	41	0 ~ 4	22 ~ 42	16	34	ERP-11S	ER11	S-11E	L-3T
1350 0 ※ 210120	-120	0.5 ~ 7.0	120	71	0 ~ 4	22 ~ 42	16	34	ERP-11S			

When placing an order, please specify high or low pressure. For high pressure type, please add (-H) on end of the description.

1. Collet, spanner and adjustment wrench are sold separately.
2. ES8, a preset screw for ERZ8, is sold separately.
ERZ11S includes a standard preset screw HDS-07A-ES11.
3. "B" and "l" dimensions in brackets are for using ES8 preset screw.
4. Refer to P.092 for minimum tool insertion length in case of using our coolant collets.
5. UTS5040 is available in high pressure only.

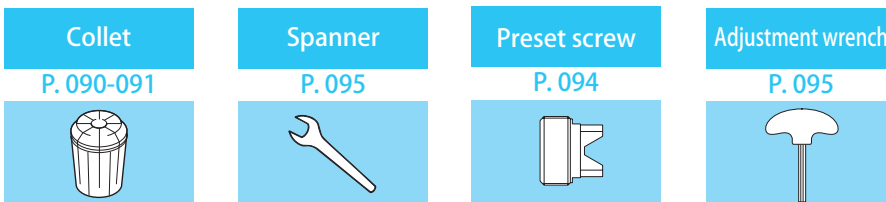

Ordering Example

Low pressure type

0 ~ 1.0MPa (UTS10080 : 0 ~ 2.0MPa)

UTS6350 - ERZ 8 - 75
Shank size Max. collet I.D. Projection length (L)

Ordering Example

High pressure type

1.1 ~ 7.0MPa (UTS10080 : 2.1 ~ 7.0MPa)

UTS6350 - ERZ 8 - 75 - H
Shank size Max. collet I.D. Projection length (L) High pressure type