

"R"Zero Holder (High-Balanced Type)

- Runout accuracy of the cutting edge can be adjusted as closely as to zero. (High balanced type for higher RPM)

Type1

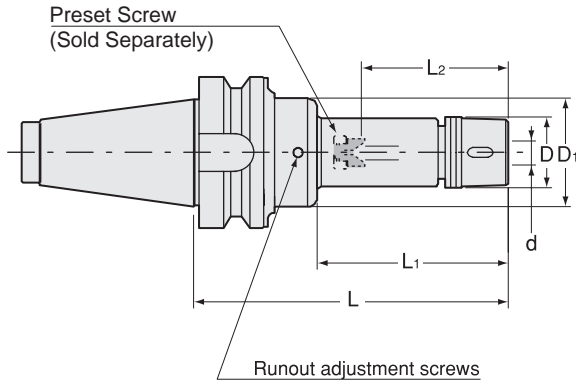

Type2

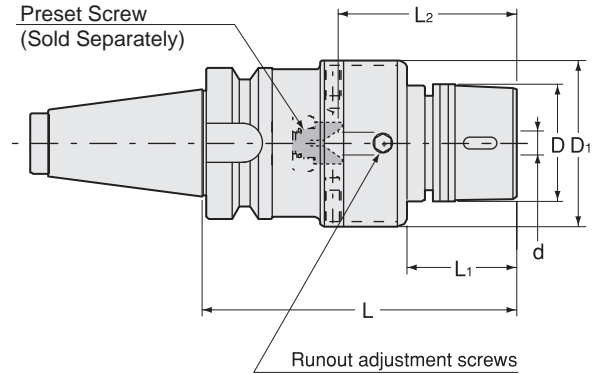

Unit : Metric

Code	Model	Type	d	L	L1	L2	D	D1	Nut	kg	Collet	Spanner	Hex. Wrench
3120 00107060	BT30 -GDZ07 -60	1	0.5 ~ 7.0	60	22	22 ~ 45	23	41	HDP-07A	0.6	FDC-07AA	S-0	L-3T
3120 00107075	-75	1	0.5 ~ 7.0	75	37	22 ~ 45	23	41	HDP-07A	0.6			
3120 00107090	-90	1	0.5 ~ 7.0	90	52	22 ~ 45	23	41	HDP-07A				
3120 00107105	-105	1	0.5 ~ 7.0	105	67	22 ~ 45	23	41	HDP-07A	0.7			
3120 00109075	BT30 -GDZ09 -75	1	2.5 ~ 9.0	75	28	27 ~ 57	29	41	GDP-09	0.7	FDC-09AA	FK-0025	L-3T
3120 00109090	-90	1	2.5 ~ 9.0	90	43	27 ~ 57	29	41	GDP-09				
3120 00109105	-105	1	2.5 ~ 9.0	105	58	27 ~ 57	29	41	GDP-09				
3120 00112105	BT30 -GDZ12 -105	2	2.5 ~ 12.0	105	42	33 ~ 69	34	52	GDP-12	1.1	FDC-12AA	FK-0034	L-4T
3120 00112120	-120	2	2.5 ~ 12.0	120	57	33 ~ 69	34	52	GDP-12				
3120 00112135	-135	2	2.5 ~ 12.0	135	72	33 ~ 69	34	52	GDP-12				
3120 00116105	BT30 -GDZ16 -105	2	3.5 ~ 16.0	105	42	38 ~ 82	38	56	GDP-16	1.2	FDC-16AA	FK-0034	L-4T
3120 00116120	-120	2	3.5 ~ 16.0	120	57	38 ~ 82	38	56	GDP-16				
3120 00116135	-135	2	3.5 ~ 16.0	135	72	38 ~ 82	38	56	GDP-16				
3120 00307090	BT40 -GDZ07 -90	1	0.5 ~ 7.0	90	43	22 ~ 45	23	41	HDP-07A	1.3	FDC-07AA	S-0	L-3T
3120 00307105	-105	1	0.5 ~ 7.0	105	58	22 ~ 45	23	41	HDP-07A				
3120 00307120	-120	1	0.5 ~ 7.0	120	73	22 ~ 45	23	41	HDP-07A				
3120 00309090	BT40 -GDZ09 -90	1	2.5 ~ 9.0	90	43	27 ~ 57	29	45	GDP-09	1.3	FDC-09AA	FK-0025	L-3T
3120 00309105	-105	1	2.5 ~ 9.0	105	58	27 ~ 57	29	45	GDP-09	1.4			
3120 00309120	-120	1	2.5 ~ 9.0	120	73	27 ~ 57	29	45	GDP-09				
3120 00309135	-135	1	2.5 ~ 9.0	135	88	27 ~ 57	29	45	GDP-09				
3120 00309165	-165	1	2.5 ~ 9.0	165	118	27 ~ 57	29	45	GDP-09				
3120 00312090	BT40 -GDZ12 -90	1	2.5 ~ 12.0	90	39	33 ~ 69	34	56	GDP-12	1.5	FDC-12AA	FK-0034	L-4T
3120 00312105	-105	1	2.5 ~ 12.0	105	54	33 ~ 69	34	56	GDP-12	1.6			
3120 00312120	-120	1	2.5 ~ 12.0	120	69	33 ~ 69	34	56	GDP-12	1.7			
3120 00312135	-135	1	2.5 ~ 12.0	135	84	33 ~ 69	34	56	GDP-12				
3120 00312165	-165	1	2.5 ~ 12.0	165	114	33 ~ 69	34	56	GDP-12				
3120 00312195	-195	1	2.5 ~ 12.0	195	144	33 ~ 69	34	56	GDP-12				
3120 00316090	BT40 -GDZ16 -90	1	3.5 ~ 16.0	90	43	38 ~ 82	38	62	GDP-16	1.6	FDC-16AA	FK-0034	L-4T
3120 00316105	-105	1	3.5 ~ 16.0	105	58	38 ~ 82	38	62	GDP-16	1.7			
3120 00316120	-120	1	3.5 ~ 16.0	120	73	38 ~ 82	38	62	GDP-16				
3120 00316135	-135	1	3.5 ~ 16.0	135	88	38 ~ 82	38	62	GDP-16				
3120 00316165	-165	1	3.5 ~ 16.0	165	118	38 ~ 82	38	62	GDP-16				
3120 00316195	-195	1	3.5 ~ 16.0	195	148	38 ~ 82	38	62	GDP-16				
3120 00322120	BT40 -GDZ22 -120	2	3.5 ~ 22.0	120	40	47 ~ 103	49	69	GDP-22	2.4			
3120 00322135	-135	2	3.5 ~ 22.0	135	55	47 ~ 103	49	69	GDP-22	2.6			
3120 00322165	-165	2	3.5 ~ 22.0	165	85	47 ~ 103	49	69	GDP-22				
3120 00322195	-195	2	3.5 ~ 22.0	195	115	47 ~ 103	49	69	GDP-22				

Metric Sizes

Unit : Metric

Code	Model	Type	d	L	L1	L2	D	D1	Nut	kg	Collet	Spanner	Hex. Wrench
3120 00507090	BT50 -GDZ07 -90	1	0.5 ~ 7.0	90	32	22 ~ 45	23	41	HDP-07A		FDC-07AA	S-0	L-3T
3120 00507105	-105	1	0.5 ~ 7.0	105	47	22 ~ 45	23	41	HDP-07A	3.8			
3120 00507120	-120	1	0.5 ~ 7.0	120	62	22 ~ 45	23	41	HDP-07A				
3120 00507135	-135	1	0.5 ~ 7.0	135	77	22 ~ 45	23	41	HDP-07A				
3120 00507165	-165	1	0.5 ~ 7.0	165	107	22 ~ 45	23	41	HDP-07A				
3120 00507195	-195	1	0.5 ~ 7.0	195	137	22 ~ 45	23	41	HDP-07A				
3120 00509090	BT50 -GDZ09 -90	1	2.5 ~ 9.0	90	32	27 ~ 57	29	45	GDP-09		FDC-09AA	FK-0025	L-3T
3120 00509105	-105	1	2.5 ~ 9.0	105	47	27 ~ 57	29	45	GDP-09				
3120 00509120	-120	1	2.5 ~ 9.0	120	62	27 ~ 57	29	45	GDP-09				
3120 00509135	-135	1	2.5 ~ 9.0	135	77	27 ~ 57	29	45	GDP-09				
3120 00509165	-165	1	2.5 ~ 9.0	165	107	27 ~ 57	29	45	GDP-09				
3120 00509195	-195	1	2.5 ~ 9.0	195	137	27 ~ 57	29	45	GDP-09				
3120 00509225	-225	1	2.5 ~ 9.0	225	167	27 ~ 57	29	45	GDP-09				
3120 00509255	-255	1	2.5 ~ 9.0	255	197	27 ~ 57	29	45	GDP-09				
3120 00512105	BT50 -GDZ12 -105	1	2.5 ~ 12.0	105	43	33 ~ 69	34	56	GDP-12		FDC-12AA	FK-0034	L-4T
3120 00512120	-120	1	2.5 ~ 12.0	120	58	33 ~ 69	34	56	GDP-12				
3120 00512135	-135	1	2.5 ~ 12.0	135	73	33 ~ 69	34	56	GDP-12				
3120 00512165	-165	1	2.5 ~ 12.0	165	103	33 ~ 69	34	56	GDP-12				
3120 00512195	-195	1	2.5 ~ 12.0	195	133	33 ~ 69	34	56	GDP-12				
3120 00512225	-225	1	2.5 ~ 12.0	225	163	33 ~ 69	34	56	GDP-12				
3120 00512255	-255	1	2.5 ~ 12.0	255	193	33 ~ 69	34	56	GDP-12				
3120 00516105	BT50 -GDZ16 -105	1	3.5 ~ 16.0	105	43	38 ~ 82	38	62	GDP-16		FDC-16AA	FK-0034	L-4T
3120 00516120	-120	1	3.5 ~ 16.0	120	58	38 ~ 82	38	62	GDP-16				
3120 00516135	-135	1	3.5 ~ 16.0	135	73	38 ~ 82	38	62	GDP-16	4.4			
3120 00516165	-165	1	3.5 ~ 16.0	165	103	38 ~ 82	38	62	GDP-16				
3120 00516195	-195	1	3.5 ~ 16.0	195	133	38 ~ 82	38	62	GDP-16				
3120 00516225	-225	1	3.5 ~ 16.0	225	163	38 ~ 82	38	62	GDP-16				
3120 00516255	-255	1	3.5 ~ 16.0	255	193	38 ~ 82	38	62	GDP-16				
3120 00522105	BT50 -GDZ22 -105	1	3.5 ~ 22.0	105	39	47 ~ 103	49	76	GDP-22	4.5	FDC-22AA	FK-0045	L-5T
3120 00522120	-120	1	3.5 ~ 22.0	120	54	47 ~ 103	49	76	GDP-22				
3120 00522135	-135	1	3.5 ~ 22.0	135	69	47 ~ 103	49	76	GDP-22				
3120 00522150	-150	1	3.5 ~ 22.0	150	84	47 ~ 103	49	76	GDP-22				
3120 00522165	-165	1	3.5 ~ 22.0	165	99	47 ~ 103	49	76	GDP-22	5.2			
3120 00522195	-195	1	3.5 ~ 22.0	195	129	47 ~ 103	49	76	GDP-22	5.6			
3120 00522225	-225	1	3.5 ~ 22.0	225	159	47 ~ 103	49	76	GDP-22				
3120 00522255	-255	1	3.5 ~ 22.0	255	189	47 ~ 103	49	76	GDP-22				

1. Collet, preset screw, spanner and hex. wrench are sold separately.
2. Always use AA class collet.
3. Refer to P. 092 for minimum tool insertion length in case of using our coolant collets (OH,C or MS).
4. L2 indicates dimension when using with a preset screw.
5. See P.499 for standard Tightening Torque.

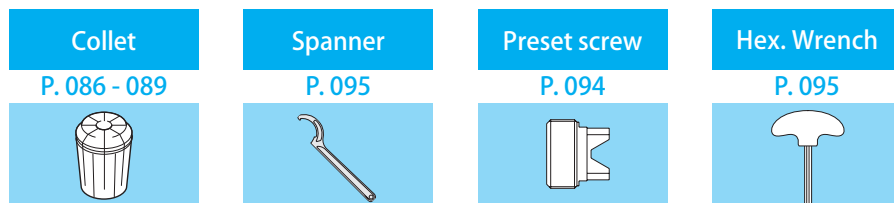

Ordering Example

BT40 - GDZ 09 - 90

Shank size Max. collet I.D. Projection length (L)

"R"Zero Holder (High-Balanced Type)

- Runout accuracy of the cutting edge can be adjusted as closely as to zero. (High-balanced type)

Type1

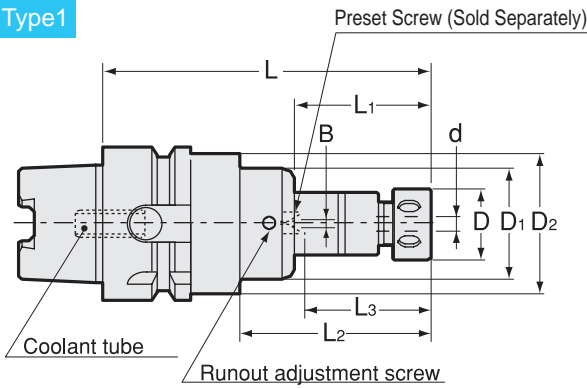

Type2

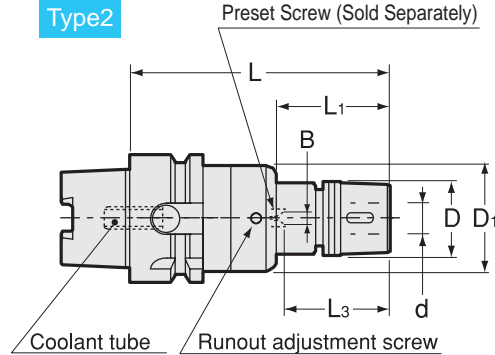

Type3

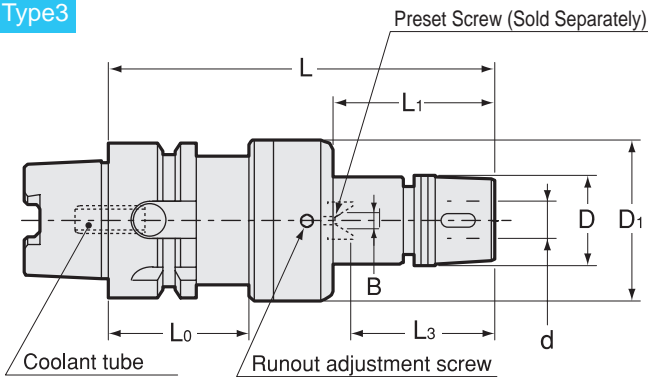

- Coolant tube is included.

Unit : Metric

Code	Model	Type	d	L	L1	L2	L3	D	D1	D2	L0	Nut	kg	Collet	Spanner	Wrench
5670 13007075	HSK40A -GDZ07 -75	2	0.5 ~ 7.0	75	30	-	22 ~ 30	23	34	-	-	HDP-07A		FDC-07AA	S-0	L-3T
5670 13007090	-90	2	0.5 ~ 7.0	90	45	-	22 ~ 45	23	34	-	-	HDP-07A	0.5	FDC-07AA	S-0	L-3T
5670 13007120	-120	2	0.5 ~ 7.0	120	75	-	22 ~ 45	23	34	-	-	HDP-07A		FDC-07AA	S-0	L-3T
5670 13009090	HSK40A -GDZ09 -90	3	2.5 ~ 9.0	90	28	-	27 ~ 42	29	41	-	35	GDP-09		FDC-09AA	FK-0025	L-3T
5670 13009120	-120	3	2.5 ~ 9.0	120	58	-	27 ~ 57	29	41	-	35	GDP-09		FDC-09AA	FK-0025	L-3T
5670 13009135	-135	3	2.5 ~ 9.0	135	73	-	27 ~ 57	29	41	-	35	GDP-09		FDC-09AA	FK-0025	L-3T
5670 13012105	HSK40A -GDZ12 -105	3	2.5 ~ 12.0	105	39	-	33 ~ 54	34	52	-	35	GDP-12		FDC-12AA	FK-0034	L-4T
5670 13012120	-120	3	2.5 ~ 12.0	120	54	-	33 ~ 69	34	52	-	35	GDP-12		FDC-12AA	FK-0034	L-4T
5670 13012150	-150	3	2.5 ~ 12.0	150	84	-	33 ~ 69	34	52	-	35	GDP-12		FDC-12AA	FK-0034	L-4T
5670 13016105	HSK40A -GDZ16 -105	3	3.5 ~ 16.0	105	39	-	38 ~ 57	38	56	-	35	GDP-16		FDC-16AA	FK-0034	L-4T
5670 13016120	-120	3	3.5 ~ 16.0	120	54	-	38 ~ 72	38	56	-	35	GDP-16		FDC-16AA	FK-0034	L-4T
5670 13016150	-150	3	3.5 ~ 16.0	150	84	-	38 ~ 82	38	56	-	35	GDP-16		FDC-16AA	FK-0034	L-4T
5670 14007090	HSK50A -GDZ07 -90	2	0.5 ~ 7.0	90	39	-	22 ~ 45	23	41	-	-	HDP-07A		FDC-07AA	S-0	L-3T
5670 14007120	-120	2	0.5 ~ 7.0	120	69	-	22 ~ 45	23	41	-	-	HDP-07A		FDC-07AA	S-0	L-3T
5670 14007135	-135	2	0.5 ~ 7.0	135	84	-	22 ~ 45	23	41	-	-	HDP-07A		FDC-07AA	S-0	L-3T
5670 14009090	HSK50A -GDZ09 -90	2	2.5 ~ 9.0	90	39	-	27 ~ 46	29	41	-	-	GDP-09		FDC-09AA	FK-0025	L-3T
5670 14009120	-120	2	2.5 ~ 9.0	120	69	-	27 ~ 57	29	41	-	-	GDP-09		FDC-09AA	FK-0025	L-3T
5670 14009135	-135	2	2.5 ~ 9.0	135	84	-	27 ~ 57	29	41	-	-	GDP-09		FDC-09AA	FK-0025	L-3T
5670 14012105	HSK50A -GDZ12 -105	3	2.5 ~ 12.0	105	32	-	33 ~ 58	34	52	-	42	GDP-12		FDC-12AA	FK-0034	L-4T
5670 14012120	-120	3	2.5 ~ 12.0	120	47	-	33 ~ 69	34	52	-	42	GDP-12		FDC-12AA	FK-0034	L-4T
5670 14012150	-150	3	2.5 ~ 12.0	150	77	-	33 ~ 69	34	52	-	42	GDP-12		FDC-12AA	FK-0034	L-4T
5670 14016105	HSK50A -GDZ16 -105	3	3.5 ~ 16.0	105	32	-	38 ~ 53	38	56	-	42	GDP-16		FDC-16AA	FK-0034	L-4T
5670 14016120	-120	3	3.5 ~ 16.0	120	47	-	38 ~ 68	38	56	-	42	GDP-16		FDC-16AA	FK-0034	L-4T
5670 14016150	-150	3	3.5 ~ 16.0	150	77	-	38 ~ 82	38	56	-	42	GDP-16		FDC-16AA	FK-0034	L-4T

Code	Model	Type	d	L	L1	L2	L3	D	D1	D2	L0	Nut	kg	Collet	Spanner	Wrench
5670 15007090	HSK63A -GDZ07 -90	1	0.5 ~ 7.0	90	33	49	22 ~ 45	23	41	52	—	HDP-07A	1.1	FDC-07AA	S-0	L-3T
5670 15007120	-120	1	0.5 ~ 7.0	120	63	79	22 ~ 45	23	41	52	—	HDP-07A	1.2			
5670 15007135	-135	1	0.5 ~ 7.0	135	78	94	22 ~ 45	23	41	52	—	HDP-07A				
5670 15009090	HSK63A -GDZ09 -90	1	2.5 ~ 9.0	90	33	49	27 ~ 42	29	45	52	—	GDP-09	1.2	FDC-09AA	FK-0025	L-3T
5670 15009120	-120	1	2.5 ~ 9.0	120	63	79	27 ~ 57	29	45	52	—	GDP-09	1.3			
5670 15009135	-135	1	2.5 ~ 9.0	135	78	94	27 ~ 57	29	45	52	—	GDP-09	1.4			
5670 15012105	HSK63A -GDZ12 -105	2	2.5 ~ 12.0	105	50	—	33 ~ 54	34	52	—	—	GDP-12	1.3	FDC-12AA	FK-0034	L-4T
5670 15012120	-120	2	2.5 ~ 12.0	120	65	—	33 ~ 69	34	52	—	—	GDP-12				
5670 15012150	-150	2	2.5 ~ 12.0	150	95	—	33 ~ 69	34	52	—	—	GDP-12				
5670 15016105	HSK63A -GDZ16 -105	3	3.5 ~ 16.0	105	32	—	38 ~ 57	38	56	—	42	GDP-16	1.6	FDC-16AA	FK-0034	L-4T
5670 15016120	-120	3	3.5 ~ 16.0	120	47	—	38 ~ 67	38	56	—	42	GDP-16	1.7			
5670 15016150	-150	3	3.5 ~ 16.0	150	77	—	38 ~ 82	38	56	—	42	GDP-16				
5670 15022120	HSK63A -GDZ22 -120	3	3.5 ~ 22.0	120	43	—	47 ~ 63	49	69	—	42	GDP-22	2.1	FDC-22AA	FK-0045	L-5T
5670 15022150	-150	3	3.5 ~ 22.0	150	73	—	47 ~ 93	49	69	—	42	GDP-22				
5670 17007090	HSK100A -GDZ07 -90	1	0.5 ~ 7.0	90	30	46	22 ~ 45	23	41	84	—	HDP-07A		FDC-07AA	S-0	L-3T
5670 17007120	-120	1	0.5 ~ 7.0	120	60	76	22 ~ 45	23	41	84	—	HDP-07A				
5670 17007135	-135	1	0.5 ~ 7.0	135	75	91	22 ~ 45	23	41	84	—	HDP-07A				
5670 17009090	HSK100A -GDZ09 -90	1	2.5 ~ 9.0	90	30	46	27 ~ 45	29	45	84	—	GDP-09		FDC-09AA	FK-0025	L-3T
5670 17009120	-120	1	2.5 ~ 9.0	120	60	76	27 ~ 57	29	45	84	—	GDP-09				
5670 17009135	-135	1	2.5 ~ 9.0	135	75	91	27 ~ 57	29	45	84	—	GDP-09				
5670 17012105	HSK100A -GDZ12 -105	1	2.5 ~ 12.0	105	41	61	33 ~ 45	34	56	84	—	GDP-12		FDC-12AA	FK-0034	L-4T
5670 17012120	-120	1	2.5 ~ 12.0	120	56	76	33 ~ 60	34	56	84	—	GDP-12				
5670 17012150	-150	1	2.5 ~ 12.0	150	86	106	33 ~ 69	34	56	84	—	GDP-12				
5670 17016105	HSK100A -GDZ16 -105	1	3.5 ~ 16.0	105	41	61	38 ~ 47	38	62	84	—	GDP-16		FDC-16AA	FK-0034	L-4T
5670 17016120	-120	1	3.5 ~ 16.0	120	56	76	38 ~ 62	38	62	84	—	GDP-16				
5670 17016150	-150	1	3.5 ~ 16.0	150	86	106	38 ~ 82	38	62	84	—	GDP-16				
5670 17022105	HSK100A -GDZ22 -105	1	3.5 ~ 22.0	105	37	61	65	49	76	84	—	GDP-22		FDC-22AA	FK-0045	L-5T
5670 17022120	-120	1	3.5 ~ 22.0	120	52	76	47 ~ 57	49	76	84	—	GDP-22				
5670 17022150	-150	1	3.5 ~ 22.0	150	82	106	47 ~ 87	49	76	84	—	GDP-22				

1. Collet, preset screw, spanner and adjustment wrench are sold separately.
2. Always use AA class collet.
3. Refer to P.092 for minimum tool insertion length in case of using our coolant collets (OH,C or MS).
4. "L3" dimensions in brackets are for using preset screw.
5. See P.499 for standard Tightening Torque.

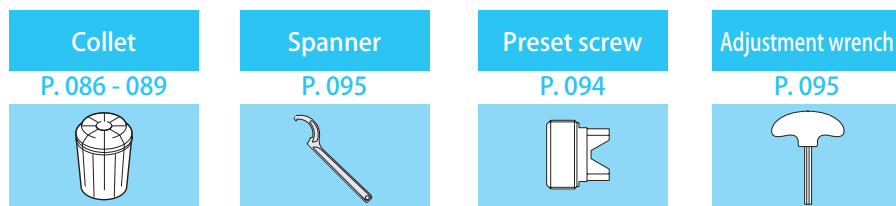

Ordering Example

HSK63A - GDZ 07 - 90

Shank size Max. collet I.D. Projection length (L)