

HDZ

"R"Zero Holder

- Runout accuracy of the cutting edge can be adjusted as closely as to zero.

Type1

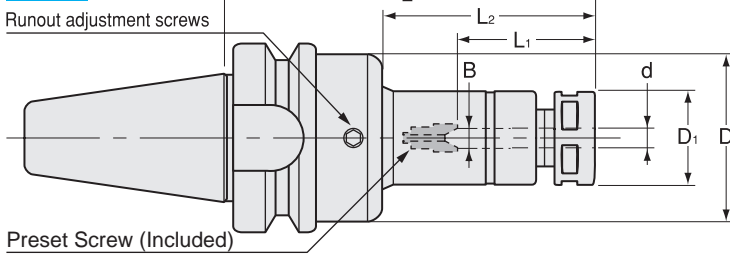

Type2

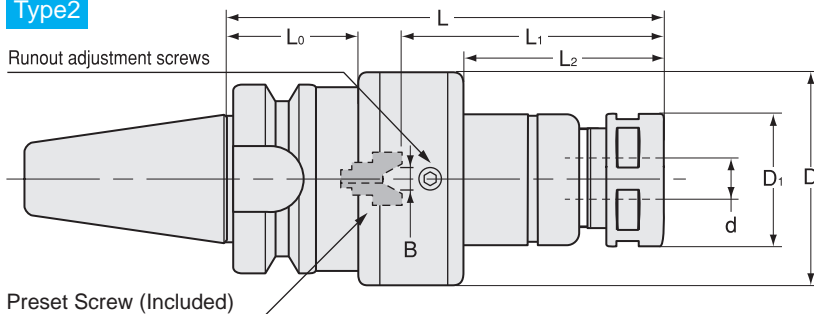

Unit : Metric

Code	Model	Type	d	L	L1	L2	B	D	D1	L0	Nut	kg	Collet	Spanner	Hex. Wrench
3090 10706000	BT30 -HDZ07 -60	1	0.5 ~ 7.0	60	22 ~ 45	22	0 ~ 4	41	23	—	HDP-07A	0.6	FDC-07	S-0	L-3T
3090 10707500	-75	1	0.5 ~ 7.0	75	22 ~ 45	37	0 ~ 4	41	23	—	HDP-07A	0.6			
3090 10709000	-90	1	0.5 ~ 7.0	90	22 ~ 45	52	0 ~ 4	41	23	—	HDP-07A	0.7			
3090 10710500	-105	1	0.5 ~ 7.0	105	22 ~ 45	67	0 ~ 4	41	23	—	HDP-07A	0.7			
3090 10907500	BT30 -HDZ09 -75	1	2.5 ~ 9.0	75	27 ~ 57	37	0 ~ 4	45	26	—	HDP-09	0.7	FDC-09	S-1L	L-3T
3090 10909000	-90	1	2.5 ~ 9.0	90	27 ~ 57	52	0 ~ 4	45	26	—	HDP-09	0.7			
3090 10910500	-105	1	2.5 ~ 9.0	105	27 ~ 57	67	0 ~ 4	45	26	—	HDP-09	0.7			
3090 11209000	BT30 -HDZ12 -90	2	2.5 ~ 12.0	90	33 ~ 69	33	0 ~ 5	52	32	32	HDP-12	1.0	FDC-12	S-3L	L-4T
3090 11210500	-105	2	2.5 ~ 12.0	105	33 ~ 69	48	0 ~ 5	52	32	32	HDP-12	1.1			
3090 11609000	BT30 -HDZ16 -90	2	3.5 ~ 16.0	90	38 ~ 82	33	0 ~ 6	56	36	32	HDP-16	1.0	FDC-16	S-4L	L-4T
3090 11610500	-105	2	3.5 ~ 16.0	105	38 ~ 82	48	0 ~ 6	56	36	32	HDP-16	1.1			
3090 11612000	-120	2	3.5 ~ 16.0	120	38 ~ 82	63	0 ~ 6	56	36	32	HDP-16	1.1			
3090 30707500	BT40 -HDZ07 -75	1	0.5 ~ 7.0	75	22 ~ 45	32	0 ~ 4	41	23	—	HDP-07A	1.2	FDC-07	S-0	L-3T
3090 30709000	-90	1	0.5 ~ 7.0	90	22 ~ 45	47	0 ~ 4	41	23	—	HDP-07A	1.2			
3090 30710500	-105	1	0.5 ~ 7.0	105	22 ~ 45	62	0 ~ 4	41	23	—	HDP-07A	1.2			
3090 30909000	BT40 -HDZ09 -90	1	2.5 ~ 9.0	90	27 ~ 57	47	0 ~ 4	45	26	—	HDP-09	1.3	FDC-09	S-1L	L-3T
3090 30910500	-105	1	2.5 ~ 9.0	105	27 ~ 57	62	0 ~ 4	45	26	—	HDP-09	1.3			
3090 30912000	-120	1	2.5 ~ 9.0	120	27 ~ 57	77	0 ~ 4	45	26	—	HDP-09	1.3			
3090 30913500	-135	1	2.5 ~ 9.0	135	27 ~ 57	92	0 ~ 4	45	26	—	HDP-09	1.3			
3090 30916500	-165	1	2.5 ~ 9.0	165	27 ~ 57	122	0 ~ 4	45	26	—	HDP-09	1.3			
3090 31209000	BT40 -HDZ12 -90	1	2.5 ~ 12.0	90	33 ~ 69	43	0 ~ 5	56	32	—	HDP-12	1.5	FDC-12	S-3L	L-4T
3090 31210500	-105	1	2.5 ~ 12.0	105	33 ~ 69	58	0 ~ 5	56	32	—	HDP-12	1.6			
3090 31212000	-120	1	2.5 ~ 12.0	120	33 ~ 69	73	0 ~ 5	56	32	—	HDP-12	1.6			
3090 31213500	-135	1	2.5 ~ 12.0	135	33 ~ 69	88	0 ~ 5	56	32	—	HDP-12	1.7			
3090 31216500	-165	1	2.5 ~ 12.0	165	33 ~ 69	118	0 ~ 5	56	32	—	HDP-12	1.7			
3090 31219500	-195	1	2.5 ~ 12.0	195	33 ~ 69	148	0 ~ 5	56	32	—	HDP-12	2.0			
3090 31609000	BT40 -HDZ16 -90	1	3.5 ~ 16.0	90	38 ~ 82	43	0 ~ 6	62	36	—	HDP-16	1.6	FDC-16	S-4L	L-4T
3090 31610500	-105	1	3.5 ~ 16.0	105	38 ~ 82	58	0 ~ 6	62	36	—	HDP-16	1.7			
3090 31612000	-120	1	3.5 ~ 16.0	120	38 ~ 82	73	0 ~ 6	62	36	—	HDP-16	1.8			
3090 31613500	-135	1	3.5 ~ 16.0	135	38 ~ 82	88	0 ~ 6	62	36	—	HDP-16	1.9			
3090 31616500	-165	1	3.5 ~ 16.0	165	38 ~ 82	118	0 ~ 6	62	36	—	HDP-16	2.1			
3090 31619500	-195	1	3.5 ~ 16.0	195	38 ~ 82	148	0 ~ 6	62	36	—	HDP-16	2.1			

Code	Model	Type	d	L	L1	L2	B	D	D1	L0	Nut	kg	Collet	Spanner	Hex. Wrench
3090 32210500	BT40 -HDZ22 -105	2	3.5 ~ 22.0	105	47 ~ 103	31	0 ~ 8	69	46	45	HDP-22	2.1	FDC-22	S-5L	L-5T
3090 32212000	-120	2	3.5 ~ 22.0	120	47 ~ 103	46	0 ~ 8	69	46	45	HDP-22	2.3			
3090 32213500	-135	2	3.5 ~ 22.0	135	47 ~ 103	61	0 ~ 8	69	46	45	HDP-22	2.5			
3090 32216500	-165	2	3.5 ~ 22.0	165	47 ~ 103	91	0 ~ 8	69	46	45	HDP-22	2.8			
3090 32219500	-195	2	3.5 ~ 22.0	195	47 ~ 103	121	0 ~ 8	69	46	45	HDP-22				
3090 50709000	BT50 -HDZ07 -90	1	0.5 ~ 7.0	90	22 ~ 45	36	0 ~ 4	41	23	—	HDP-07	3.8	FDC-07A	S-0	L-3T
3090 50710500	-105	1	0.5 ~ 7.0	105	22 ~ 45	51	0 ~ 4	41	23	—	HDP-07				
3090 50712000	-120	1	0.5 ~ 7.0	120	22 ~ 45	66	0 ~ 4	41	23	—	HDP-07				
3090 50713500	-135	1	0.5 ~ 7.0	135	22 ~ 45	81	0 ~ 4	41	23	—	HDP-07				
3090 50716500	-165	1	0.5 ~ 7.0	165	22 ~ 45	111	0 ~ 4	41	23	—	HDP-07				
3090 50719500	-195	1	0.5 ~ 7.0	195	22 ~ 45	141	0 ~ 4	41	23	—	HDP-07				
3090 50909000	BT50 -HDZ09 -90	1	2.5 ~ 9.0	90	27 ~ 57	36	0 ~ 4	45	26	—	HDP-09		FDC-09	S-1L	L-3T
3090 50910500	-105	1	2.5 ~ 9.0	105	27 ~ 57	51	0 ~ 4	45	26	—	HDP-09	3.8			
3090 50912000	-120	1	2.5 ~ 9.0	120	27 ~ 57	66	0 ~ 4	45	26	—	HDP-09				
3090 50913500	-135	1	2.5 ~ 9.0	135	27 ~ 57	81	0 ~ 4	45	26	—	HDP-09				
3090 50916500	-165	1	2.5 ~ 9.0	165	27 ~ 57	111	0 ~ 4	45	26	—	HDP-09	4.1			
3090 50919500	-195	1	2.5 ~ 9.0	195	27 ~ 57	141	0 ~ 4	45	26	—	HDP-09				
3090 50922500	-225	1	2.5 ~ 9.0	225	27 ~ 57	171	0 ~ 4	45	26	—	HDP-09	4.3			
3090 50925500	-255	1	2.5 ~ 9.0	255	27 ~ 57	201	0 ~ 4	45	26	—	HDP-09	4.4			
3090 51209000	BT50 -HDZ12 -90	1	2.5 ~ 12.0	90	33 ~ 69	32	0 ~ 5	56	32	—	HDP-12	4.0			
3090 51210500	-105	1	2.5 ~ 12.0	105	33 ~ 69	47	0 ~ 5	56	32	—	HDP-12				
3090 51212000	-120	1	2.5 ~ 12.0	120	33 ~ 69	62	0 ~ 5	56	32	—	HDP-12	4.1			
3090 51213500	-135	1	2.5 ~ 12.0	135	33 ~ 69	77	0 ~ 5	56	32	—	HDP-12				
3090 51216500	-165	1	2.5 ~ 12.0	165	33 ~ 69	107	0 ~ 5	56	32	—	HDP-12				
3090 51219500	-195	1	2.5 ~ 12.0	195	33 ~ 69	137	0 ~ 5	56	32	—	HDP-12				
3090 51222500	-225	1	2.5 ~ 12.0	225	33 ~ 69	167	0 ~ 5	56	32	—	HDP-12	4.6			
3090 51225500	-255	1	2.5 ~ 12.0	255	33 ~ 69	197	0 ~ 5	56	32	—	HDP-12	4.8			
3090 51609000	BT50 -HDZ16 -90	1	3.5 ~ 16.0	90	38 ~ 82	32	0 ~ 6	62	36	—	HDP-16	4.1	FDC-16	S-4L	L-4T
3090 51610500	-105	1	3.5 ~ 16.0	105	38 ~ 82	47	0 ~ 6	62	36	—	HDP-16	4.2			
3090 51612000	-120	1	3.5 ~ 16.0	120	38 ~ 82	62	0 ~ 6	62	36	—	HDP-16	4.3			
3090 51613500	-135	1	3.5 ~ 16.0	135	38 ~ 82	77	0 ~ 6	62	36	—	HDP-16	4.3			
3090 51616500	-165	1	3.5 ~ 16.0	165	38 ~ 82	107	0 ~ 6	62	36	—	HDP-16	4.5			
3090 51619500	-195	1	3.5 ~ 16.0	195	38 ~ 82	137	0 ~ 6	62	36	—	HDP-16	4.7			
3090 51622500	-225	1	3.5 ~ 16.0	225	38 ~ 82	167	0 ~ 6	62	36	—	HDP-16	4.9			
3090 51625500	-255	1	3.5 ~ 16.0	255	38 ~ 82	197	0 ~ 6	62	36	—	HDP-16	5.1			
3090 52210500	BT50 -HDZ22 -105	1	3.5 ~ 22.0	105	47 ~ 103	43	0 ~ 8	76	46	—	HDP-22	4.5			
3090 52212000	-120	1	3.5 ~ 22.0	120	47 ~ 103	58	0 ~ 8	76	46	—	HDP-22	4.6			
3090 52213500	-135	1	3.5 ~ 22.0	135	47 ~ 103	73	0 ~ 8	76	46	—	HDP-22	4.8			
3090 52215000	-150	1	3.5 ~ 22.0	150	47 ~ 103	88	0 ~ 8	76	46	—	HDP-22	5.0			
3090 52216500	-165	1	3.5 ~ 22.0	165	47 ~ 103	103	0 ~ 8	76	46	—	HDP-22	5.1			
3090 52219500	-195	1	3.5 ~ 22.0	195	47 ~ 103	133	0 ~ 8	76	46	—	HDP-22	5.4			
3090 52222500	-225	1	3.5 ~ 22.0	225	47 ~ 103	163	0 ~ 8	76	46	—	HDP-22	5.7			
3090 52225500	-255	1	3.5 ~ 22.0	255	47 ~ 103	193	0 ~ 8	76	46	—	HDP-22	6.0			

1. Collet, spanner, hexagon head preset screw, preset screw for semi-dry processing, and hex. wrench are sold separately. Standard preset screw is included.

2. Refer to P. 092 for minimum tool insertion length in case of using our coolant collets (OH,C or MS).

3. L1 indicates dimension when using with a preset screw.

4. See P.499 for standard Tightening Torque.

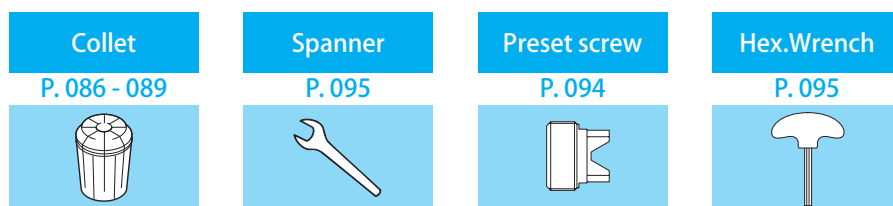

Ordering Example

BT40 - HDZ 12 - 90
 Shank size Max. Projection
 collet I.D. length (L)

HDZ

"R"Zero Holder

- Runout accuracy of the cutting edge can be adjusted as closely as to zero.

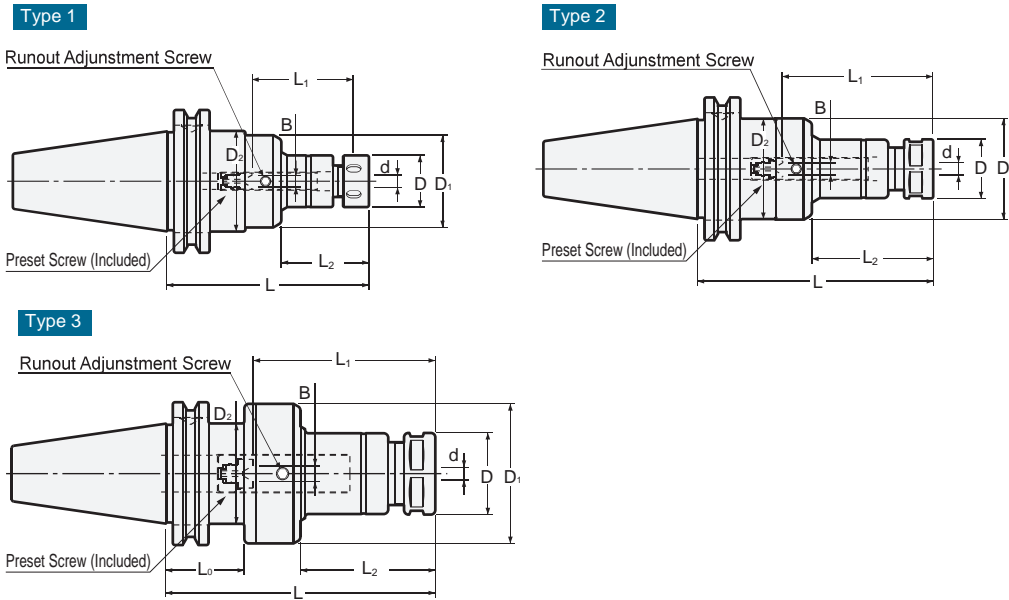





Unit : Inch

Code	Model	Type	d	L	L1	L2	B	D	D1	L0	D2	kg	Preset Screw	Nut	Spanner	Collet	Hex. Wrench (Size)
1960 00407090	CAT40-HDZ07 -90	1	0.020-0.276	3.543	0.866-1.772	1.535	0.0-0.157	0.906	1.614	—	1.750		HDS-07	HDP-07A	S-0	FDC-07	L-3T (3mm)
1960 00407105	-105	1	0.020-0.276	4.134	0.866-1.772	2.126	0.0-0.157	0.906	1.614	—	1.750						
1960 00409090	CAT40-HDZ09 -90	2	0.098-0.354	3.543	1.063-2.244	1.535	0.0-0.157	1.024	1.772	—	1.750		HDS-09	HDP-09	S-1L	FDC-09	
1960 00409105	-105	2	0.098-0.354	4.134	1.063-2.244	2.126	0.0-0.157	1.024	1.772	—	1.750						
1960 00409120	-120	2	0.098-0.354	4.724	1.063-2.244	2.717	0.0-0.157	1.024	1.772	—	1.750						
1960 00409135	-135	2	0.098-0.354	5.315	1.063-2.244	3.307	0.0-0.157	1.024	1.772	—	1.750						
1960 00409165	-165	2	0.098-0.354	6.496	1.063-2.244	4.488	0.0-0.157	1.024	1.772	—	1.750						
1960 00412105	CAT40-HDZ12 -105	3	0.098-0.472	4.134	1.299-2.677	1.772	0.0-0.197	1.260	2.205	1.378	1.750		HDS-12	HDP-12	S-3L	FDC-12	L-4T (4mm)
1960 00412120	-120	3	0.098-0.472	4.724	1.299-2.677	2.362	0.0-0.197	1.260	2.205	1.378	1.750						
1960 00412135	-135	3	0.098-0.472	5.315	1.299-2.677	2.953	0.0-0.197	1.260	2.205	1.378	1.750						
1960 00412165	-165	3	0.098-0.472	6.496	1.299-2.677	4.134	0.0-0.197	1.260	2.205	1.378	1.750						
1960 00412195	-195	3	0.098-0.472	7.677	1.299-2.677	5.315	0.0-0.197	1.260	2.205	1.378	1.750						
1960 00416105	CAT40-HDZ16 -105	3	0.138-0.630	4.134	1.496-3.189	1.772	0.0-0.236	1.417	2.441	1.378	1.750		HDS-16	HDP-16	S-4L	FDC-16	L-5T (5mm)
1960 00416120	-120	3	0.138-0.630	4.724	1.496-3.189	2.362	0.0-0.236	1.417	2.441	1.378	1.750						
1960 00416135	-135	3	0.138-0.630	5.315	1.496-3.189	2.953	0.0-0.236	1.417	2.441	1.378	1.750						
1960 00416165	-165	3	0.138-0.630	6.496	1.496-3.189	4.134	0.0-0.236	1.417	2.441	1.378	1.750						
1960 00416195	-195	3	0.138-0.630	7.677	1.496-3.189	5.315	0.0-0.236	1.417	2.441	1.378	1.750						
1960 00422105	CAT40-HDZ22 -105	3	0.138-0.866	4.134	1.850-4.055	1.220	0.0-0.315	1.811	2.717	1.378	1.750		HDS-22	HDP-22	S-5L	FDC-22	L-5T (5mm)
1960 00422120	-120	3	0.138-0.866	4.724	1.850-4.055	1.811	0.0-0.315	1.811	2.717	1.378	1.750						
1960 00422135	-135	3	0.138-0.866	5.315	1.850-4.055	2.402	0.0-0.315	1.811	2.717	1.378	1.750						
1960 00422165	-165	3	0.138-0.866	6.496	1.850-4.055	3.583	0.0-0.315	1.811	2.717	1.378	1.750						
1960 00422195	-195	3	0.138-0.866	7.677	1.850-4.055	4.764	0.0-0.315	1.811	2.717	1.378	1.750						
1960 00507090	CAT50-HDZ07 -90	1	0.020-0.276	3.543	0.866-1.772	1.535	0.0-0.157	0.906	1.614	—	2.750		HDS-07	HDP-07A	S-0	FDC-07	L-3T (3mm)
1960 00507105	-105	1	0.020-0.276	4.134	0.866-1.772	2.126	0.0-0.157	0.906	1.614	—	2.750						
1960 00507120	-120	1	0.020-0.276	4.724	0.866-1.772	2.717	0.0-0.157	0.906	1.614	—	2.750	3.3					
1960 00507135	-135	1	0.020-0.276	5.315	0.866-1.772	3.307	0.0-0.157	0.906	1.614	—	2.750						
1960 00507165	-165	1	0.020-0.276	6.496	0.866-1.772	4.291	0.0-0.157	0.906	1.614	—	2.750						
1960 00507195	-195	1	0.020-0.276	7.677	0.866-1.772	5.669	0.0-0.157	0.906	1.614	—	2.750						
1960 00509090	CAT50-HDZ09 -90	1	0.098-0.354	3.543	1.063-2.244	1.378	0.0-0.157	1.024	1.772	—	2.750		HDS-09	HDP-09	S-1L	FDC-09	L-3T (3mm)
1960 00509105	-105	1	0.098-0.354	4.134	1.063-2.244	1.969	0.0-0.157	1.024	1.772	—	2.750	3.3					
1960 00509120	-120	1	0.098-0.354	4.724	1.063-2.244	2.559	0.0-0.157	1.024	1.772	—	2.750						
1960 00509135	-135	1	0.098-0.354	5.315	1.063-2.244	3.150	0.0-0.157	1.024	1.772	—	2.750	3.4					
1960 00509165	-165	1	0.098-0.354	6.496	1.063-2.244	4.331	0.0-0.157	1.024	1.772	—	2.750						
1960 00509195	-195	1	0.098-0.354	7.677	1.063-2.244	5.512	0.0-0.157	1.024	1.772	—	2.750						
1960 00509225	-225	1	0.098-0.354	8.858	1.063-2.244	6.693	0.0-0.157	1.024	1.772	—	2.750						
1960 00509255	-255	1	0.098-0.354	10.039	1.063-2.244	7.874	0.0-0.157	1.024	1.772	—	2.750						

Code	Model	Type	d	L	L1	L2	B	D	D1	L0	D2	kg	Preset Screw	Nut	Spanner	Collet	Hex. Wrench (Size)					
1960 00512090	CAT50-HDZ12 - 90	1	0.098-0.472	3.543	1.299-2.677	1.378	0.0-0.197	1.260	2.205	—	2.750	3.5	HDS-12	HDP-12	S-3L	FDC-12	L-4T (4mm)					
1960 00512105	-105	1	0.098-0.472	4.134	1.299-2.677	1.969	0.0-0.197	1.260	2.205	—	2.750											
1960 00512120	-120	1	0.098-0.472	4.724	1.299-2.677	2.559	0.0-0.197	1.260	2.205	—	2.750											
1960 00512135	-135	1	0.098-0.472	5.315	1.299-2.677	3.150	0.0-0.197	1.260	2.205	—	2.750											
1960 00512165	-165	1	0.098-0.472	6.496	1.299-2.677	4.331	0.0-0.197	1.260	2.205	—	2.750											
1960 00512195	-195	1	0.098-0.472	7.677	1.299-2.677	5.512	0.0-0.197	1.260	2.205	—	2.750											
1960 00512225	-225	1	0.098-0.472	8.858	1.299-2.677	6.693	0.0-0.197	1.260	2.205	—	2.750											
1960 00512255	-255	1	0.098-0.472	10.039	1.299-2.677	7.874	0.0-0.197	1.260	2.205	—	2.750											
1960 00516090	CAT50-HDZ16 - 90	1	0.138-0.630	3.543	1.496-3.189	1.378	0.0-0.236	1.417	2.441	—	2.750							3.6	HDS-16	HDP-16	S-4L	FDC-16
1960 00516105	-105	1	0.138-0.630	4.134	1.496-3.189	1.969	0.0-0.236	1.417	2.441	—	2.750											
1960 00516120	-120	1	0.138-0.630	4.724	1.496-3.189	2.559	0.0-0.236	1.417	2.441	—	2.750											
1960 00516135	-135	1	0.138-0.630	5.315	1.496-3.189	3.150	0.0-0.236	1.417	2.441	—	2.750											
1960 00516165	-165	1	0.138-0.630	6.496	1.496-3.189	4.331	0.0-0.236	1.417	2.441	—	2.750											
1960 00516195	-195	1	0.138-0.630	7.677	1.496-3.189	5.512	0.0-0.236	1.417	2.441	—	2.750											
1960 00516225	-225	1	0.138-0.630	8.858	1.496-3.189	6.693	0.0-0.236	1.417	2.441	—	2.750											
1960 00516255	-255	1	0.138-0.630	10.039	1.496-3.189	7.874	0.0-0.236	1.417	2.441	—	2.750											
1960 00522105	CAT50-HDZ22 -105	3	0.138-0.866	4.134	1.850-4.055	2.205	0.0-0.315	1.811	2.992	1.378	2.750	4.1	HDS-22	HDP-22	S-5L	FDC-22	L-5T (5mm)					
1960 00522120	-120	3	0.138-0.866	4.724	1.850-4.055	2.795	0.0-0.315	1.811	2.992	1.378	2.750											
1960 00522135	-135	3	0.138-0.866	5.315	1.850-4.055	3.386	0.0-0.315	1.811	2.992	1.378	2.750											
1960 00522165	-165	3	0.138-0.866	6.496	1.850-4.055	3.976	0.0-0.315	1.811	2.992	1.378	2.750											
1960 00522195	-195	3	0.138-0.866	7.677	1.850-4.055	5.157	0.0-0.315	1.811	2.992	1.378	2.750											
1960 00522225	-225	3	0.138-0.866	8.858	1.850-4.055	6.339	0.0-0.315	1.811	2.992	1.378	2.750											
1960 00522255	-255	3	0.138-0.866	10.039	1.850-4.055	7.520	0.0-0.315	1.811	2.992	1.378	2.750											

- 1.Collet, spanner, hexagon head preset screw, preset screw for semi-dry processing, and hex. wrench are sold separately. Standard preset screw is included.
- 2.Refer to P.092 for minimum tool insertion length in case of using our coolant collets (OH,C or MS).
- 3.L1 indicates dimension when using with a preset screw.
- 4.See P.499 for standard Tightening Torque.
- 5.Standard preset screw is included.

<p>Collet</p> <p>P. 086 - 089</p> 	<p>Spanner</p> <p>P. 095</p> 	<p>Preset screw</p> <p>P. 094</p> 	<p>Hex. wrench</p> <p>P. 095</p> 
--	---	--	---

Ordering Example

CAT40 - HDZ 12 - 150
 Shank size Max. collet I.D. Projection length (L)

- BT
- CAT
- AHO
- HSK-A/E/F/C
- HSK-T
- UTS
- Specialized Machine
- Related Equipment
- Bush & Chamfering Drill
- Milling Chuck
- Collet Holder
- R- Zero Holder
- Hydraulic Chuck
- Shrink fit
- Tapping Chuck
- Arbors
- Function Holder
- Retention Stud
- Tool Shank Dimensions

HDZ

"R"Zero Holder

- Runout accuracy of the cutting edge can be adjusted as closely as to zero.

Type1

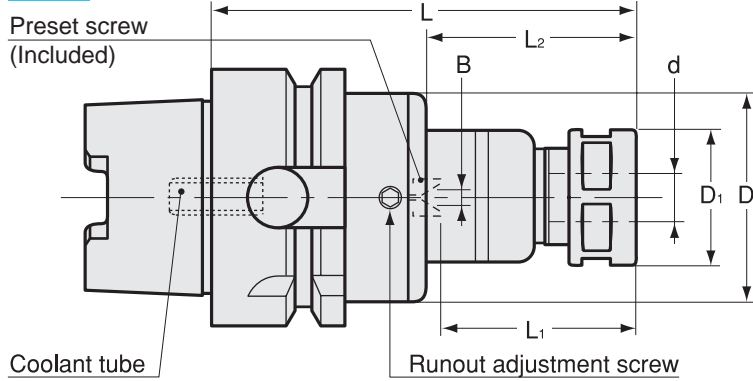

Type2

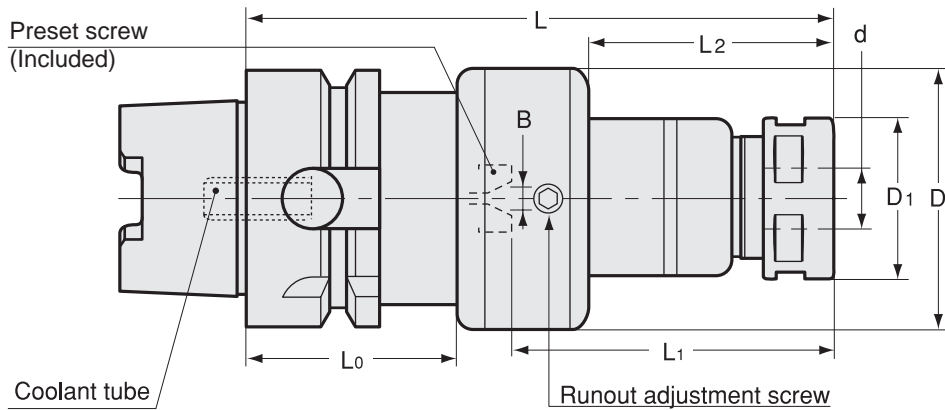

- Coolant tube is included.

Unit : Metric

Code	Model	Type	d	L	L1	L2	B	D	D1	L0	Nut	kg	Collet	Spanner	Wrench
5650 13007075	HSK40A -HDZ07 -75	1	0.5 ~ 7.0	75	22 ~ 38	39	0 ~ 4	34	23	—	HDP-07A		FDC-07	S-0	L-3T
5650 13007090	-90	1	0.5 ~ 7.0	90	22 ~ 49	54	0 ~ 4	34	23	—	HDP-07A		FDC-07	S-0	L-3T
5650 13007120	-120	1	0.5 ~ 7.0	120	22 ~ 49	84	0 ~ 4	34	23	—	HDP-07A	0.5	FDC-07	S-0	L-3T
5650 13009090	HSK40A -HDZ09 -90	2	2.5 ~ 9.0	90	27 ~ 46	34	0 ~ 4	41	26	35	HDP-09	0.6	FDC-09	S-1L	L-3T
5650 13009120	-120	2	2.5 ~ 9.0	120	27 ~ 61	64	0 ~ 4	41	26	35	HDP-09		FDC-09	S-1L	L-3T
5650 13012090	HSK40A -HDZ12 -90	2	2.5 ~ 12.0	90	33 ~ 51	30	0 ~ 5	52	32	35	HDP-12	0.8	FDC-12	S-3L	L-4T
5650 13012120	-120	2	2.5 ~ 12.0	120	33 ~ 74	60	0 ~ 5	52	32	35	HDP-12	1.0	FDC-12	S-3L	L-4T
5650 13012150	-150	2	2.5 ~ 12.0	150	33 ~ 74	90	0 ~ 5	52	32	35	HDP-12		FDC-12	S-3L	L-4T
5650 13016090	HSK40A -HDZ16 -90	2	3.5 ~ 16.0	90	38 ~ 54	30	0 ~ 6	56	36	35	HDP-16	0.9	FDC-16	S-4L	L-4T
5650 13016120	-120	2	3.5 ~ 16.0	120	38 ~ 72	60	0 ~ 6	56	36	35	HDP-16	1.1	FDC-16	S-4L	L-4T
5650 13016150	-150	2	3.5 ~ 16.0	150	38 ~ 86	90	0 ~ 6	56	36	35	HDP-16		FDC-16	S-4L	L-4T
5650 14007075	HSK50A -HDZ07 -75	1	0.5 ~ 7.0	75	22 ~ 32	33	0 ~ 4	41	23	—	HDP-07A		FDC-07	S-0	L-3T
5650 14007090	-90	1	0.5 ~ 7.0	90	22 ~ 45	48	0 ~ 4	41	23	—	HDP-07A	0.7	FDC-07	S-0	L-3T
5650 14007120	-120	1	0.5 ~ 7.0	120	22 ~ 45	78	0 ~ 4	41	23	—	HDP-07A	0.8	FDC-07	S-0	L-3T
5650 14009075	HSK50A -HDZ09 -75	1	2.5 ~ 9.0	75	27 ~ 31	33	0 ~ 4	41	26	—	HDP-09		FDC-09	S-1L	L-3T
5650 14009090	-90	1	2.5 ~ 9.0	90	27 ~ 47	48	0 ~ 4	41	26	—	HDP-09	0.7	FDC-09	S-1L	L-3T
5650 14009120	-120	1	2.5 ~ 9.0	120	27 ~ 61	78	0 ~ 4	41	26	—	HDP-09	0.8	FDC-09	S-1L	L-3T
5650 14012090	HSK50A -HDZ12 -90	2	2.5 ~ 12.0	90	33 ~ 42	23	0 ~ 5	52	32	42	HDP-12	1.0	FDC-12	S-3L	L-4T
5650 14012120	-120	2	2.5 ~ 12.0	120	33 ~ 71	53	0 ~ 5	52	32	42	HDP-12	1.2	FDC-12	S-3L	L-4T
5650 14012150	-150	2	2.5 ~ 12.0	150	33 ~ 74	83	0 ~ 5	52	32	42	HDP-12	1.4	FDC-12	S-3L	L-4T
5650 14016090	HSK50A -HDZ16 -90	2	3.5 ~ 16.0	90	38 ~ 50	23	0 ~ 6	56	36	42	HDP-16	1.1	FDC-16	S-4L	L-4T
5650 14016120	-120	2	3.5 ~ 16.0	120	38 ~ 65	53	0 ~ 6	56	36	42	HDP-16	1.3	FDC-16	S-4L	L-4T
5650 14016150	-150	2	3.5 ~ 16.0	150	38 ~ 86	83	0 ~ 6	56	36	42	HDP-16	1.5	FDC-16	S-4L	L-4T

Code	Model	Type	d	L	L1	L2	B	D	D1	L0	Nut	kg	Collet	Spanner	Wrench
5650 15007075	HSK63A -HDZ07 -75	1	0.5 ~ 7.0	75	22 ~ 35	33	0 ~ 4	41	23	—	HDP-07A	0.9	FDC-07	S-0	L-3T
5650 15007090	-90	1	0.5 ~ 7.0	90	22 ~ 45	48	0 ~ 4	41	23	—	HDP-07A				
5650 15007120	-120	1	0.5 ~ 7.0	120	22 ~ 45	78	0 ~ 4	41	23	—	HDP-07A				
5650 15009075	HSK63A -HDZ09 -75	1	2.5 ~ 9.0	75	27 ~ 34	33	0 ~ 4	45	26	—	HDP-09	1.0	FDC-09	S-1L	L-3T
5650 15009090	-90	1	2.5 ~ 9.0	90	27 ~ 42	48	0 ~ 4	45	26	—	HDP-09	1.0			
5650 15009120	-120	1	2.5 ~ 9.0	120	27 ~ 57	78	0 ~ 4	45	26	—	HDP-09				
5650 15012090	HSK63A -HDZ12 -90	1	2.5 ~ 12.0	90	33 ~ 48	44	0 ~ 5	52	32	—	HDP-12	1.2	FDC-12	S-3L	L-4T
5650 15012120	-120	1	2.5 ~ 12.0	120	33 ~ 69	74	0 ~ 5	52	32	—	HDP-12	1.3			
5650 15012150	-150	1	2.5 ~ 12.0	150	33 ~ 69	104	0 ~ 5	52	32	—	HDP-12	1.5			
5650 15016090	HSK63A -HDZ16 -90	2	3.5 ~ 16.0	90	38 ~ 48	28	0 ~ 6	56	36	42	HDP-16	1.4	FDC-16	S-4L	L-4T
5650 15016120	-120	2	3.5 ~ 16.0	120	38 ~ 62	58	0 ~ 6	56	36	42	HDP-16	1.6			
5650 15016150	-150	2	3.5 ~ 16.0	150	38 ~ 82	88	0 ~ 6	56	36	42	HDP-16	1.8			
5650 15022120	HSK63A -HDZ22 -120	2	3.5 ~ 22.0	120	47 ~ 63	49	0 ~ 8	69	46	42	HDP-22	2.0	FDC-22	S-5L	L-5T
5650 15022150	-150	2	3.5 ~ 22.0	150	47 ~ 93	79	0 ~ 8	69	46	42	HDP-22	2.3			
5650 17007075	HSK100A -HDZ07 -75	1	0.5 ~ 7.0	75	22 ~ 27	26	0 ~ 4	41	23	—	HDP-07A		FDC-07	S-0	L-3T
5650 17007090	-90	1	0.5 ~ 7.0	90	22 ~ 45	41	0 ~ 4	41	23	—	HDP-07A				
5650 17007120	-120	1	0.5 ~ 7.0	120	22 ~ 45	71	0 ~ 4	41	23	—	HDP-07A				
5650 17009075	HSK100A -HDZ09 -75	1	2.5 ~ 9.0	75	27 ~ 28	26	0 ~ 4	45	26	—	HDP-09		FDC-09	S-1L	L-3T
5650 17009090	-90	1	2.5 ~ 9.0	90	27 ~ 47	41	0 ~ 4	45	26	—	HDP-09	2.4			
5650 17009120	-120	1	2.5 ~ 9.0	120	27 ~ 57	71	0 ~ 4	45	26	—	HDP-09				
5650 17012090	HSK100A -HDZ12 -90	1	2.5 ~ 12.0	90	33 ~ 41	41	0 ~ 5	56	32	—	HDP-12	2.6	FDC-12	S-3L	L-4T
5650 17012120	-120	1	2.5 ~ 12.0	120	33 ~ 59	71	0 ~ 5	56	32	—	HDP-12				
5650 17012150	-150	1	2.5 ~ 12.0	150	33 ~ 69	101	0 ~ 5	56	32	—	HDP-12	2.9			
5650 17016090	HSK100A -HDZ16 -90	1	3.5 ~ 16.0	90	38 ~ 41	41	0 ~ 6	62	36	—	HDP-16	2.7	FDC-16	S-4L	L-4T
5650 17016120	-120	1	3.5 ~ 16.0	120	38 ~ 62	71	0 ~ 6	62	36	—	HDP-16				
5650 17016150	-150	1	3.5 ~ 16.0	150	38 ~ 82	101	0 ~ 6	62	36	—	HDP-16				
5650 17022090	HSK100A -HDZ22 -90	1	3.5 ~ 22.0	90	56	37	—	76	46	—	HDP-22	3.0	FDC-22	S-5L	L-5T
5650 17022120	-120	1	3.5 ~ 22.0	120	47 ~ 59	67	0 ~ 8	76	46	—	HDP-22	3.4			
5650 17022150	-150	1	3.5 ~ 22.0	150	47 ~ 83	97	0 ~ 8	76	46	—	HDP-22				

1. Collet, spanner, hexagon head preset screw, preset screw for semi-dry processing, and adjustment wrench are sold separately. Standard preset screw is included.

2. Refer to P.092 for minimum tool insertion length in case of using our coolant collets (OH,C or MS).

3. L1 indicates dimension when using with a preset screw.

4. See P.499 for standard Tightening Torque.

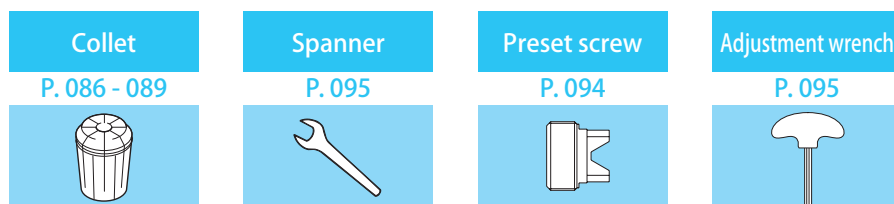

Ordering Example

HSK40A - HDZ 12 - 90

Shank size

Max.
collet I.D.

Projection
length (L)

HDZ

"R"Zero Holder

● Runout accuracy of the cutting edge can be adjusted as closely as to zero.

Type1

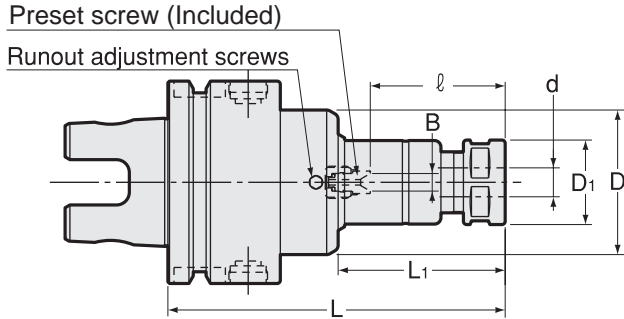

Type2

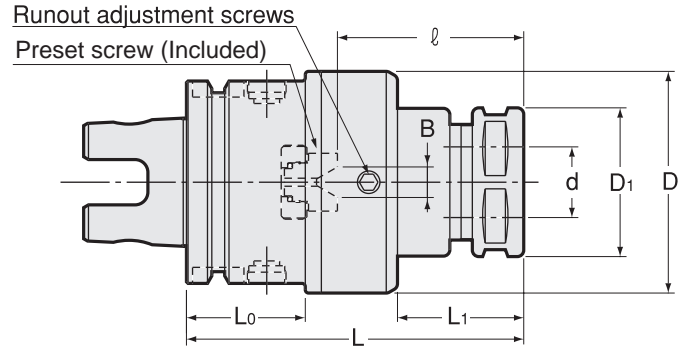

Unit : Metric





Code	Model	Type	d	L	ℓ	B	D	L1	L0	D1	Nut	kg	Collet	Spanner	Wrench
1250 01107075	UTS5040 -HDZ07 -75-H	1	0.5 ~ 7.0	75	22 ~ 32	0 ~ 4	41	29	—	23	HDP-07A				
1250 01107090	-90-H	1	0.5 ~ 7.0	90	22 ~ 45	0 ~ 4	41	44	—	23	HDP-07A		FDC-07	S-0	L-3T
1250 01107120	-120-H	1	0.5 ~ 7.0	120	22 ~ 45	0 ~ 4	41	74	—	23	HDP-07A				
1250 01109075	UTS5040 -HDZ09 -75-H	1	2.5 ~ 9.0	75	27 ~ 31	0 ~ 4	41	29	—	26	HDP-09				
1250 01109090	-90-H	1	2.5 ~ 9.0	90	27 ~ 47	0 ~ 4	41	44	—	26	HDP-09		FDC-09	S-1L	L-3T
1250 01109120	-120-H	1	2.5 ~ 9.0	120	27 ~ 61	0 ~ 4	41	74	—	26	HDP-09				
1250 01112090	UTS5040 -HDZ12 -90-H	2	2.5 ~ 12.0	90	33 ~ 41	0 ~ 5	52	35	30	32	HDP-12				
1250 01112120	-120-H	2	2.5 ~ 12.0	120	33 ~ 70	0 ~ 5	52	65	30	32	HDP-12		FDC-12	S-3L	L-4T
1250 01112150	-150-H	2	2.5 ~ 12.0	150	33 ~ 73	0 ~ 5	52	95	30	32	HDP-12				
1250 01116090	UTS5040 -HDZ16 -90-H	2	3.5 ~ 16.0	90	38 ~ 49	0 ~ 6	56	35	30	36	HDP-16				
1250 01116120	-120-H	2	3.5 ~ 16.0	120	38 ~ 64	0 ~ 6	56	65	30	36	HDP-16		FDC-16	S-4L	L-4T
1250 01116150	-150-H	2	3.5 ~ 16.0	150	38 ~ 85	0 ~ 6	56	95	30	36	HDP-16				
1250 0 ※ 207075	UTS6350 -HDZ07 -75	1	0.5 ~ 7.0	75	22 ~ 34	0 ~ 4	41	26	—	23	HDP-07A				
1250 0 ※ 207090	-90	1	0.5 ~ 7.0	90	22 ~ 45	0 ~ 4	41	41	—	23	HDP-07A	1.1	FDC-07	S-0	L-3T
1250 0 ※ 207120	-120	1	0.5 ~ 7.0	120	22 ~ 45	0 ~ 4	41	71	—	23	HDP-07A	1.2			
1250 0 ※ 209075	UTS6350 -HDZ09 -75	1	2.5 ~ 9.0	75	27 ~ 34	0 ~ 4	45	26	—	26	HDP-09				
1250 0 ※ 209090	-90	1	2.5 ~ 9.0	90	27 ~ 42	0 ~ 4	45	41	—	26	HDP-09	1.1	FDC-09	S-1L	L-3T
1250 0 ※ 209120	-120	1	2.5 ~ 9.0	120	27 ~ 57	0 ~ 4	45	71	—	26	HDP-09	1.3			
1250 0 ※ 212090	UTS6350 -HDZ12 -90	1	2.5 ~ 12.0	90	33 ~ 47	0 ~ 5	52	37	—	32	HDP-12	1.3			
1250 0 ※ 212120	-120	1	2.5 ~ 12.0	120	33 ~ 69	0 ~ 5	52	67	—	32	HDP-12		FDC-12	S-3L	L-4T
1250 0 ※ 212150	-150	1	2.5 ~ 12.0	150	33 ~ 69	0 ~ 5	52	97	—	32	HDP-12	1.6			
1250 0 ※ 216090	UTS6350 -HDZ16 -90	1	3.5 ~ 16.0	90	38 ~ 47	0 ~ 6	56	37	33	36	HDP-16	1.3			
1250 0 ※ 216120	-120	1	3.5 ~ 16.0	120	38 ~ 61	0 ~ 6	56	67	33	36	HDP-16	1.5	FDC-16	S-4L	L-4T
1250 0 ※ 216150	-150	1	3.5 ~ 16.0	150	38 ~ 61	0 ~ 6	56	97	33	36	HDP-16				
1250 0 ※ 222120	UTS6350 -HDZ22 -120	2	3.5 ~ 22.0	120	47 ~ 62	0 ~ 8	69	58	33	46	HDP-22	2.0	FDC-22	S-5L	L-5T
1250 0 ※ 222150	-150	2	3.5 ~ 22.0	150	47 ~ 92	0 ~ 8	69	88	33	46	HDP-22				

Unit : Metric

Code	Model	Type	d	L	ℓ	B	D	L1	L0	D1	Nut	kg	Collet	Spanner	Wrench
1250 0 ※ 307075	UTS10080 -HDZ07 -75	1	0.5 ~ 7.0	75	22 ~ 26	0 ~ 4	41	25	—	23	HDP-07A				
1250 0 ※ 307090	-90	1	0.5 ~ 7.0	90	22 ~ 45	0 ~ 4	41	40	—	23	HDP-07A		FDC-07	S-0	L-3T
1250 0 ※ 307120	-120	1	0.5 ~ 7.0	120	22 ~ 45	0 ~ 4	41	70	—	23	HDP-07A				
1250 0 ※ 309075	UTS10080 -HDZ09 -75	1	2.5 ~ 9.0	75	27	0 ~ 4	45	25	—	26	HDP-09				
1250 0 ※ 309090	-90	1	2.5 ~ 9.0	90	27 ~ 47	0 ~ 4	45	40	—	26	HDP-09		FDC-09	S-1L	L-3T
1250 0 ※ 309120	-120	1	2.5 ~ 9.0	120	27 ~ 57	0 ~ 4	45	70	—	26	HDP-09				
1250 0 ※ 312090	UTS10080 -HDZ12 -90	1	2.5 ~ 12.0	90	33 ~ 41	0 ~ 5	56	36	—	32	HDP-12				
1250 0 ※ 312120	-120	1	2.5 ~ 12.0	120	33 ~ 59	0 ~ 5	56	66	—	32	HDP-12		FDC-12	S-3L	L-4T
1250 0 ※ 312150	-150	1	2.5 ~ 12.0	150	33 ~ 69	0 ~ 5	56	96	—	32	HDP-12				
1250 0 ※ 316090	UTS10080 -HDZ16 -90	1	3.5 ~ 16.0	90	38 ~ 41	0 ~ 6	62	36	—	36	HDP-16				
1250 0 ※ 316120	-120	1	3.5 ~ 16.0	120	38 ~ 59	0 ~ 6	62	66	—	36	HDP-16		FDC-16	S-4L	L-4T
1250 0 ※ 316150	-150	1	3.5 ~ 16.0	150	38 ~ 69	0 ~ 6	62	96	—	36	HDP-16				
1250 0 ※ 322090	UTS10080 -HDZ22 -90	1	3.5 ~ 22.0	90	56	0 ~ 8	76	32	—	46	HDP-22				
1250 0 ※ 322120	-120	1	3.5 ~ 22.0	120	47 ~ 58	0 ~ 8	76	62	—	46	HDP-22		FDC-22	S-5L	L-5T
1250 0 ※ 322150	-150	1	3.5 ~ 22.0	150	47 ~ 82	0 ~ 8	76	92	—	46	HDP-22				

When placing an order, please specify high or low pressure. For high pressure type, please add (-H) on end of the description.

- 1.Collet, spanner, hexagon head preset screw, preset screw for semi-dry processing are sold separately. Standard preset screw is included.
- 2.Refer to P.092 for minimum tool insertion length in case of using our coolant collets (OH,C or MS).
- 3.ℓ indicates dimension when using with a preset screw.
- 4.UTS5040 is available in high pressure only.
- 5.See P.499 for standard Tightening Torque.

<p>Collet P. 086 - 089</p> 	<p>Spanner P. 095</p> 	<p>Preset screw P. 094</p> 	<p>Adjustment wrench P. 095</p> 
---	--	---	--

Ordering Example

Low pressure type
0 ~ 1.0MPa (UTS10080 : 0 ~ 2.0MPa)
UTS6350 - HDZ 12 - 90
Shank size Max. collet I.D. Projection length (L)

Ordering Example

High pressure type
1.1 ~ 7.0MPa (UTS10080 : 2.1 ~ 7.0MPa)
UTS6350 - HDZ 12 - 90 - H
Shank size Max. collet I.D. Projection length (L) High pressure type