

Chamfering Cutter Series

FM Chamfering cutter

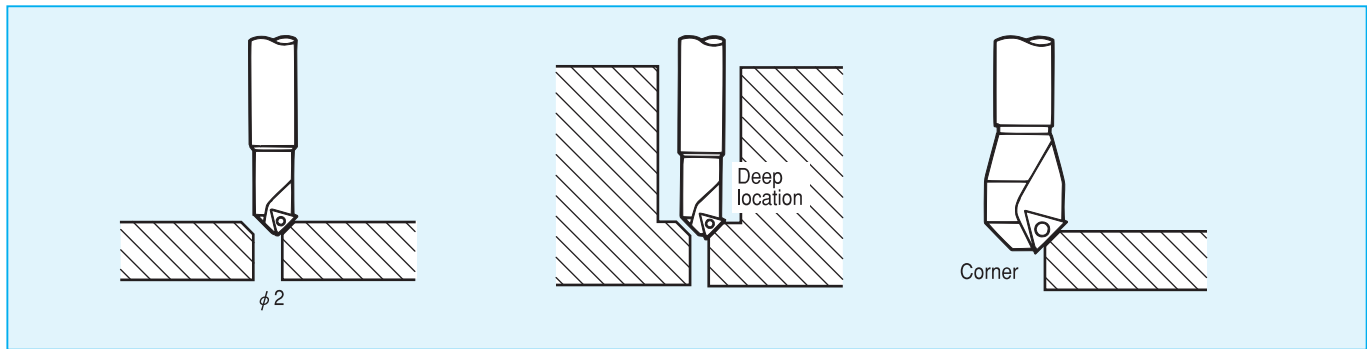

Chamfering, countersinking and corner rounding with machining center and milling machine.

BM Back chamfering cutter

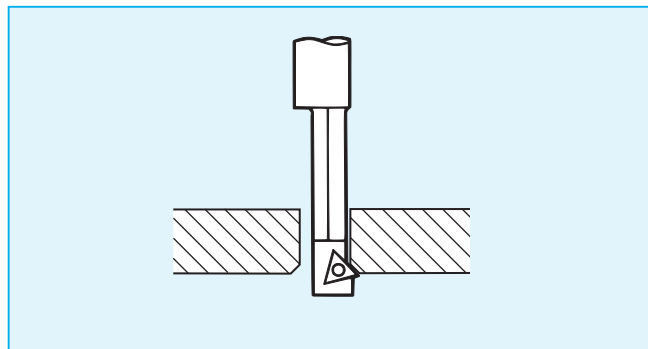

Back spot-facing with axially adjustable machines such as machining center and milling machine.

BZ Back spot-facing cutter

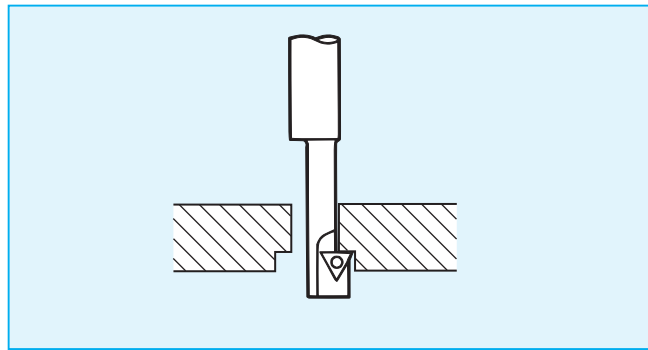

Back chamfering with axially adjustable machines such as machining center and milling machine.

BM

Back Chamfering Cutter

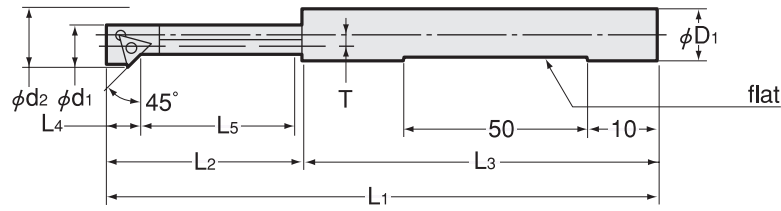

Code	Model	ϕ d1	ϕ d2	T	ϕ D1	L1	L2	L3	L4	L5	kg	Insert No.
2840 01068095	BM068095	6.8	9.5	1.8	12.0	109	39	70	5	32	0.07	TBGT060102R
2840 01085115	BM085115	8.5	11.5	2.1	12.0	119	49	70	5	42	0.07	TBGT060102R
2840 01100140	BM100140	10.0	14.0	2.8	16.0	131	61	70	7	52	0.13	TPMT090202
2840 01120160	BM120160	12.0	16.0	2.8	16.0	136	66	70	7	57	0.14	TPMT090202
2840 01140185	BM140185	14.0	18.5	3.2	20.0	142	72	70	8	62	0.21	TPGT110202R
2840 01160205	BM160205	16.0	20.5	3.2	20.0	152	82	70	8	72	0.24	TPGT110202R

Indexable inserts are not included and not available from us. Wrench and clamp screw are included.

Accessories

Wrench	Code	Model	Insert No.	Clamp screw	Code	Model	Insert No.
	2825 00000006	LT-6	TBGT060102R		2825 12004306	CB1-20043-T6	TBGT060102R
	2825 00000007	LT-7	TPMT090202		2625 12204607	CB1-22046-T7	TPMT090202
	2625 00000008	LT-8	TPGT110202R		2625 12504808	CB1-25048-T8	TPGT110202R

Recommended cutting conditions

Cutter	Workpiece					
	S45C		FC250		A2017 (Aluminum)	
	Revolution (min-1)	Feed/rev. (mm/rev)	Revolution (min-1)	Feed/rev. (mm/rev)	Revolution (min-1)	Feed/rev. (mm/rev)
BM068095	1450	0.05	1450	0.05	1450	0.10
BM085115	1250	0.05	1250	0.07	1250	0.10
BM100140	1250	0.07	1250	0.07	1500	0.10
BM120160	1000	0.07	1000	0.10	1300	0.10
BM140185	750	0.07	750	0.10	1100	0.10
BM160205	670	0.15	670	0.15	1000	0.15

ご注文例 Ordering Example

BM 068 095
 最小加工径 最大加工径
 Min. hole dia Max. hole dia