

Chamfering Cutter Series

FM Chamfering cutter

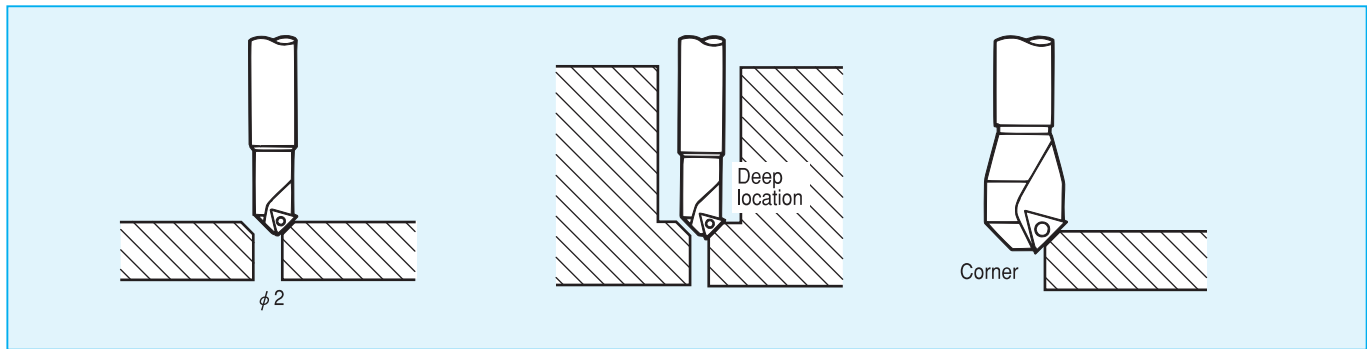

Chamfering, countersinking and corner rounding with machining center and milling machine.

BM Back chamfering cutter

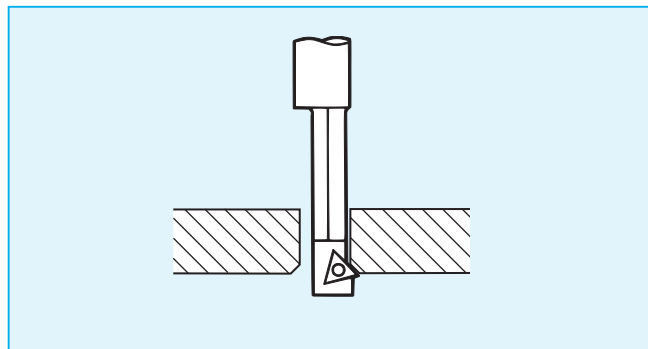

Back spot-facing with axially adjustable machines such as machining center and milling machine.

BZ Back spot-facing cutter

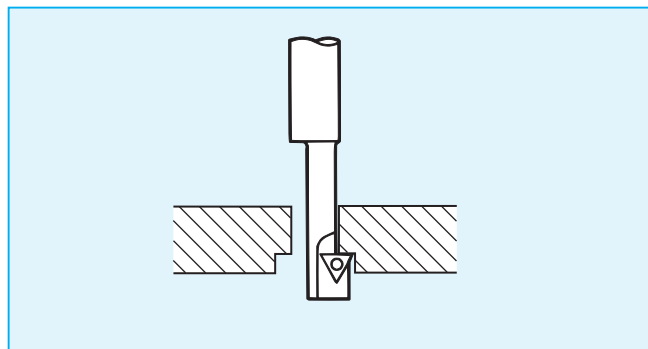

Back chamfering with axially adjustable machines such as machining center and milling machine.

FM

Chamfering Cutter

Type1

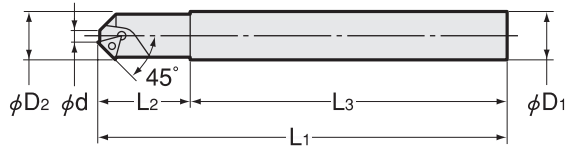

Type2

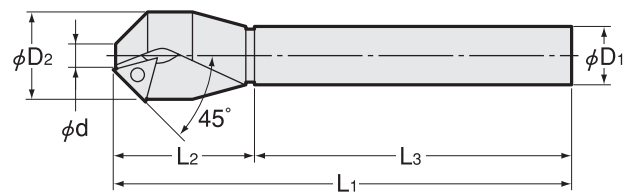

Code	Model	Type	Chamfering dia	φ D1	φ D2	L1	L2	L3	kg	Insert No.
2820 0000209	FM0209	1	2 ~ 9	12	12	140	40	100	0.12	No.520
2820 0000514	FM0514	1	5 ~ 14	16	16	160	60	100	0.23	No.520
2820 00001030	FM1030	2	10 ~ 30	20	32	167	47	120	0.41	No.504

Insert for chamfering cutter is specially designed and available only from NT. (1set=10pcs.)
Other commercialized products cannot be used.
Wrench and screw are included.

Accessories

Insert		Wrench		Clamp screw	
Code	Model	Code	Model	Code	Model
2824 00052010	No.520	2825 00000006	LT-6	2825 12004306	CB1-20043-T6

Insert		Wrench		Clamp screw	
Code	Model	Code	Model	Code	Model
2624 00050410	No.504	2625 00000015	LT-15	6041 00115672	CB1-3507

Recommended cutting conditions

Cutter	Workpiece					
	S45C		FC250		A2017 (Aluminum)	
	Revolution (min ⁻¹)	Feed/rev. (mm/rev)	Revolution (min ⁻¹)	Feed/rev. (mm/rev)	Revolution (min ⁻¹)	Feed/rev. (mm/rev)
FM0209	2100	0.1	2100	0.1	3000	0.1
FM0514	1300	0.1	1300	0.1	1800	0.1
FM1030	1000	0.15	1000	0.15	1300	0.15

Ordering Example

FM 02 09
Min. hole dia Max. hole dia