

PHZ・S New

スリムハイドロ "R" ゼロホルダ

Slim Hydro "R" Zero Holder

- スリムハイドロチャックに "R" ゼロ刃先振れ調整機能を追加。細穴奥の高精度加工などに最適。
Slim Hydro Chuck with "R" zero runout adjustment function. Suitable for high precision cutting in a deep/narrow hole.

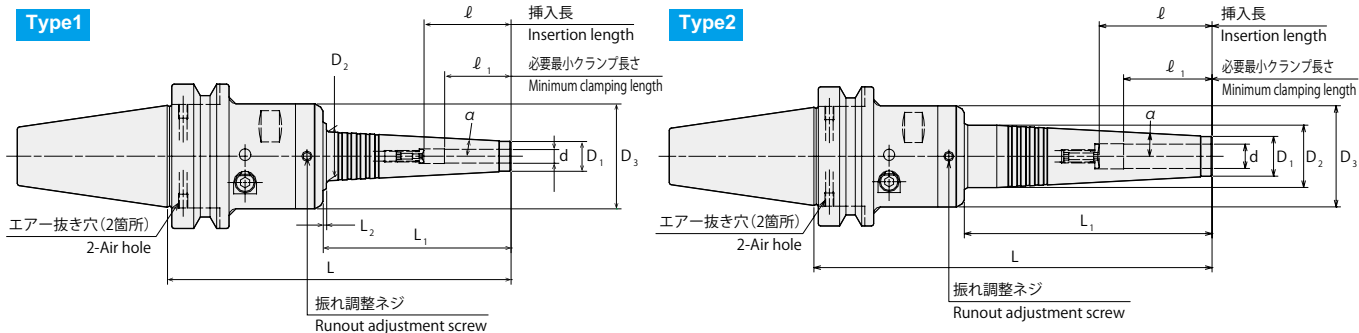

商品コード Code	型式 Model	Type	d	L	L ₁	L ₂	D ₁	D ₂	D ₃	ℓ	ℓ ₁	α	Kg	—	締付レンチ (別売) Hex. wrench for the actuating screw (Option)	調整レンチ (付属) Hex. wrench for runout adjustment screw (Included)
3600 00106150	BT30 -PHZ06S -150	1	6	150	82	1.5	13	21.5	46	37	29	3°	54,000		L-4T	L-3T-S
3600 00106180	-180	1	6	180	112	1.5	13	24.6	46	37	29	3°	55,000			
3600 00107150	-PHZ07S -150	1	7	150	82	1.5	14	22.5	46	37	29	3°	54,000			
3600 00107180	-180	1	7	180	112	1.5	14	25.6	46	37	29	3°	55,000			
3600 00108150	-PHZ08S -150	1	8	150	82	1.5	15	23.5	46	50	29	3°	55,000			
3600 00108180	-180	1	8	180	112	1.5	15	26.6	46	50	29	3°	56,000			
3600 00109150	-PHZ09S -150	1	9	150	82	1.5	16	24.5	46	50	40	3°	55,000			
3600 00109180	-180	1	9	180	112	—	16	27.6	46	50	40	3°	56,000			
3600 00110150	-PHZ10S -150	1	10	150	82	1.5	17	25.5	46	50	40	3°	56,000			
3600 00110180	-180	2	10	180	112	—	17	28.2	46	50	40	3°	57,000			
3600 00111150	-PHZ11S -150	1	11	150	82	1.5	18	26.5	46	50	40	3°	56,000			
3600 00111180	-180	2	11	180	112	—	18	28.2	46	50	40	3°	57,000			
3600 00112150	-PHZ12S -150	1	12	150	82	—	19	27.4	46	70	40	3°	1.1 56,000			
3600 00112180	-180	2	12	180	112	—	19	28.2	46	70	40	3°	57,000			
3600 00306150	BT40 -PHZ06S -150	1	6	150	82	1.5	13	21.5	46	37	29	3°	57,000			
3600 00306180	-180	1	6	180	112	1.5	13	24.6	46	37	29	3°	58,000			
3600 00307150	-PHZ07S -150	1	7	150	82	1.5	14	22.5	46	37	29	3°	57,000			
3600 00307180	-180	1	7	180	112	1.5	14	25.6	46	37	29	3°	58,000			
3600 00308150	-PHZ08S -150	1	8	150	82	1.5	15	23.5	46	50	29	3°	1.6 58,000			
3600 00308180	-180	1	8	180	112	1.5	15	26.6	46	50	29	3°	59,000			
3600 00309150	-PHZ09S -150	1	9	150	82	1.5	16	24.5	46	50	40	3°	58,000			
3600 00309180	-180	1	9	180	112	—	16	27.6	46	50	40	3°	59,000			
3600 00310150	-PHZ10S -150	1	10	150	82	1.5	17	25.5	46	50	40	3°	1.6 59,000			
3600 00310180	-180	2	10	180	112	—	17	28.2	46	50	40	3°	1.8 60,000			
3600 00311150	-PHZ11S -150	1	11	150	82	1.5	18	26.5	46	50	40	3°	59,000			
3600 00311180	-180	2	11	180	112	—	18	28.2	46	50	40	3°	60,000			
3600 00312150	-PHZ12S -150	1	12	150	82	—	19	27.4	46	70	40	3°	60,000			
3600 00312180	-180	2	12	180	112	—	19	28.2	46	70	40	3°	1.8 61,000			
3600 00506165	BT50 -PHZ06S -165	1	6	165	82	1.5	13	21.5	46	37	29	3°	4.2 59,000			
3600 00506195	-195	1	6	195	112	1.5	13	24.6	46	37	29	3°	60,000			
3600 00507165	-PHZ07S -165	1	7	165	82	1.5	14	22.5	46	37	29	3°	59,000			
3600 00507195	-195	1	7	195	112	1.5	14	25.6	46	37	29	3°	60,000			
3600 00508165	-PHZ08S -165	1	8	165	82	1.5	15	23.5	46	50	29	3°	4.2 60,000			
3600 00508195	-195	1	8	195	112	1.5	15	26.6	46	50	29	3°	4.3 61,000			
3600 00509165	-PHZ09S -165	1	9	165	82	1.5	16	24.5	46	50	40	3°	60,000			
3600 00509195	-195	1	9	195	112	—	16	27.6	46	50	40	3°	61,000			
3600 00510165	-PHZ10S -165	1	10	165	82	1.5	17	25.5	46	50	40	3°	61,000			
3600 00510195	-195	2	10	195	112	—	17	28.2	46	50	40	3°	62,000			
3600 00511165	-PHZ11S -165	1	11	165	82	1.5	18	26.5	46	50	40	3°	61,000			
3600 00511195	-195	2	11	195	112	—	18	28.2	46	50	40	3°	62,000			
3600 00512165	-PHZ12S -165	1	12	165	82	—	19	27.4	46	70	40	3°	4.2 62,000			
3600 00512195	-195	2	12	195	112	—	19	28.2	46	70	40	3°	4.4 63,000			

1. 刃物のシャンクは h6 公差範囲内のシャンクを使用してください。
2. ホルダを空締めしたまま放置しないでください。
3. センタースルークーラント供給時はエア抜き穴を付属の止めネジで塞いで下さい。
 1. Tool shank diameter tolerance must be within h6.
 2. Do not leave the holder with actuating screw tightened when the chuck is empty.
 3. Hex-head screws are necessary to plug air hole for center through coolant feed.



ご注文例 Ordering Example
BT30 - PHZ06S - 150
 シャンクサイズ Shank size
 突き出し長さ (L) Projection length

PHZ・S



スリムハイドロ "R" ゼロホルダ

Slim Hydro "R" Zero Holder

- スリムハイドロチャックに "R" ゼロ刃先振れ調整機能を追加。細穴奥の高精度加工などに最適。
Slim Hydro Chuck with "R" zero runout adjustment function. Suitable for high precision cutting in a deep/narrow hole.

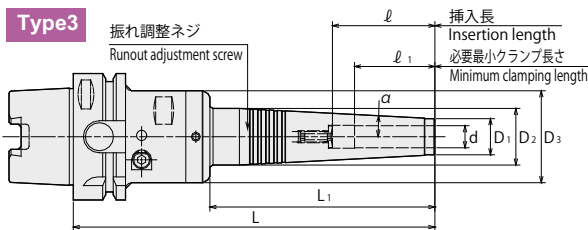
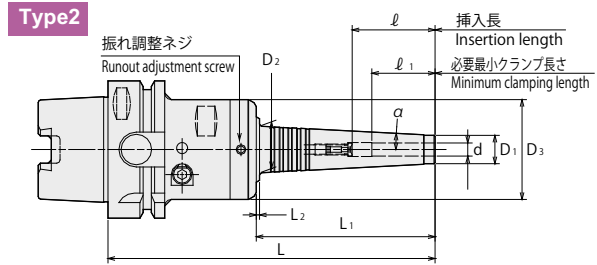
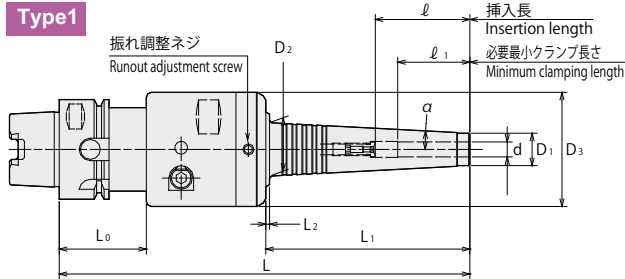

商品コード Code	型式 Model	Type	d	L	L ₁	L ₂	D ₁	D ₂	D ₃	L ₀	ℓ	ℓ ₁	α	Kg	—	締付レンチ(別売) Hex. wrench for the actuating screw (Option)	調整レンチ(付属) Hex. wrench for runout adjustment screw (Included)
5930 13006165	HSK40A -PHZ06S -165	1	6	165	82	1.5	13	21.5	46	35	37	29	3°	64,000		L-4T	L-3T-S
5930 13007165	-PHZ07S -165	1	7	165	82	1.5	14	22.5	46	35	37	29	3°	64,000			
5930 13008165	-PHZ08S -165	1	8	165	82	1.5	15	23.5	46	35	50	29	3°	65,000			
5930 13009165	-PHZ09S -165	1	9	165	82	1.5	16	24.5	46	35	50	40	3°	65,000			
5930 13010165	-PHZ10S -165	1	10	165	82	1.5	17	25.5	46	35	50	40	3°	66,000			
5930 13011165	-PHZ11S -165	1	11	165	82	1.5	18	26.5	46	35	50	40	3°	66,000			
5930 13012165	-PHZ12S -165	1	12	165	82	—	19	27.4	46	35	70	40	3°	67,000			
5930 15006150	HSK63A -PHZ06S -150	2	6	150	82	1.5	13	21.5	46	—	37	29	3°	1.3	67,000	L-4T	L-3T-S
5930 15006180	-180	2	6	180	112	1.5	13	24.6	46	—	37	29	3°	68,000			
5930 15007150	-PHZ07S -150	2	7	150	82	1.5	14	22.5	46	—	37	29	3°	67,000			
5930 15007180	-180	2	7	180	112	1.5	14	25.6	46	—	37	29	3°	68,000			
5930 15008150	-PHZ08S -150	2	8	150	82	1.5	15	23.5	46	—	50	29	3°	1.4	68,000		
5930 15008180	-180	2	8	180	112	1.5	15	26.6	46	—	50	29	3°	69,000			
5930 15009150	-PHZ09S -150	2	9	150	82	1.5	16	24.5	46	—	50	40	3°	68,000			
5930 15009180	-180	2	9	180	112	—	16	27.6	46	—	50	40	3°	69,000			
5930 15010150	-PHZ10S -150	2	10	150	82	1.5	17	25.5	46	—	50	40	3°	69,000			
5930 15010180	-180	3	10	180	112	—	17	28.2	46	—	50	40	3°	70,000			
5930 15011150	-PHZ11S -150	2	11	150	82	1.5	18	26.5	46	—	50	40	3°	69,000			
5930 15011180	-180	3	11	180	112	—	18	28.2	46	—	50	40	3°	70,000			
5930 15012150	-PHZ12S -150	2	12	150	82	—	19	27.4	46	—	70	40	3°	1.4	70,000		
5930 15012180	-180	3	12	180	112	—	19	28.2	46	—	70	40	3°	1.5	71,000		
5930 17006165	HSK100A -PHZ06S -165	2	6	165	82	1.5	13	21.5	46	—	37	29	3°	68,000	L-4T	L-3T-S	
5930 17006195	-195	2	6	195	112	1.5	13	24.6	46	—	37	29	3°	69,000			
5930 17007165	-PHZ07S -165	2	7	165	82	1.5	14	22.5	46	—	37	29	3°	68,000			
5930 17007195	-195	2	7	195	112	1.5	14	25.6	46	—	37	29	3°	69,000			
5930 17008165	-PHZ08S -165	2	8	165	82	1.5	15	23.5	46	—	50	29	3°	69,000			
5930 17008195	-195	2	8	195	112	1.5	15	26.6	46	—	50	29	3°	70,000			
5930 17009165	-PHZ09S -165	2	9	165	82	1.5	16	24.5	46	—	50	40	3°	69,000			
5930 17009195	-195	2	9	195	112	—	16	27.6	46	—	50	40	3°	70,000			
5930 17010165	-PHZ10S -165	2	10	165	82	1.5	17	25.5	46	—	50	40	3°	70,000			
5930 17010195	-195	3	10	195	112	—	17	28.2	46	—	50	40	3°	71,000			
5930 17011165	-PHZ11S -165	2	11	165	82	1.5	18	26.5	46	—	50	40	3°	70,000			
5930 17011195	-195	3	11	195	112	—	18	28.2	46	—	50	40	3°	71,000			
5930 17012165	-PHZ12S -165	2	12	165	82	—	19	27.4	46	—	70	40	3°	71,000			
5930 17012195	-195	3	12	195	112	—	19	28.2	46	—	70	40	3°	72,000			

1. 刃物のシャンクは h6 公差範囲内のシャンクを使用してください。
 2. ホルダを空締めしたまま放置しないでください。
1. Tool shank diameter tolerance must be within h6.
 2. Do not leave the holder with actuating screw tightened when the chuck is empty.

ご注文例 Ordering Example

HSK40A - PHZ06S - 165

シャンクサイズ
Shank size

突き出し長さ (L)
Projection length

レンチ
Wrench
P. 89

