

HCL

HSK Clamper

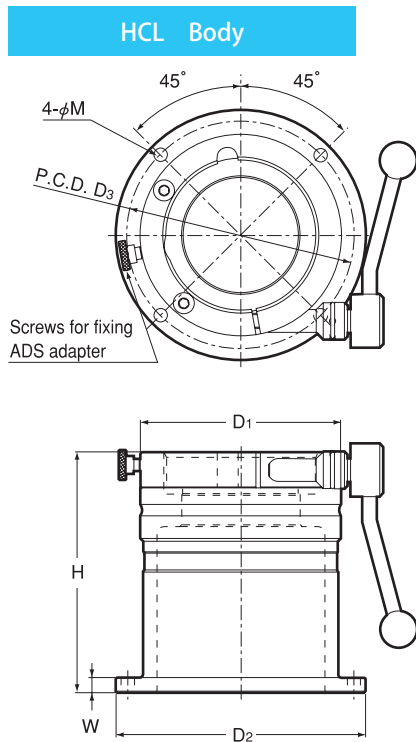

ADS (option) Adapter

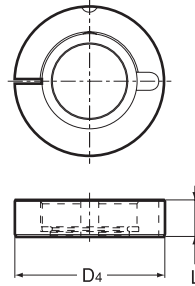

Body only



Body + Adapter



Application / Feature

1. Best suited for tightening milling chucks or collet chucks.
2. All types of HSK(A-F, and T) and UTS can be clamped.
3. With ADS adapters, various different shanks can be clamped.
4. Tool holder can be clamped by turning the clamp lever only. The clamp lever can be turned in either direction.
5. ABS resins will prevent damages to taper or flange face of HSK/UTS shank.

Body

Code	Model	Shank size	D1	H	D2	D3	W	M	kg	Adapter
5590 06300000	HCL -63	HSK63, UTS6350	98	162	131	115	10	9 (For M8)	4.6	ADS-63 * *
5590 10000000	HCL -100	HSK100, UTS10080	135	162	168	152	10	9 (For M8)	7.0	ADS-100 * *

- ※ Do not use for measuring tool presetting length.
- ※ Fixing bolts (4pcs) for installing to surface plate or work table are NOT included.

Adapter

Model	Code	Shank size	D4	L	kg	Body
ADS -6325	5590 06325000	HSK25	63	24.2	0.5	HCL-63
ADS -6332	5590 06332000	HSK32	63	24.2	0.4	HCL-63
ADS -6340	5590 06340000	HSK40	63	24.2	0.3	HCL-63
ADS -6350	5590 06350000	HSK50, UTS5040	63	24.2	0.2	HCL-63
ADS -10063	5590 10063000	HSK63, UTS6350	100	24.2	0.9	HCL-100
ADS -10080	5590 10080000	HSK80	100	24.2	0.6	HCL-100

Body

Ordering Example

HCL - 63
Shank size

Adapter

Ordering Example

ADS - 63 50
Body size Shank size