

# SPZ-2

"R" Zero Setter

- BT
- CAT
- AHO
- HSK-A/E/F/C
- HSK-T
- UTS
- Specialized Machine
- Related Equipment
- Bush & Chamfering Drill
- Spanner Head Torque Wrench

Metric only

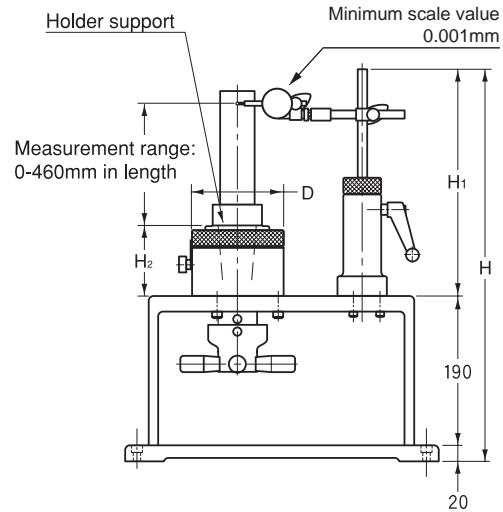
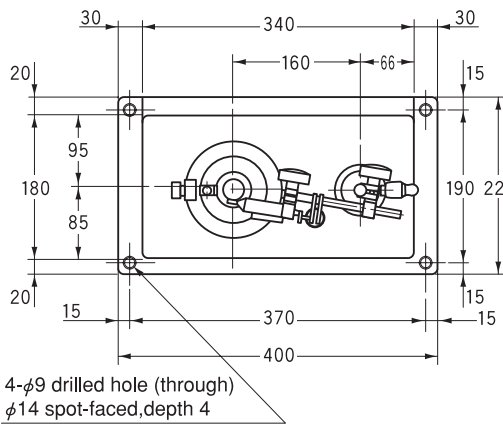

## Feature

1. Less than 3  $\mu$ m runout accuracy at 200mm(HSK, UTS)
2. Rotary holder support for BT, HSK, UTS.
3. Holder pull-in mechanism.

| Code          | Model           | Holder support    | D   | H   | H1  | H2  | kg | Retention stud  |
|---------------|-----------------|-------------------|-----|-----|-----|-----|----|-----------------|
| 3030 00003011 | SPZ-2 -NT30-1   | NT30              | 118 | 660 | 450 | 90  | 39 | BT:MAS I MAS II |
| 3030 00004011 | SPZ-2 -NT40-1   | NT40              | 118 | 660 | 450 | 90  | 39 | BT:MAS I MAS II |
| 3030 00005011 | SPZ-2 -NT50-1   | NT50              | 158 | 710 | 500 | 120 | 46 | BT:MAS I MAS II |
| 3030 00003012 | SPZ-2 -NT30-2   | NT30              | 118 | 660 | 450 | 90  | 39 | BT:JIS SK:DIN   |
| 3030 00004012 | SPZ-2 -NT40-2   | NT40              | 118 | 660 | 450 | 90  | 39 | BT:JIS SK:DIN   |
| 3030 00005012 | SPZ-2 -NT50-2   | NT50              | 158 | 710 | 500 | 120 | 46 | BT:JIS SK:DIN   |
| 3030 10004010 | SPZ-2 -HSK40    | HSK40A, HSK40C    | 118 | 660 | 450 | 90  | 40 |                 |
| 3030 10005010 | SPZ-2 -HSK50    | HSK50A, HSK50C    | 118 | 660 | 450 | 90  | 40 |                 |
| 3030 10006310 | SPZ-2 -HSK63    | HSK63A, HSK63C    | 118 | 660 | 450 | 90  | 39 |                 |
| 3030 10010010 | SPZ-2 -HSK100   | HSK100A, HSK100C  | 158 | 710 | 500 | 120 | 49 |                 |
| 3030 20635010 | SPZ-2 -UTS6350  | UTS6350, (HS63)   | 118 | 660 | 450 | 90  | 39 |                 |
| 3030 21008010 | SPZ-2 -UTS10080 | UTS10080, (HS100) | 158 | 710 | 500 | 120 | 48 |                 |

- ※ Master shank is sold separately.
- ※ Retention stud with 90 degree pull-in angle (the angle of the part hooked by jaw) is not capable.
- ※ Metric measurement only.

## Ordering Example

**SPZ-2 - NT30 - 1**

Retention size  
Holder Support

Shrink Fit System

Digital measuring equipment reference position

Tool Presetter

HSK Clamper

"R" Zero Setter

Simple Setter