

SPT

Simple Setter For Tr Shank

- BT
- CAT
- AHO
- HSK-A/E/F/C
- HSK-T
- UTS
- Specialized Machine
- Related Equipment
- Bush & Chamfering Drill
- Spanner Head Torque Wrench
- Shrink Fit System
- Digital measuring equipment reference position
- Tool Presetter
- HSK Clamper
- "R" Zero Setter
- Simple Setter

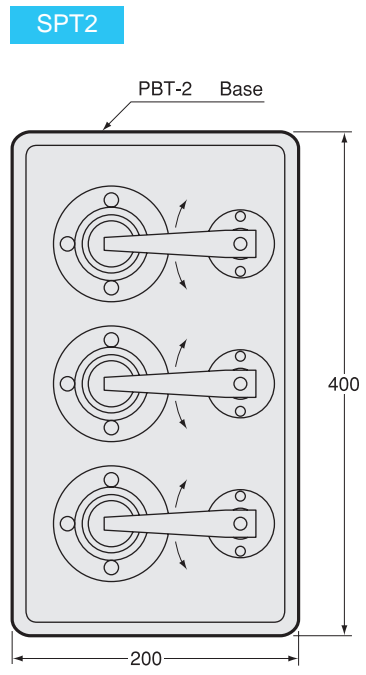
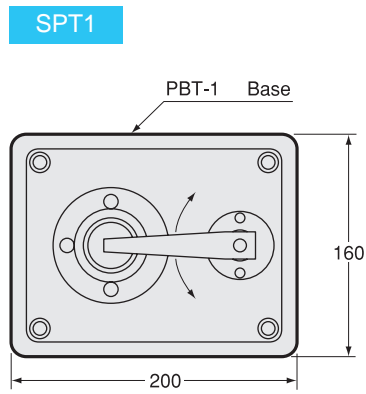
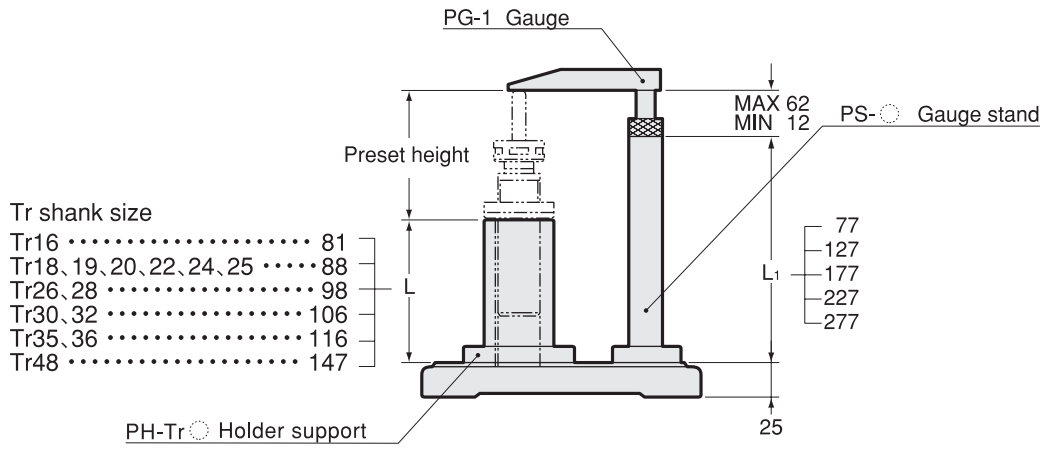

Gauge	Gauge stand	Holder support	Base
PG-1	PS-	PH-Tr	PBT-1 PBT-2

Ordering Example

SPT1 - Tr16X5 - 77

Base PBT-1 Holder Support Gauge stand height L1

Code

0090 4 1 16 5 077

Base PBT-1 | Tr-16 | Gauge stand height L1
Key width 5

Guage PG

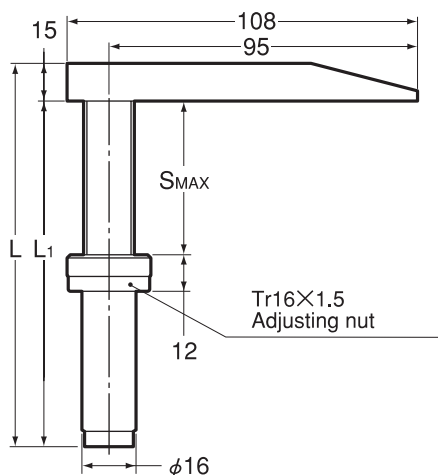

Code	Model	L	L1	SMAX	kg
0091 06000001	PG-1	128	113	50	0.4

Guage stand PS

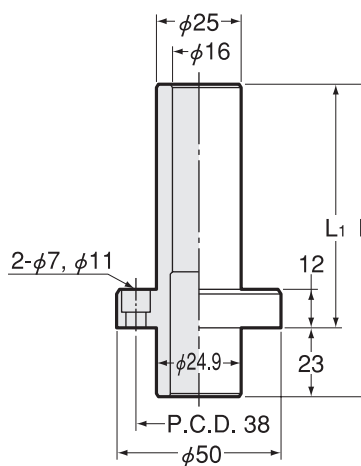

Code	Model	L	L1
0091 01000001	PS -1	100	77
0091 01000002	PS -2	150	127
0091 01000003	PS -3	200	177
0091 01000004	PS -4	250	227
0091 01000005	PS -5	300	277

Holder support PH-Tr

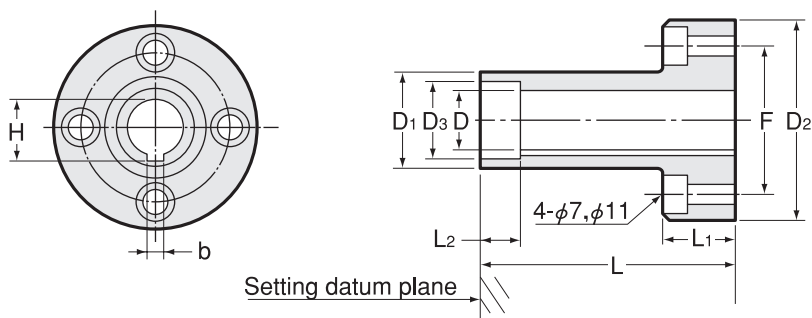

※ PH-Tr22x5 have Tr nut type and SSMA nut type respectively. Please specify when you place an order.

Code	Model	D	D1	D2	D3	L	L1	L2	F	b	H
0091 05000163	PH -Tr16x3	16	24	50	20.5	81	20	10.5	36	3	17.5
0091 05000164	PH -Tr16x4	16	24	50	20.5	81	20	10.5	36	4	17.7
0091 05000165	PH -Tr16x5	16	24	50	20.5	81	20	10.5	36	5	17.5
0091 05000184	PH -Tr18x4	18	32	60	22.5	88	20	12	45	4	20
0091 05000195	PH -Tr19x5	19	32	60	26	88	20	12	45	5	21.5
0091 05000205	PH -Tr20x5	20	32	60	26	88	20	13	45	5	22.5
0091 05000225	PH -Tr22x5	22	33	60	(29.5)	88	20	13	45	5	24.5
0091 05000245	PH -Tr24x5	24	38	65	32.5	88	20	13	51	5	26.5
0091 05000256	PH -Tr25x6	25	38	65	32.5	88	20	13	51	6	27
0091 05000265	PH -Tr26x5	26	39	65	34.5	98	20	13	51	5	28.5
0091 05000267	PH -Tr26x7	26	39	65	34.5	98	20	13	51	7	29.5
0091 05000285	PH -Tr28x5	28	39	65	34.5	98	20	13	51	5	30.5
0091 05000286	PH -Tr28x6	28	39	65	34.5	98	20	13	51	6	30
0091 05000307	PH -Tr30x7	30	50	76	44	106	20	17	62	7	33.5
0091 05000326	PH -Tr32x6	32	50	76	38.5	106	20	14.5	62	6	35
0091 05000328	PH -Tr32x8	32	50	76	38.5	106	20	14.5	62	8	34
0091 05000356	PH -Tr35x6	35	50	76	44	116	20	17	62	6	37
0091 05000357	PH -Tr35x7	35	50	76	44	116	20	17	62	7	38.5
0091 05000368	PH -Tr36x8	36	50	76	44	116	20	17	62	8	38
0091 05003610	PH -Tr36x10	36	50	76	44	116	20	17	62	10	40
0091 05000487	PH -Tr48x7	48	67	100	58.5	147	20	21	83	7	51.5
0091 05000488	PH -Tr48x8	48	67	100	58.5	147	20	21	83	8	50.5
0091 05004810	PH -Tr48x10	48	67	100	58.5	147	20	21	83	10	50.5
0091 05004812	PH -Tr48x12	48	67	100	58.5	147	20	21	83	12	52

- BT
- CAT
- AHO
- HSK-A/E/F/C
- HSK-T
- UTS
- Specialized Machine
- Related Equipment
- Bush & Chamfering Drill

- Spanner Head Torque Wrench

- Shrink Fit System

- Digital measuring equipment reference position

- Tool Presetter

- HSK Clamper

- "R" Zero Setter

- Simple Setter

Base PBT

TYPE1

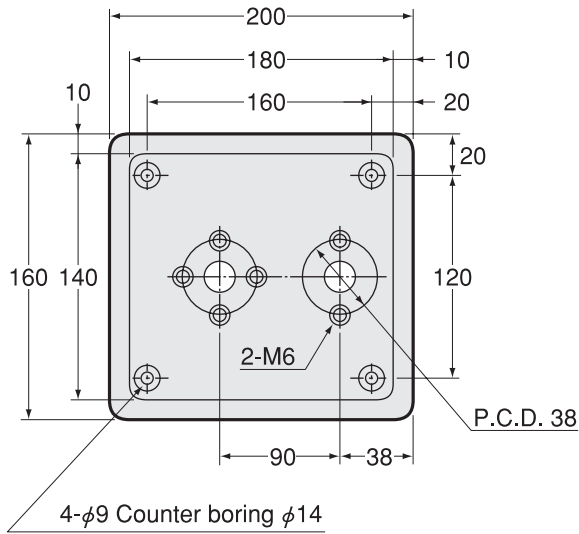

TYPE2

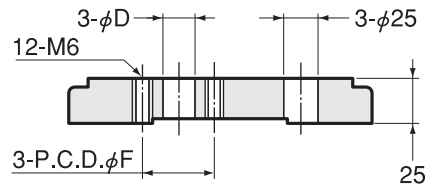
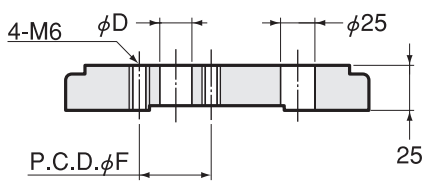
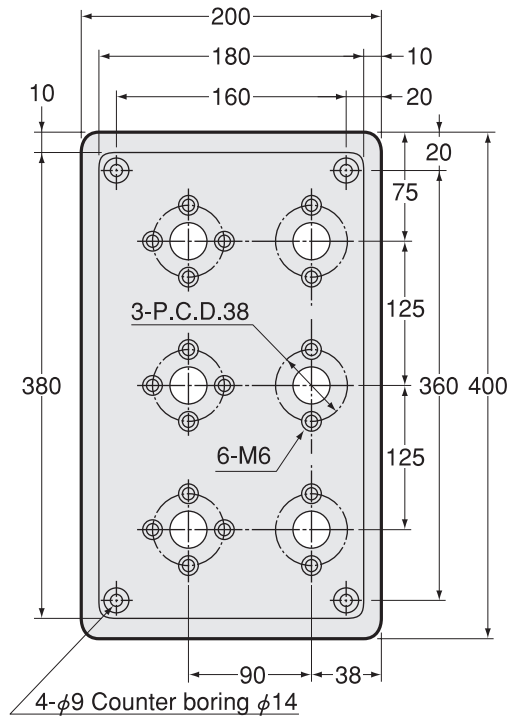

Code	Model	Type	φ F	φ D	Holder support	Gauge stand
0091 07200136	PBT -1-36	1	36	17	PH-Tr16	PS-1 ~ PS-5
0091 07200236	PBT -2-36	2	36	17	PH-Tr16	PS-1 ~ PS-5
0091 07200145	PBT -1-45	1	45	23	PH-Tr18 ~ 22	PS-1 ~ PS-5
0091 07200245	PBT -2-45	2	45	23	PH-Tr18 ~ 22	PS-1 ~ PS-5
0091 07200151	PBT -1-51	1	51	31	PH-Tr24 ~ 28	PS-1 ~ PS-5
0091 07200251	PBT -2-51	2	51	31	PH-Tr24 ~ 28	PS-1 ~ PS-5
0091 07200162	PBT -1-62	1	62	37	PH-Tr30 ~ 36	PS-1 ~ PS-5
0091 07200262	PBT -2-62	2	62	37	PH-Tr30 ~ 36	PS-1 ~ PS-5
0091 07200183	PBT -1-83	1	83	56	PH-Tr48	PS-1 ~ PS-5
0091 07200283	PBT -2-83	2	83	56	PH-Tr48	PS-1 ~ PS-5