

ERC-T

Collet Holder For Small Diameters (Taper Type)

- For drilling in tight space.

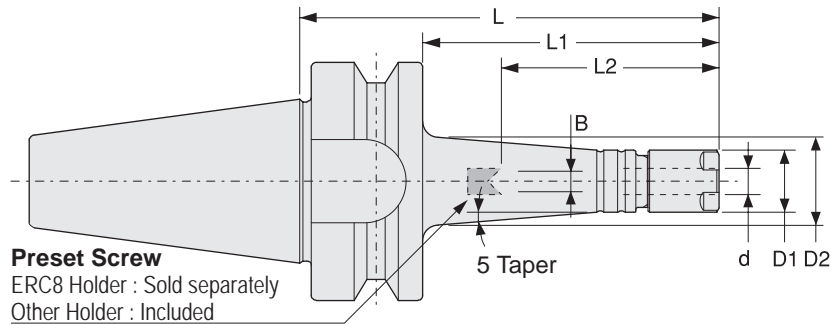

Unit : Metric

Code	Model	d	L	L1	B	L2	D1	D2	Nut	Collet	Spanner
2550 10108060	BT30 -ERC8* -60T	0.5 ~ 5.0	60	38	— (0 ~ 2.4)	³⁴ (19 ~ 31)	12	14.5	ERP-8	ER8	S-8E
2550 10108075	-75T	0.5 ~ 5.0	75	53	— (0 ~ 2.4)	³⁴ (19 ~ 31)	12	17.5	ERP-8		
2550 10108090	-90T	0.5 ~ 5.0	90	68	— (0 ~ 2.4)	³⁴ (19 ~ 31)	12	20	ERP-8		
2550 10108105	-105T	0.5 ~ 5.0	105	83	— (0 ~ 2.4)	³⁴ (19 ~ 31)	12	22.5	ERP-8		
2550 10108135	-135T	0.5 ~ 5.0	135	113	— (0 ~ 2.4)	³⁴ (19 ~ 31)	12	28	ERP-8		
2550 10110060	BT30 -ERC11S -60T	0.5 ~ 7.0	60	38	0 ~ 4	22 ~ 45	16	18.5	ERP-11S	ER11	S-11E
2550 10110075	-75T	0.5 ~ 7.0	75	53	0 ~ 4	22 ~ 45	16	21	ERP-11S		
2550 10110090	-90T	0.5 ~ 7.0	90	68	0 ~ 4	22 ~ 45	16	24	ERP-11S		
2550 10110105	-105T	0.5 ~ 7.0	105	83	0 ~ 4	22 ~ 45	16	26.5	ERP-11S		
2550 10110135	-135T	0.5 ~ 7.0	135	113	0 ~ 4	22 ~ 45	16	31.5	ERP-11S		
2550 10308060	BT40 -ERC8 -60T	0.5 ~ 5.0	60	33	— (0 ~ 2.4)	³⁴ (19 ~ 31)	12	14	ERP-8	ER8	S-8E
2550 10308075	-75T	0.5 ~ 5.0	75	48	— (0 ~ 2.4)	³⁴ (19 ~ 31)	12	16.5	ERP-8		
2550 10308090	-90T	0.5 ~ 5.0	90	63	— (0 ~ 2.4)	³⁴ (19 ~ 31)	12	19	ERP-8		
2550 10308105	-105T	0.5 ~ 5.0	105	78	— (0 ~ 2.4)	³⁴ (19 ~ 31)	12	21.5	ERP-8		
2550 10308135	-135T	0.5 ~ 5.0	135	108	— (0 ~ 2.4)	³⁴ (19 ~ 31)	12	27	ERP-8		
2550 10310060	BT40 -ERC11S -60T	0.5 ~ 7.0	60	33	0 ~ 4	22 ~ 45	16	17.5	ERP-11S	ER11	S-11E
2550 10310075	-75T	0.5 ~ 7.0	75	48	0 ~ 4	22 ~ 45	16	20.5	ERP-11S		
2550 10310090	-90T	0.5 ~ 7.0	90	63	0 ~ 4	22 ~ 45	16	23	ERP-11S		
2550 10310105	-105T	0.5 ~ 7.0	105	78	0 ~ 4	22 ~ 45	16	25.5	ERP-11S		
2550 10310135	-135T	0.5 ~ 7.0	135	108	0 ~ 4	22 ~ 45	16	31	ERP-11S		

1. Collet and spanner are sold separately.
2. *ES8, a preset screw for ERC8, is sold separately. ERC11S includes a standard preset screw HDS-07A-ES11.
3. " B " and " L2 " dimensions in brackets are for using ES8 preset screw.
4. Refer to P. 092 for minimum tool insertion length in case of using our coolant collets.
5. See P.499 for standard Tightening Torque.

Collet

P. 090-091



Spanner

P. 095



Preset screw

P. 094



Ordering Example

BT40 - ERC 8 - 105 T
 Shank size Max. collet I.D. Projection length (L)

ERC-T

Collet Holder For Small Diameters (Taper Type)

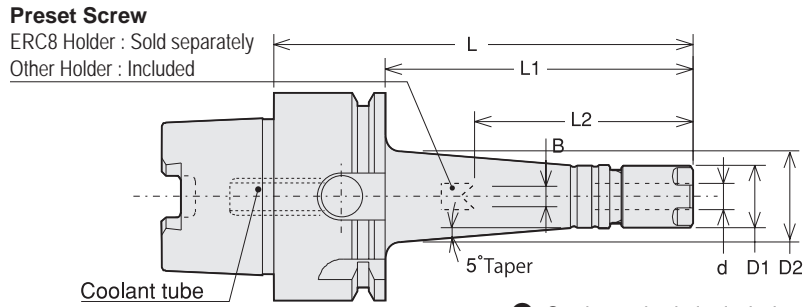

- For drilling in tight space.



Unit : Metric

Code	Model	d	L	L1	B	L2	D1	D2	Nut	kg	Collet	Spanner
5370 01308060	HSK40A -ERC8 -60T	0.5 ~ 5.0	60	40	—	34	12	15	ERP-8	0.3	ER8	S-8E
5370 01308075	-75T	0.5 ~ 5.0	75	55	(0 ~ 2.4)	³⁴ (19 ~ 31)	12	17.5	ERP-8	0.3		
5370 01308090	-90T	0.5 ~ 5.0	90	70	(0 ~ 2.4)	³⁴ (19 ~ 31)	12	20.5	ERP-8	0.3		
5370 01308105	-105T	0.5 ~ 5.0	105	85	(0 ~ 2.4)	³⁴ (19 ~ 31)	12	23	ERP-8	0.4		
5370 01310060	HSK40A -ERC11S -60T	0.5 ~ 7.0	60	40	0 ~ 4	22 ~ 24	16	19	ERP-11S	0.3	FDC-07	S-11E
5370 01310075	-75T	0.5 ~ 7.0	75	55	0 ~ 4	22 ~ 38	16	21.5	ERP-11S	0.4		
5370 01310090	-90T	0.5 ~ 7.0	90	70	0 ~ 4	22 ~ 45	16	24	ERP-11S	0.4		
5370 01310090	-105T	0.5 ~ 7.0	105	85	0 ~ 4	22 ~ 45	16	26.5	ERP-11S	0.4		
5370 01408075	HSK50A -ERC8 -75T	0.5 ~ 5.0	75	49	(0 ~ 2.4)	³⁴ (19 ~ 30)	12	16.5	ERP-8	0.5	ER8	S-8E
5370 01408090	-90T	0.5 ~ 5.0	90	64	(0 ~ 2.4)	³⁴ (19 ~ 31)	12	19.5	ERP-8	0.5		
5370 01408105	-105T	0.5 ~ 5.0	105	79	(0 ~ 2.4)	³⁴ (19 ~ 31)	12	22	ERP-8	0.5		
5370 01410075	HSK50A -ERC11S -75T	0.5 ~ 7.0	75	49	0 ~ 4	22 ~ 32	16	20.5	ERP-11S	0.6	FDC-07	S-11E
5370 01410090	-90T	0.5 ~ 7.0	90	64	0 ~ 4	22 ~ 45	16	23	ERP-11S	0.6		
5370 01410105	-105T	0.5 ~ 7.0	105	79	0 ~ 4	22 ~ 45	16	25.5	ERP-11S	0.7		
5370 01508060	HSK63A -ERC8 -60T	0.5 ~ 5.0	60	34	—	34	12	14	ERP-8	0.7	ER8	S-8E
5370 01508075	-75T	0.5 ~ 5.0	75	49	(0 ~ 2.4)	³⁴ (19 ~ 28)	12	16.5	ERP-8	0.8		
5370 01508090	-90T	0.5 ~ 5.0	90	64	(0 ~ 2.4)	³⁴ (19 ~ 31)	12	19.5	ERP-8	0.8		
5370 01508105	-105T	0.5 ~ 5.0	105	79	(0 ~ 2.4)	³⁴ (19 ~ 31)	12	22	ERP-8	0.8		
5370 01508120	-120T	0.5 ~ 5.0	120	94	(0 ~ 2.4)	³⁴ (19 ~ 31)	12	24.5	ERP-8	0.9		
5370 01508135	-135T	0.5 ~ 5.0	135	109	(0 ~ 2.4)	³⁴ (19 ~ 31)	12	27	ERP-8	0.9		
5370 01510060	HSK63A -ERC11S -60T	0.5 ~ 7.0	60	34	—	22 ~ 24	16	18	ERP-11S	0.7	FDC-07	S-11E
5370 01510075	-75T	0.5 ~ 7.0	75	49	0 ~ 4	22 ~ 38	16	20.5	ERP-11S	0.8		
5370 01510090	-90T	0.5 ~ 7.0	90	64	0 ~ 4	22 ~ 45	16	23	ERP-11S	0.8		
5370 01510105	-105T	0.5 ~ 7.0	105	79	0 ~ 4	22 ~ 45	16	25.5	ERP-11S	0.9		
5370 01510120	-120T	0.5 ~ 7.0	120	94	0 ~ 4	22 ~ 45	16	28.5	ERP-11S	0.9		
5370 01510135	-135T	0.5 ~ 7.0	135	109	0 ~ 4	22 ~ 45	16	31	ERP-11S	1.0		

1. Collet and spanner are sold separately.
2. ES8, a preset screw for ERC8-T, is sold separately. ERC11S-T includes a standard preset screw HDS-07A-ES11.
3. " B " and " L2 " dimensions in brackets are for using ES8 preset screw.
4. Refer to P.092 for minimum tool insertion length in case of using our coolant collets.
5. See P.499 for standard Tightening Torque.

Collet P. 090-091 	Spanner P. 095 	Preset screw P. 094 
--	---	--

Ordering Example

HSK40A - ERC 8 - 105 T
 Shank size Max. collet I.D. Projection length (L)

ERC-T

Collet Holder For Small Diameters (Taper Type)

- For drilling in tight space.

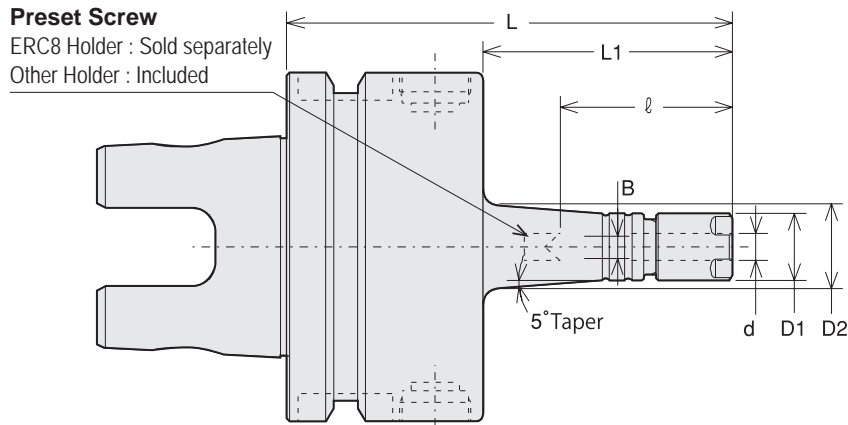

Unit : Metric

Code	Model	d	L	L1	B	l	D1	D2	Nut	Collet	Spanner
1340 11108075	UTS5040 -ERC8 -75TH	0.5 ~ 5.0	75	45	— (0 ~ 2.4)	³⁴ (19 ~ 24)	12	16	ERP-8	ER8	S-8E
1340 11108105	-105TH	0.5 ~ 5.0	105	75	— (0 ~ 2.4)	³⁴ (19 ~ 31)	12	21	ERP-8	ER8	S-8E
1340 11110075	UTS5040 -ERC11S -75TH	0.5 ~ 7.0	75	45	0 ~ 4	22 ~ 32	16	19.5	ERP-11S	ER11	S-11E
1340 11110105	-105TH	0.5 ~ 7.0	105	75	0 ~ 4	22 ~ 45	16	25	ERP-11S	ER11	S-11E
1340 1 ※ 208075	UTS6350 -ERC8 -75T	0.5 ~ 5.0	75	42	— (0 ~ 2.4)	³⁴ (19 ~ 24)	12	15.5	ERP-8	ER8	S-8E
1340 1 ※ 208105	-105T	0.5 ~ 5.0	105	72	— (0 ~ 2.4)	³⁴ (19 ~ 31)	12	20.5	ERP-8	ER8	S-8E
1340 1 ※ 210075	UTS6350 -ERC11S -75T	0.5 ~ 7.0	75	42	0 ~ 4	22 ~ 34	16	19	ERP-11S	ER11	S-11E
1340 1 ※ 210105	-105T	0.5 ~ 7.0	105	72	0 ~ 4	22 ~ 45	16	24.5	ERP-11S	ER11	S-11E

When placing an order, please specify high or low pressure. For high pressure type, please add (-H) on end of the description.

1. Collet and spanner are sold separately.
2. ES8, a preset screw for ERC8-T, is sold separately. ERC11S-T includes a standard preset screw HDS-07A-ES11.
3. "B" and "l" dimensions in brackets are for using ES8 preset screw.
4. Refer to P.092 for minimum tool insertion length in case of using our coolant collets.
5. UTS5040 is available in high pressure only.
6. See P.499 for standard Tightening Torque.

<p>Collet</p> <p>P. 090-091</p> 	<p>Spanner</p> <p>P. 095</p> 	<p>Preset screw</p> <p>P. 094</p> 
---	--	---

Ordering Example

Low pressure type

0 ~ 1.0MPa (UTS10080 : 0 ~ 2.0MPa)

UTS6350 - ERC 8 - 105 T

Shank size Max. collet I.D. Projection length (L)

Ordering Example

High pressure type

1.1 ~ 7.0MPa (UTS10080 : 2.1 ~ 7.0MPa)

UTS6350 - ERC 8 - 105 T - H

Shank size Max. collet I.D. Projection length (L) High pressure type