

## SIMPLE SETTER

Expensive all purpose tool presettors are widely available in the market. However, customers have been spending a lot of time and money to make presettors for projection length of cutting tool.

NT's simple setter provides preset gauge suitable for customers needs.







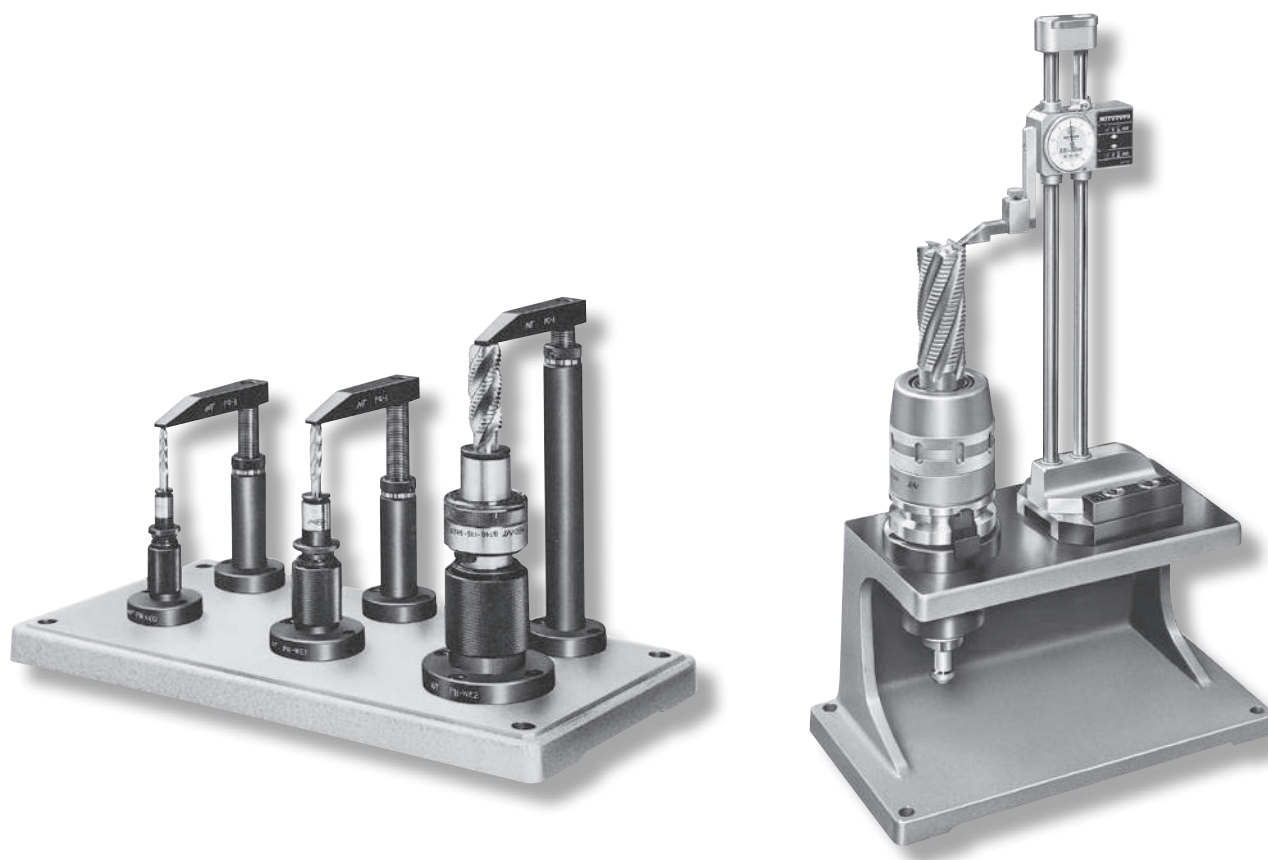

### Application

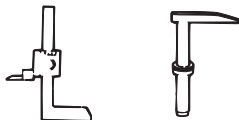
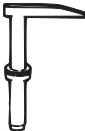

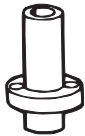

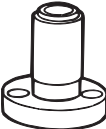
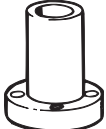
- Tool presetting for the use on machining centers and dedicated machines.

### Feature

- Wide variety of types and sizes
- Quick-to-built-up preset gauge

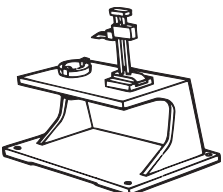
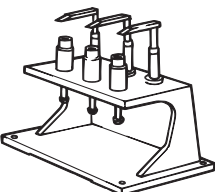
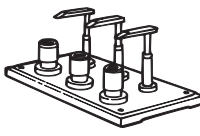
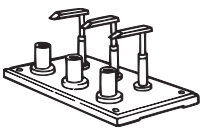

	For NC Toolings	For NT stub holders	For tap adapters	For Tr. shank
Gauge	<p>Height gauge</p>  <p>conventional</p> <p>PG-1</p>		 <p>PG-1</p>	
Gauge stand	 <p>PS-H4</p> <p>PS-0</p>		 <p>PS-0</p>	
Holder support	 <p>PH-NT</p>	 <p>PH-STC PH-K PH-KH</p>	 <p>PH-WE</p>	 <p>PH-Tr</p>
Base	 <p>PBN-1</p> <p>PBN-2</p>	 <p>PBK-1</p> <p>PBK-2</p>	 <p>PBT-1</p>	 <p>PBT-2</p>

Set-up	 <p>SPN1-NT</p> <p>Break-down: PG-1, PS-0, PH-NT, PBN-1 (1pc each)</p>	 <p>SPK1-K</p> <p>Break-down: PG-1, PS-0, PH-K, PBK-1 (1pc each)</p>	 <p>SPW1-WE</p> <p>Break-down: PG-1, PS-0, PH-WE, PBT-1 (1pc each)</p>	 <p>SPT1-Tr</p> <p>Break-down: PG-1, PS-0, PH-Tr, PBT-1 (1pc each)</p>
	 <p>SPN2-NT + Existing Height gauge</p> <p>Break-down: PS-H4, PH-NT, PBN-2 (1pc each)</p>	 <p>SPK2-K</p> <p>Break-down: PG-1, PS-0, PH-K, PBK-2 (3pcs each), PBK-2 (1pc)</p>	 <p>SPW2-WE</p> <p>Break-down: PG-1, PS-0, PH-WE, PBT-2 (3pcs each), PBT-2 (1pc)</p>	 <p>SPT2-Tr</p> <p>Break-down: PG-1, PS-0, PH-Tr, PBT-2 (3pcs each), PBT-2 (1pc)</p>

BT  
CAT  
AHO  
HSK-A/E/F/C  
HSK-T  
UTS  
Specialized Machine  
Related Equipment  
Bush & Chamfering Drill

Spanner Head Torque Wrench

Shrink Fit System

Digital measuring equipment of reference position

Tool Presetter

HSK Clamper

"R" Zero Setter

Simple Setter

# SPN

Simple Setter For NC Tooling

BT  
CAT  
AHO  
HSK-A/E/F/C  
HSK-T  
UTS  
Specialized Machine  
Related Equipment  
Bush & Chamfering Drill  
Spanner Head Torque Wrench





Shrink Fit System  
Digital measuring equipment of reference position

Tool Presetter  
HSK Clamper

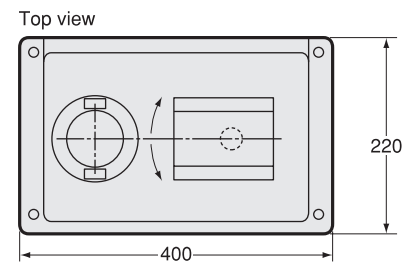
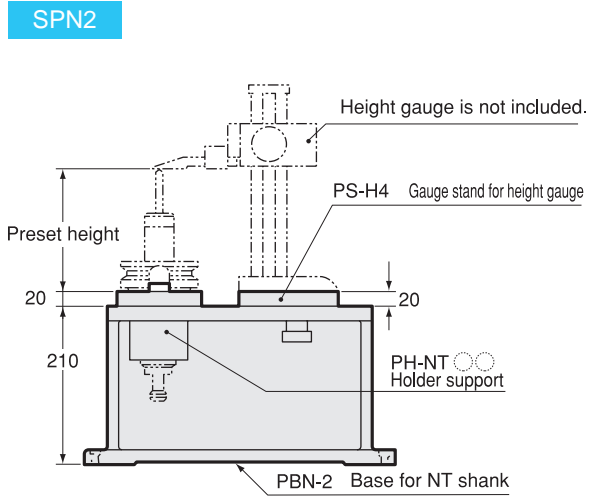
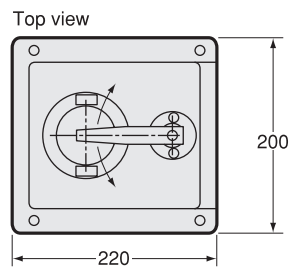
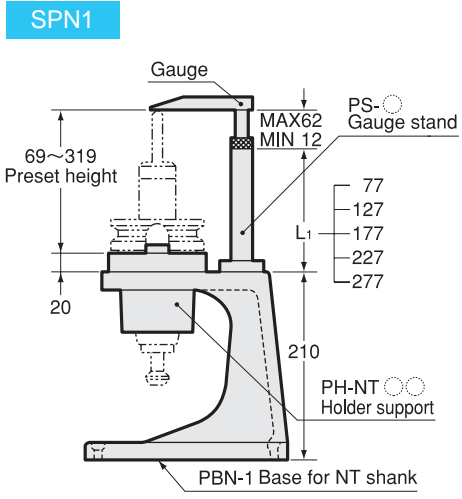
"R" Zero Setter

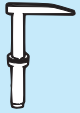
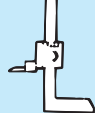
Simple Setter

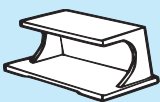

Gauge	Gauge stand	Holder support	Base
 PG-1	 conventional	 PS-○	 PS-H4
		 PH-NT ○	 PBN-1 ○
			 PBN-2 ○

**Ordering Example**  
**SPN1 - NT40 - 227**  
 Base PBN-1    Holder Support    Gauge stand height L1

**Ordering Example**  
**SPN2 - NT40 + PS-H4**  
 Base PBN-2    Holder Support    Gauge stand

**Code**  
**0090 01 1 0 4 227**  
 Base PBN-1    Holder Support    Gauge stand height L1

**Code**  
**0090 01 2 0 4 4 00**  
 Base PBN-2    Holder Support    Gauge stand PS-H4

Product code for each holder support is as follows. NT 30=1, NT 35=2, NT 40=4, NT 45=5 and NT 50=6.

PG  
Guage

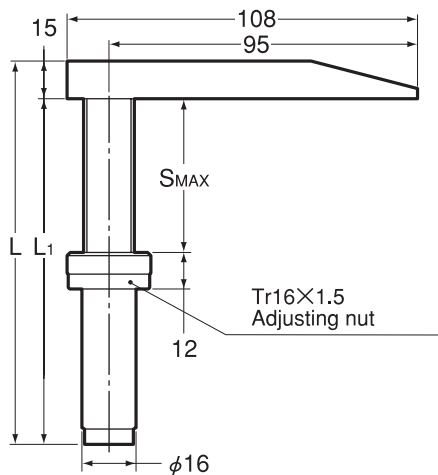

PS  
Guage stand

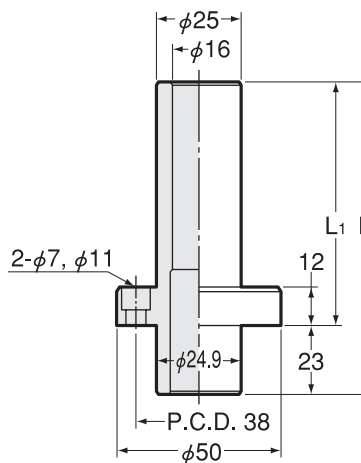

Code	Model	L	L1	SMAX	kg
0091 06000001	<b>PG-1</b>	128	113	50	0.4

Code	Model	L	L1
0091 01000001	<b>PS -1</b>	100	77
0091 01000002	<b>PS -2</b>	150	127
0091 01000003	<b>PS -3</b>	200	177
0091 01000004	<b>PS -4</b>	250	227
0091 01000005	<b>PS -5</b>	300	277

Gauge stand for height gauge

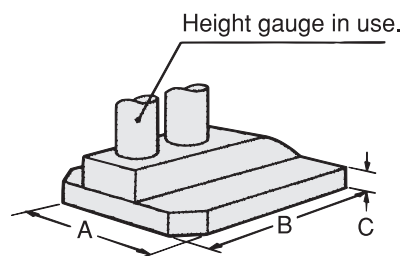
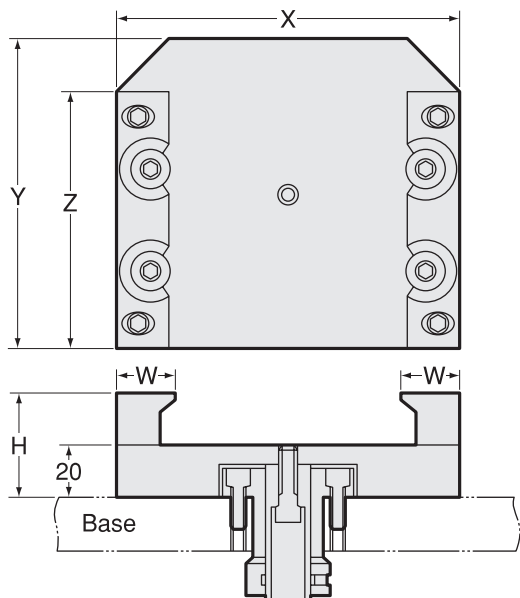

Code	Model	X	Y	Z	W	H	A	B	C
0091 01100004	<b>PS-H4</b>	136	135	110	21	37	91	135	12

- When ordering special gauge stand, please let us know base dimensions A x B x C.
- PS-H4 is used for Mitutoyo height gauge HD-30AX(192-613-10) or HW-30(192-130).

Holder support PH-NT

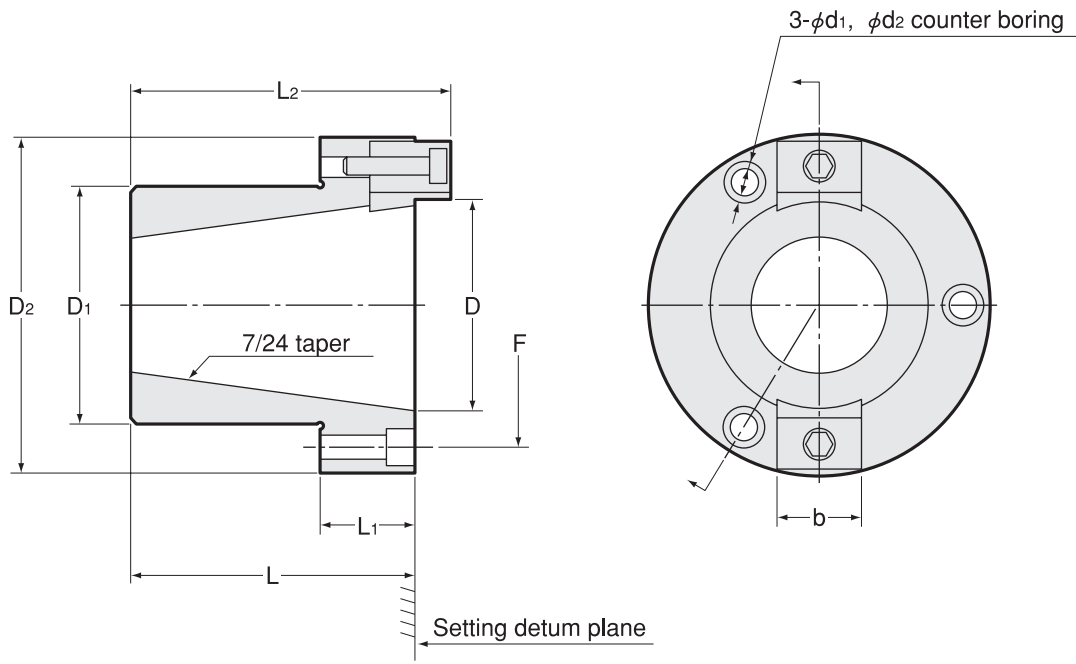

Code	Model	Shank size			D	D1	D2	L	L1	L2	F	b	d1	d2	kg
0091 02000030	<b>PH -NT30</b>	BT30	CAT30	SK30	31.75	48	74	45	20	52	59	15.7	7	11	0.9
0091 02000035	<b>PH -NT35</b>	BT35	—	—	38.1	48	74	50	20	57	59	13.8	7	11	0.8
0091 02000040	<b>PH -NT40</b>	BT40	CAT40	SK40	44.45	54	80	55	20	62	65	15.7	7	11	1.0
0091 02000045	<b>PH -NT45</b>	BT45	—	SK45	57.15	68	100	75	20	85	81	18.9	9	14	1.8
0091 02000050	<b>PH -NT50</b>	BT50	CAT50	SK50	69.85	78	110	90	20	100	92	25.3	9	14	2.3

To set CAT or SK shank holder, remove one of the stopper keys on the holder support PH-NT.

BT  
CAT  
AHO  
HSK-A/E/F/C  
HSK-T  
UTS  
Specialized Machine

Related Equipment  
Bush & Chamfering Drill

Spanner Head  
Torque Wrench

Shrink Fit System

Digital measuring equipment  
reference position

Tool Presetter

HSK Clamper

"R" Zero Setter

Simple Setter

Base PBN

TYPE1

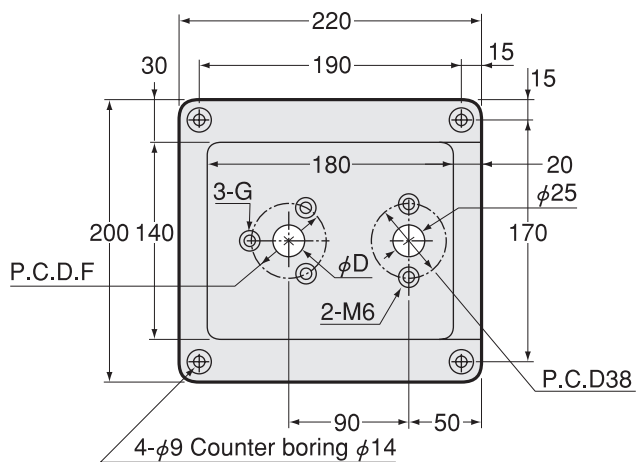

TYPE2

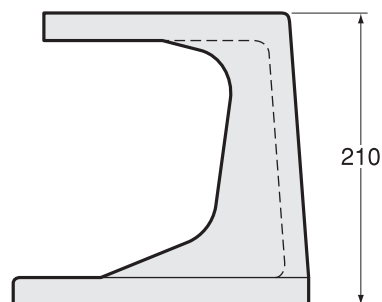
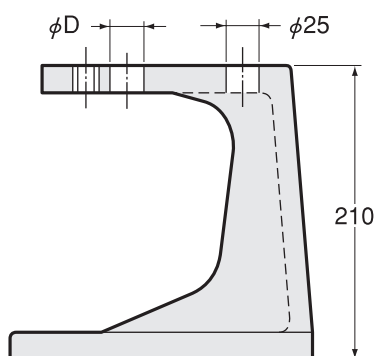
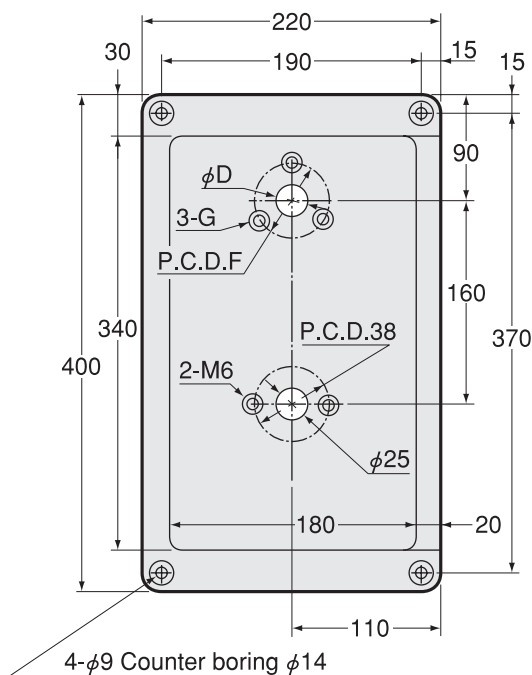

Code	Model	Type	φF	φD <sup>+0.2</sup> <sub>0</sub>	G	Holder support	Gauge stand
0091 07000130	<b>PBN -1-30</b>	1	59	48	M6	PH-NT30	PS-1 ~ PS-5 PS-H4
0091 07000230	<b>PBN -2-30</b>	2	59	48	M6	PH-NT30	PS-1 ~ PS-5 PS-H4
0091 07000135	<b>PBN -1-35</b>	1	59	48	M6	PH-NT35	PS-1 ~ PS-5 PS-H4
0091 07000235	<b>PBN -2-35</b>	2	59	48	M6	PH-NT35	PS-1 ~ PS-5 PS-H4
0091 07000140	<b>PBN -1-40</b>	1	65	54	M6	PH-NT40	PS-1 ~ PS-5 PS-H4
0091 07000240	<b>PBN -2-40</b>	2	65	54	M6	PH-NT40	PS-1 ~ PS-5 PS-H4
0091 07000145	<b>PBN -1-45</b>	1	81	68	M8	PH-NT45	PS-1 ~ PS-5 PS-H4
0091 07000245	<b>PBN -2-45</b>	2	81	68	M8	PH-NT45	PS-1 ~ PS-5 PS-H4
0091 07000150	<b>PBN -1-50</b>	1	92	78	M8	PH-NT50	PS-1 ~ PS-5 PS-H4
0091 07000250	<b>PBN -2-50</b>	2	92	78	M8	PH-NT50	PS-1 ~ PS-5 PS-H4

BT  
CAT  
AHO  
HSK-A/E/F/C  
HSK-T  
UTS  
Specialized Machine

Related Equipment  
Bush & Chamfering Drill

Spanner Head  
Torque Wrench

Shrink Fit System

Digital measuring equipment  
reference position

Tool Presetter

HSK Clamper

"R" Zero Setter

Simple Setter