

- For Boring bar

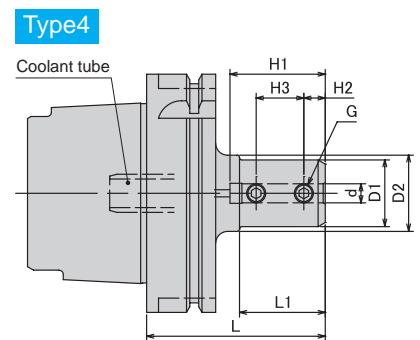
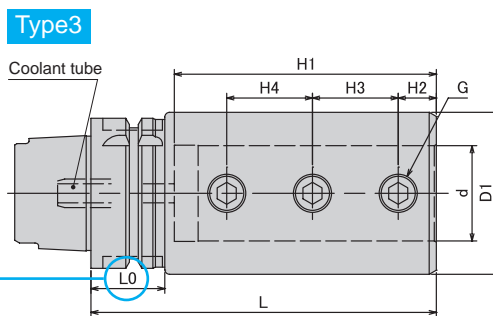
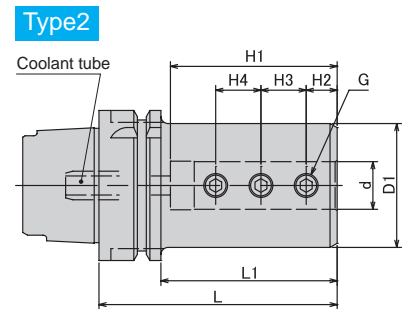
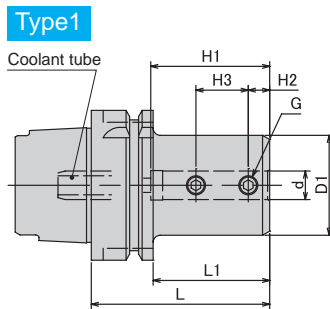

**Caution**  
★ Take caution against A.T.C. arm and tool magazine interference.

- Coolant tube is included.

### Metric Sizes

Unit : Metric

Code	Model	Type	d	L	L1	D1	D2	H1	H2	H3	H4	L0	G	Kg
591004008065	HSK50T -TSB8 - 65	1	8	65	39	28	—	40	9	20	—	—	M8	0.7
591004010070	-TSB10 - 70	1	10	70	44	35	—	45	9	22	—	—	M8	0.8
591004012075	-TSB12 - 75	1	12	75	49	42	—	50	9	22	—	—	M8	1
591004016095	-TSB16 - 95	2	16	95	69	48	—	70	14	18	18	—	M10	1.3
591004020095	-TSB20 - 95	3	20	95	—	52	—	70	14	18	18	31	M10	1.4
591004025110	-TSB25 -110	3	25	110	—	62	—	85	14	26	26	31	M12	2.1
591004032125	-TSB32 -125	3	32	125	—	62	—	100	14	30	30	31	M12	2.1
591005008065	HSK63T -TSB8 - 65	1	8	65	39	28	—	40	9	20	—	—	M8	0.9
591005010070	-TSB10 - 70	1	10	70	44	35	—	45	9	22	—	—	M8	1.1
591005012075	-TSB12 - 75	1	12	75	49	42	—	50	9	22	—	—	M8	1.2
591005016100	-TSB16 -100	2	16	100	74	48	—	70	14	18	18	—	M10	1.7
591005020100	-TSB20 -100	2	20	100	74	52	—	70	14	18	18	—	M10	1.8
591005025115	-TSB25 -115	2	25	115	89	62	—	85	14	26	26	—	M12	2.5
591005032130	-TSB32 -130	2	32	130	104	62	—	100	14	30	30	—	M12	2.6
591005040145	-TSB40 -145	3	40	145	—	68	—	115	16	36	36	32	M16	2.9
591007008075	HSK100T -TSB8 - 75	4	8	75	36	28	32	40	9	20	—	—	M8	2.4
591007010080	-TSB10 - 80	1	10	80	51	35	—	45	9	22	—	—	M8	2.5
591007012085	-TSB12 - 85	1	12	85	56	42	—	50	9	22	—	—	M8	2.7
591007016105	-TSB16 -105	2	16	105	76	48	—	70	14	18	18	—	M10	3.1
591007020105	-TSB20 -105	2	20	105	76	52	—	70	14	18	18	—	M10	3.2
591007025120	-TSB25 -120	2	25	120	91	62	—	85	14	26	26	—	M12	4
591007032135	-TSB32 -135	2	32	135	106	72	—	100	14	30	30	—	M12	4.9
591007040150	-TSB40 -150	2	40	150	121	82	—	115	16	36	36	—	M16	6
591007050180	-TSB50 -180	2	50	180	151	92	—	145	18	38	38	—	M16	7.8

1. Various sizes of boring bar can be clamped by using the coolant/size reduction sleeve, TSS with TSB40.
2. HSK-T type has no manual clamping hole and ID chip recess.

### Ordering Example

**HSK63T - TSB 10 - 70**  
 Shank size                      I.D. (d)                      Projection length (L)

TSB Accessories

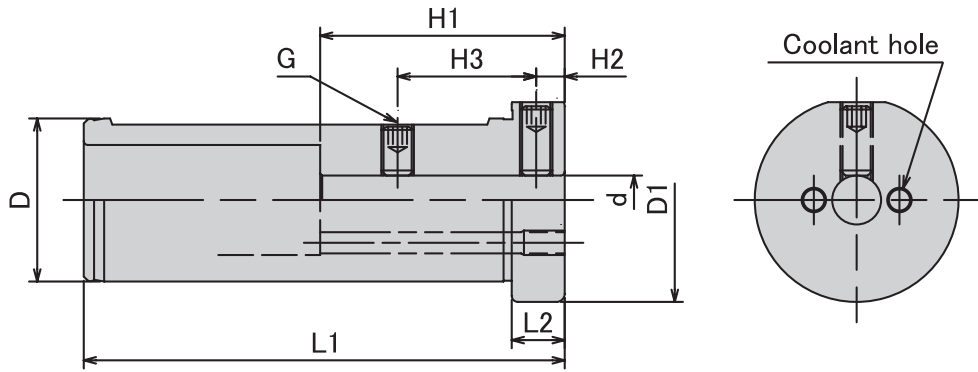

Coolant/Size Reduction Sleeve for TSB40

TSS

Metric Sizes

Unit : Metric

Code	Model	d	L1	L2	D	D1	H1	H2	H3	G	Kg
591400004008	<b>TSS 40 - 8</b>	8	118	13	40	50	50	7	34	M8	1
591400004010	<b>-10</b>	10	118	13	40	50	50	7	34	M8	1
591400004012	<b>-12</b>	12	118	13	40	50	60	7	34	M8	1
591400004016	<b>-16</b>	16	118	13	40	50	70	7	34	M8	0.9

- 1.TSS can be used for TSB40 only.
- 2.For coolant use, plug one of two coolant holes with plug screw.
- 3.One plug screw for coolant hole (M6×10) is included.
- 4.Various sizes of boring bar can be clamped by using the coolant/size reduction sleeve, TSS with TSB40.

Ordering Example

**TSS 40 - 10**  
 I.D. (d)                      Projection length (L)