

- For External / Cut-off

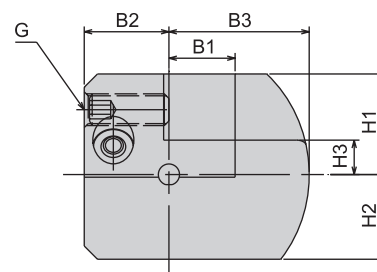
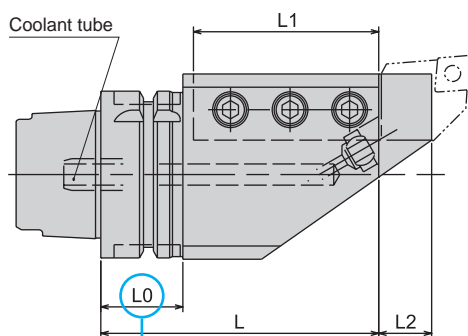

Right-hand drawing shown

Caution
★ Take caution against A.T.C. arm and tool magazine interference.

- Coolant tube is included.

Metric Sizes

Unit : Metric

Code	Model	L	L1	L2	B1	B2	B3	H1	H2	H3	L0	G	Kg
590004040095	HSK50T -SBV2020 R - 95	95	60	15	20	25	43.5	25	25	5	31	M10	2
590004041095	L - 95	95	60	15	20	25	43.5	25	25	5	31	M10	2
590005040095	HSK63T -SBV2020 R - 95	95	60	15	20	32	43.5	33	32	13	32	M10	2.7
590005041095	L - 95	95	60	15	20	32	43.5	33	32	13	32	M10	2.7
590005050105	-SBV2525 R -105	105	70	20	25	32	45	30	30	5	32	M12	2.9
590005051105	L -105	105	70	20	25	32	45	30	30	5	32	M12	2.9
590007050150	HSK100T -SBV2525 R -150	150	110	20	25	37	59	48	43	23	35	M12	8.5
590007051150	L -150	150	110	20	25	37	59	48	43	23	35	M12	8.5
590007060150	-SBV3232 R -150	150	110	20	32	40	68.5	45	43	15	35	M14	9
590007061150	L -150	150	110	20	32	40	68.5	45	43	15	35	M14	9

1. Direction of coolant nozzle can be adjusted. (Coolant may not reach the cutting edge properly depending on the bit shape.)
2. Please shorten a square bit if necessary.
3. HSK-T type has no manual clamping hole and ID chip recess.

Ordering Example

HSK63T - SBV 2020 R - 95
 Shank size □ Left hand - L Projection length (L)
 □ Right hand - R