



Tooling System for Brother's *SPEEDIO*

Compatible models **M200Xd1, M200Xd1-5AX, M300Xd1** (M140X1, M140X2, M200X3, M300X3)



SPEEDIO Turning center + Machining center

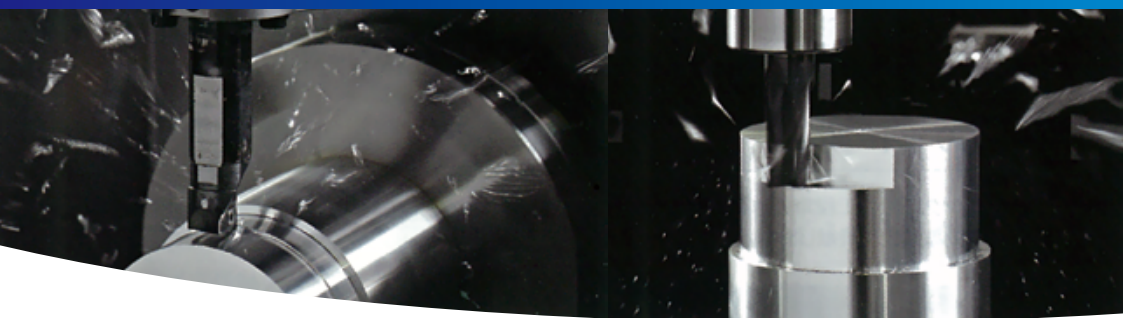

NT TOOL

Turning Tool Series

For External / Facing

SBV·A

Code	Model	L	L1	L2	L3	L4	B1	B2	B3	H1	H2	H3	G	Kg	
2120 12020098	BT30 -SBV2020	RA	-98	98	50	7	30	20	20	41	29	29	9	M10	2.0
2120 12120098		LA													
0702 02932000	BT30 -SBV0750	RA	-98	98	50	7	30	19.05	20	41	29	29	9	M10	2.0
0702 02933000		LA													

1. Direction of the coolant nozzle is adjustable.
2. Please replace the standard coolant nozzle with the replacement copper tube coolant nozzle (included) in case coolant is not reaching the cutting edge.
3. Please shorten the square bit if necessary.
4. The location of the square bit can be changed by re-positioning the plate.

Ordering Example

BT30 - SBV 2020 R A - 98

Shank size Left hand - L Projection length
Right hand - R

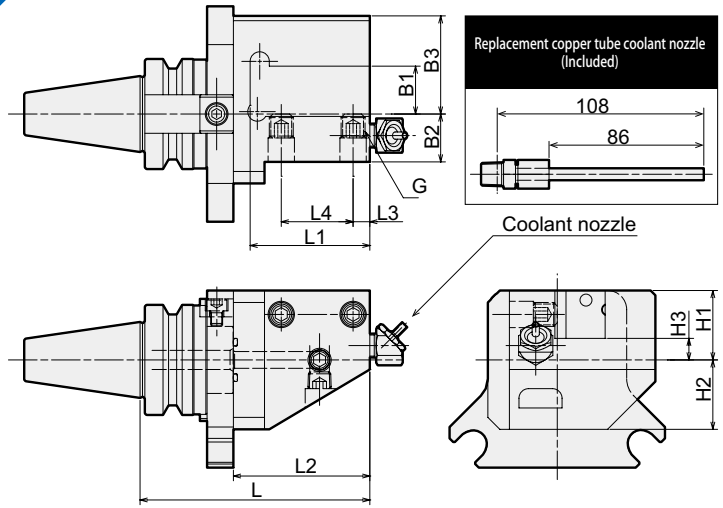

Right hand type shown above.

For Facing

SBH·A

Code	Model	L	L1	L2	B1	B2	B3	H1	H2	H3	H4	G	Kg		
2120 11020081	BT30 -SBH2020	RA	-81	81	20	40	20	41	20	29	29	13	32	M10	1.8
2120 11120081		LA													
0702 02934000	BT30 -SBH0750	RA	-81	81	20	40	19.05	41	20	29	29	13	32	M10	1.8
0702 02935000		LA													

1. Direction of the coolant nozzle is adjustable.
2. Please replace the standard coolant nozzle with the replacement copper tube coolant nozzle (included) in case coolant is not reaching the cutting edge.
3. Please shorten the square bit if necessary.
4. The location of the square bit can be changed by re-positioning the plate.

Ordering Example

BT30 - SBH 2020 R A - 81

Shank size Left hand - L Projection length
Right hand - R

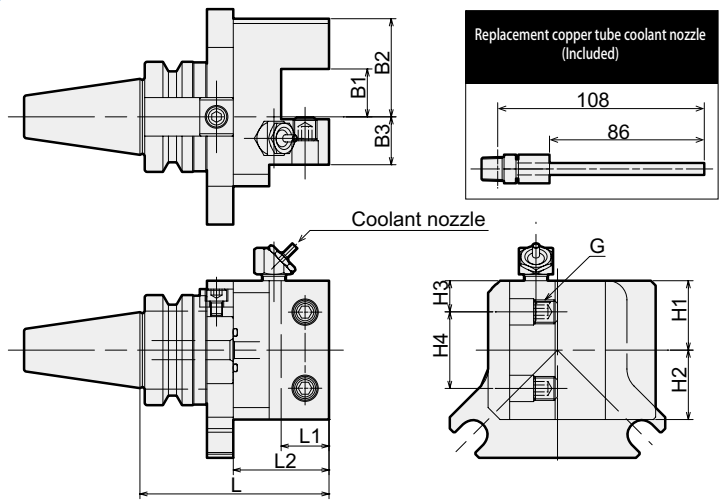

Right hand type shown above.

For Boring bar

TSB

Code	Model	Type	d	D	L	L1	L2	L3	L4	L5	L6	G	Kg
2120 00010038	BT30 -TSB10 - 38	1	10	-	38	40	15	15	-	-	5	M6	0.8
2120 00010068		2	10	20	68	45	12	12	-	30	5	M6	0.9
2120 00012038	BT30 -TSB12 - 38	1	12	-	38	40	15	15	-	-	5	M6	0.8
2120 00012068		2	12	22	68	65	12	12	26	30	5	M6	0.9
2120 00016038	BT30 -TSB16 - 38	1	16	-	38	46	15	15	-	-	5	M6	0.8
2120 00016068		2	16	27.5	68	76	12	12	26	30	5	M6	0.9
2120 00020038	BT30 -TSB20 - 38	1	20	-	38	46	15	15	-	-	5	M6	0.8
0742 04465000		2	19.05	-	38	46	15	15	-	-	5	M6	0.8

Ordering Example

BT30 - TSB 20 - 38

Shank size d Projection length

Retention Stud

- PSB-OA
- PSB-26 (Center-thru compliant)

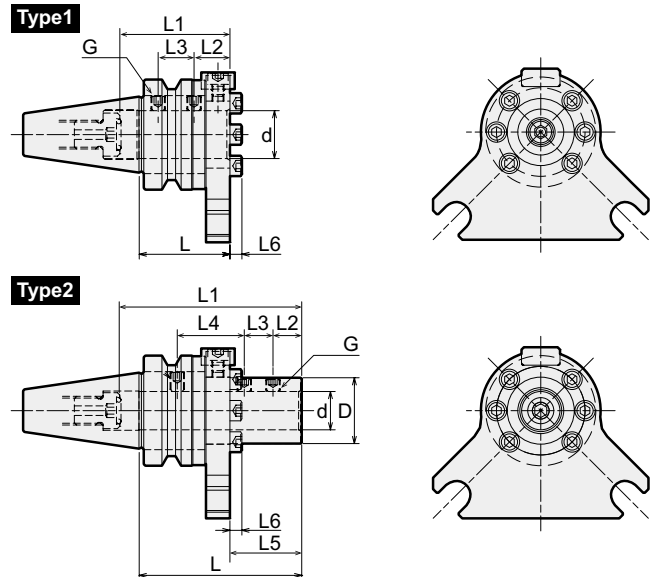

If you are using tools with center-through coolant, please use a center-through coolant capable machine.

Various BT30 shank tool holders are available. Please contact NT TOOL for details.

Power Hydro Chuck

PHC·A

Hydro chuck with collet holder flexibility. Suitable for high precision cutting.

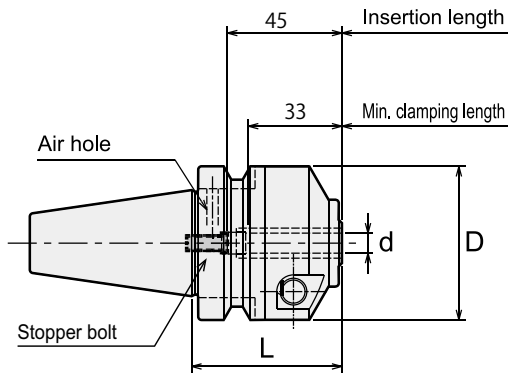

Code	Model	L	d	D	kg
3930 01112045	BT30 - PHC12A - 45	45	12	46	0.6
3932 01290000	BT30 - PHC0750A - 45	45	19.05	46	0.6
6080 00115576	Wrench : L-4T	—			

1. Cutting tool shank must be within tolerances specified below ;
Shank diameter less than 6mm : Within h6 tolerance
Shank diameter 6mm and over : Within h7 tolerance
h6 or 0/-0.01 tolerance is recommended when making a new cutting tool.
2. The PHC12A/PHC0750A has pin holes for collets with stopper pins.
3. Size reducing collet, PHS is available. Please contact NT USA.
4. Hex-head screws (included) are necessary to plug air holes for center through coolant feed.



For more information, please refer to NTTOOL web site.
<https://www.nttoolusa.com/products/pid/22/>

Collet Holder

HDC·A

Suitable for drilling, reaming and finish endmilling.

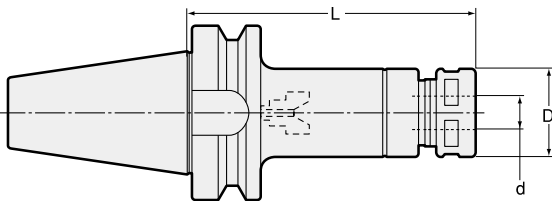

Code	Model	L	d	D	kg
2540 10112045	BT30 - HDC12A - 45	45	2.5~12.0	32	0.5
0803 00000013	Spanner : S-3L	—			
—	Collet : FDC-12-AA	ø3.0 ~ ø12.7			
—	Collet : FDC-120H AA	ø3.0 ~ ø12.0 (Cutter with oil hole)			
—	Collet : FDC-12-C AA	ø3.0 ~ ø12.0 (For collet through coolant)			

1. Standard preset screw is included.



For more information, please refer to NTTOOL web site.
<https://www.nttoolusa.com/products/pid/12/>

Super tite-lock Milling Chuck

CT·SA

Slim design milling chuck. Specially designed slits enable heavy endmilling.

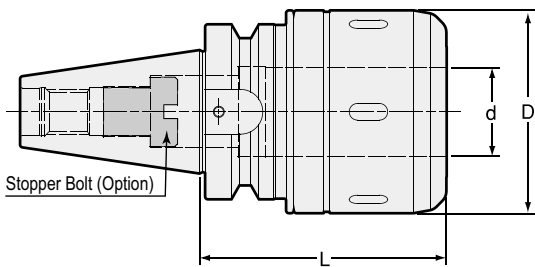

Code	Model	L	d	D	kg
3140 40120075	BT30 - CT20SA - 75	75	20	52	1.0
3140 50124075	BT30 - CT0750SA - 75	75	20	52	1.0
—	Spanner : HS-2-20	—			
—	Collet : MC-20(ø6~16)	—			
—	Collet : MC-0750(ø0250~0625)	—			

1. When ordering, indicate number of spanners required.
"No charge" spanners are limited to number of milling chucks on order.
2. Tolerance of cutting tool shank must be h7.



For more information, please refer to NTTOOL web site.
<https://www.nttoolusa.com/products/pid/228/>

Face Mill Arbor

FMH·A

Coolant flows from the end face of centering location to cutter with oil hole.

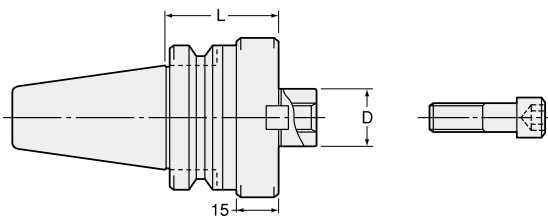

Code	Model	L	D	Clamp bolt
0770 16125060	BT30 - FMH25.4A - 60 - 60	60	25.4	M12

1. Clamp bolt is Included.



For more information, please refer to NTTOOL web site.
<https://www.nttoolusa.com/products/pid/40/>

NT TOOL, the best protection against rust!



Special rust proof coating on entire surface including the tapered shank (BT, CAT, SK only).

Prevent seizure and scoring caused by metal abrasion against the machine spindle.

Special coating protects spindle from abnormal wearing.

Safe with water-soluble coolant.

Some holders are excluded.

- **Protect spindle from damage**
- **Longer cutting tool life**
- **Maintain good accuracy**

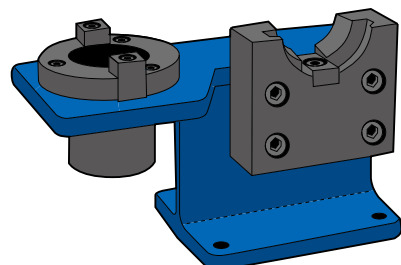

BCL-30
Tightening fixture

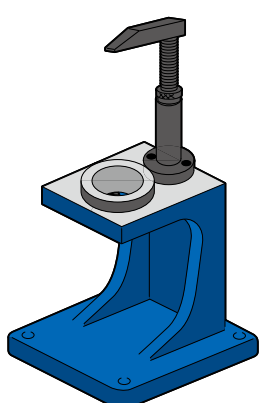

SPN*-NT30
Simple setter

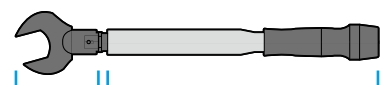

SH



CL



SH and CL series
Torque wrench/head

For more information, please refer to NT TOOL web site.

Your supplier is