

HDC·A-CF

High-Precision Collet Holder (Flange Through Type)

- Flange through coolant type collet holder. DIN69871 Form B compliance.

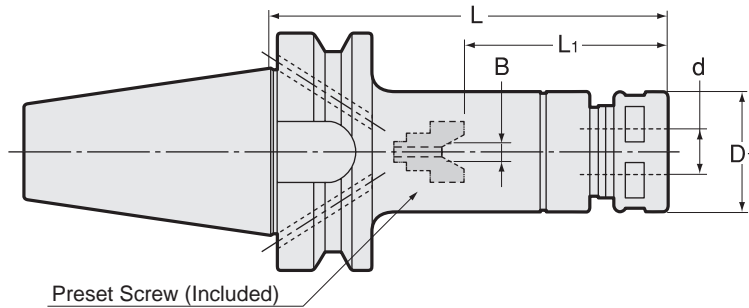

- DIN69871 Form B
- Max. Coolant pressure
6MPa (HDC22A-CF)
7MPa (Other sizes)

Unit : Metric

Code	Model	d	L	B	L1	D1	Nut	kg	Collet	Spanner
2546 10307075	BT40 -HDC07A -75CF	0.5 ~ 7.0	75	0 ~ 4	22 ~ 40	23	HDP-07A	1.1	FDC-07	S-0
2546 10307090	-90CF	0.5 ~ 7.0	90	0 ~ 4	22 ~ 45	23	HDP-07A	1.1		
2546 10307105	-105CF	0.5 ~ 7.0	105	0 ~ 4	22 ~ 45	23	HDP-07A	1.2		
2546 10309090	BT40 -HDC09A -90CF	2.5 ~ 9.0	90	0 ~ 4	27 ~ 56	26	HDP-09	1.2	FDC-09	S-1L
2546 10309105	-105CF	2.5 ~ 9.0	105	0 ~ 4	27 ~ 57	26	HDP-09	1.3		
2546 10309120	-120CF	2.5 ~ 9.0	120	0 ~ 4	27 ~ 57	26	HDP-09	1.3		
2546 10309135	-135CF	2.5 ~ 9.0	135	0 ~ 4	27 ~ 57	26	HDP-09	1.4		
2546 10309165	-165CF	2.5 ~ 9.0	165	0 ~ 4	27 ~ 57	26	HDP-09	1.5		
2546 10312090	BT40 -HDC12A -90CF	2.5 ~ 12.0	90	0 ~ 5	33 ~ 54	32	HDP-12	1.3	FDC-12	S-3L
2546 10312105	-105CF	2.5 ~ 12.0	105	0 ~ 5	33 ~ 69	32	HDP-12	1.4		
2546 10312120	-120CF	2.5 ~ 12.0	120	0 ~ 5	33 ~ 69	32	HDP-12	1.5		
2546 10312135	-135CF	2.5 ~ 12.0	135	0 ~ 5	33 ~ 69	32	HDP-12	1.5		
2546 10312165	-165CF	2.5 ~ 12.0	165	0 ~ 5	33 ~ 69	32	HDP-12	1.7		
2546 10312195	-195CF	2.5 ~ 12.0	195	0 ~ 5	33 ~ 69	32	HDP-12	1.9		
2546 10316090	BT40 -HDC16A -90CF	3.5 ~ 16.0	90	0 ~ 6	38 ~ 56	36	HDP-16	1.3	FDC-16	S-4L
2546 10316105	-105CF	3.5 ~ 16.0	105	0 ~ 6	38 ~ 71	36	HDP-16	1.4		
2546 10316120	-120CF	3.5 ~ 16.0	120	0 ~ 6	38 ~ 82	36	HDP-16	1.5		
2546 10316135	-135CF	3.5 ~ 16.0	135	0 ~ 6	38 ~ 82	36	HDP-16	1.7		
2546 10316165	-165CF	3.5 ~ 16.0	165	0 ~ 6	38 ~ 82	36	HDP-16	1.8		
2546 10316195	-195CF	3.5 ~ 16.0	195	0 ~ 6	38 ~ 82	36	HDP-16	2.0		
2546 10322105	BT40 -HDC22A -105CF	3.5 ~ 22.0	105	0 ~ 8	47 ~ 69	46	HDP-22	1.6	FDC-22	S-5L
2546 10322120	-120CF	3.5 ~ 22.0	120	0 ~ 8	47 ~ 84	46	HDP-22	1.8		
2546 10322135	-135CF	3.5 ~ 22.0	135	0 ~ 8	47 ~ 99	46	HDP-22	1.9		
2546 10322165	-165CF	3.5 ~ 22.0	165	0 ~ 8	47 ~ 103	46	HDP-22	2.3		
2546 10322195	-195CF	3.5 ~ 22.0	195	0 ~ 8	47 ~ 103	46	HDP-22	2.6		
2546 10507090	BT50 -HDC07A -90CF	0.5 ~ 7.0	90	0 ~ 4	22 ~ 45	23	HDP-07A	3.5	FDC-07	S-0
2546 10507105	-105CF	0.5 ~ 7.0	105	0 ~ 4	22 ~ 45	23	HDP-07A	3.6		
2546 10507120	-120CF	0.5 ~ 7.0	120	0 ~ 4	22 ~ 45	23	HDP-07A	3.7		
2546 10507135	-135CF	0.5 ~ 7.0	135	0 ~ 4	22 ~ 45	23	HDP-07A	3.8		
2546 10507165	-165CF	0.5 ~ 7.0	165	0 ~ 4	22 ~ 45	23	HDP-07A	3.9		
2546 10507195	-195CF	0.5 ~ 7.0	195	0 ~ 4	22 ~ 45	23	HDP-07A	4.0		
2546 10509090	BT50 -HDC09A -90CF	2.5 ~ 9.0	90	0 ~ 4	27 ~ 48	26	HDP-09	3.6	FDC-09	S-1L
2546 10509105	-105CF	2.5 ~ 9.0	105	0 ~ 4	27 ~ 57	26	HDP-09	3.7		
2546 10509120	-120CF	2.5 ~ 9.0	120	0 ~ 4	27 ~ 57	26	HDP-09	3.8		
2546 10509135	-135CF	2.5 ~ 9.0	135	0 ~ 4	27 ~ 57	26	HDP-09	3.9		
2546 10509165	-165CF	2.5 ~ 9.0	165	0 ~ 4	27 ~ 57	26	HDP-09	4.0		
2546 10509195	-195CF	2.5 ~ 9.0	195	0 ~ 4	27 ~ 57	26	HDP-09	4.1		
2546 10509225	-225CF	2.5 ~ 9.0	225	0 ~ 4	27 ~ 57	26	HDP-09	4.2		
2546 10509255	-255CF	2.5 ~ 9.0	255	0 ~ 4	27 ~ 57	26	HDP-09	4.3		

Code	Model	d	L	B	L1	D1	Nut	kg	Collet	Spanner
2546 10512090	BT50 -HDC12A -90CF	2.5 ~ 12.0	90	0 ~ 5	33 ~ 47	32	HDP-12	3.7	FDC-12	S-3L
2546 10512105	-105CF	2.5 ~ 12.0	105	0 ~ 5	33 ~ 62	32	HDP-12	3.8		
2546 10512120	-120CF	2.5 ~ 12.0	120	0 ~ 5	33 ~ 69	32	HDP-12	3.9		
2546 10512135	-135CF	2.5 ~ 12.0	135	0 ~ 5	33 ~ 69	32	HDP-12	4.0		
2546 10512165	-165CF	2.5 ~ 12.0	165	0 ~ 5	33 ~ 69	32	HDP-12	4.1		
2546 10512195	-195CF	2.5 ~ 12.0	195	0 ~ 5	33 ~ 69	32	HDP-12	4.2		
2546 10512225	-225CF	2.5 ~ 12.0	225	0 ~ 5	33 ~ 69	32	HDP-12	4.3		
2546 10512255	-255CF	2.5 ~ 12.0	255	0 ~ 5	33 ~ 69	32	HDP-12	4.4		
2546 10516090	BT50 -HDC16A -90CF	3.5 ~ 16.0	90	0 ~ 6	38 ~ 47	36	HDP-16	3.7		
2546 10516105	-105CF	3.5 ~ 16.0	105	0 ~ 6	38 ~ 62	36	HDP-16	3.8		
2546 10516120	-120CF	3.5 ~ 16.0	120	0 ~ 6	38 ~ 77	36	HDP-16	3.9		
2546 10516135	-135CF	3.5 ~ 16.0	135	0 ~ 6	38 ~ 82	36	HDP-16	4.0		
2546 10516165	-165CF	3.5 ~ 16.0	165	0 ~ 6	38 ~ 82	36	HDP-16	4.2		
2546 10516195	-195CF	3.5 ~ 16.0	195	0 ~ 6	38 ~ 82	36	HDP-16	4.4		
2546 10516225	-225CF	3.5 ~ 16.0	225	0 ~ 6	38 ~ 82	36	HDP-16	4.6		
2546 10516255	-255CF	3.5 ~ 16.0	255	0 ~ 6	38 ~ 82	36	HDP-16	4.8		
2546 10522105	BT50 -HDC22A -105CF	3.5 ~ 22.0	105	0 ~ 8	47 ~ 60	46	HDP-22	4.0	FDC-22	S-5L
2546 10522120	-120CF	3.5 ~ 22.0	120	0 ~ 8	47 ~ 75	46	HDP-22	4.2		
2546 10522135	-135CF	3.5 ~ 22.0	135	0 ~ 8	47 ~ 90	46	HDP-22	4.3		
2546 10522150	-150CF	3.5 ~ 22.0	150	0 ~ 8	47 ~ 103	46	HDP-22	4.4		
2546 10522165	-165CF	3.5 ~ 22.0	165	0 ~ 8	47 ~ 103	46	HDP-22	4.6		
2546 10522195	-195CF	3.5 ~ 22.0	195	0 ~ 8	47 ~ 103	46	HDP-22	4.8		
2546 10522225	-225CF	3.5 ~ 22.0	225	0 ~ 8	47 ~ 103	46	HDP-22	5.0		
2546 10522255	-255CF	3.5 ~ 22.0	255	0 ~ 8	47 ~ 103	46	HDP-22	5.2		

1. Collet, spanner, hexagon head preset screw and preset screw for semi-dry processing are sold separately. Standard preset screw is included.
2. Refer to P. 092 for minimum tool insertion length in case of using our coolant collets (OH,C or MS).
3. L1 indicates dimension when using with a preset screw.
4. See P.499 for standard Tightening Torque.

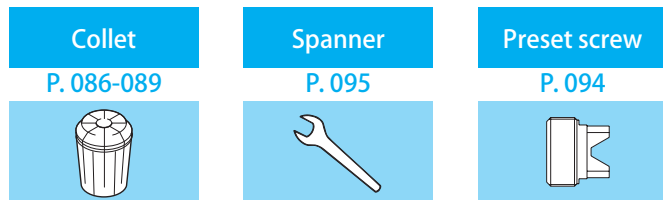

Ordering Example

BT30 - HDC 16 A - 105 CF

Shank size

Max. collet I.D.

Projection
length (L)