

# KTP

## Quick Change Stub Tapper

### Applications

- Spindle Feed : Pitch Feed
- Designed for use on special-purpose machine, transfer machine etc.

### Feature

- Small shank and projection length makes your tapping job very stable.
- Simple spindle designing/machining makes your machine compact.
- Radial float corrects alignment discrepancies between pre-drilled hole and tap.
- Quick change

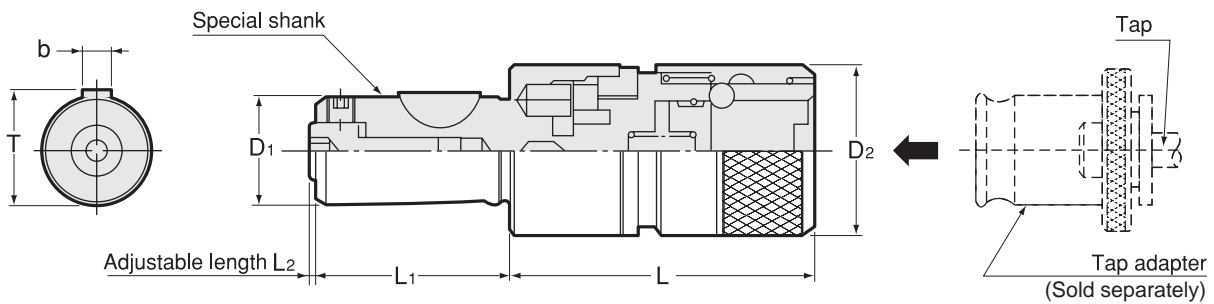

For capable tap sizes, please refer to P. 462-464 chart.

Code	Model	Tap Size	Adapter size	Radial float	D1 <sub>h6</sub>	D2	L	L1 <sub>±0.1</sub>	T	b	L2	kg
0831 00000000	<b>KTP0</b>	M3 ~ M8 (M10) U1/4 ~ U5/16 (U3/8)	0	0.25	16	23	54	31	17.1	5	0 ~ 2	0.2
0831 00000001	<b>KTP1</b>	M3 ~ M12 (M15) U1/4 ~ U7/16 (U9/16) Pipe(PT,PS,PF)1/8 ~ 1/4	1	0.5	20	32	58	37	21.1	5	0 ~ 2	0.4
0831 00000040	<b>KTP40</b>	M6 ~ M18 U1/4 ~ U3/4	40	0.75	28	40	78	49	29.5	6	0 ~ 2	0.8
0831 00000002	<b>KTP2</b>	M8 ~ M22 U3/8 ~ U7/8 Pipe(PT,PS,PF)1/8 ~ 1/2	2	1	28	50	85	49	29.5	6	0 ~ 2	1.2

1. Tap size in brackets are for light tapping only.
2. Tap adapter is sold separately.

### Tap Adapter

P. 458

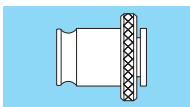

### Ordering Example

**KTP1**  
Adapter size

- BT
- CAT
- AHO
- HSK-A/E/F/C
- HSK-T
- UTS
- Specialized Machine
- Related Equipment
- Bush & Chamfering Drill

Sub Holder

Tapping Chuck

Tap Adapter

Adjustable Adapter

Endmill Chuck

Straight Drill Chuck

Floating Holder

## Special Spindle Dimension

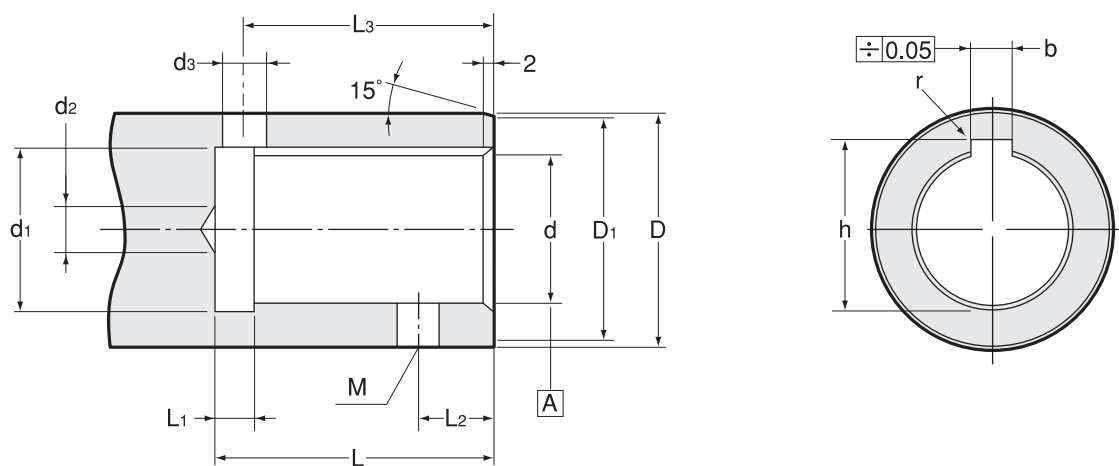

For KTP, KTL, KTLP

Size	d H6	L +0.5 0	d1	d2 (MAX)	D g6	D1	d3	L1	L2	M	L3	b +0.145 +0.07	h +0.1 +0	r
<b>16</b>	16	31	16.6	4	25	24	6	5	10	M6	27	5	17.3	0.2
<b>20</b>	20	37	20.6	6	32	31	6	5	10	M6	33	5	21.3	0.2
<b>28</b>	28	49	28.6	10	40	39	8	5	12	M8	44	6	29.7	0.4

# QUICK CHANGE TAP ADAPTER

## Basic 4 Models

**WE**

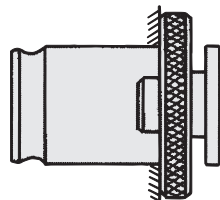

**WE** Quick Change

**WES · B**

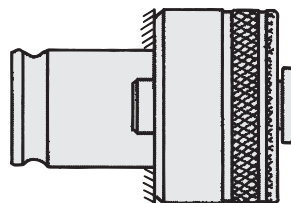

**WE** Quick Change

**S** Safety Torque

**WEN**

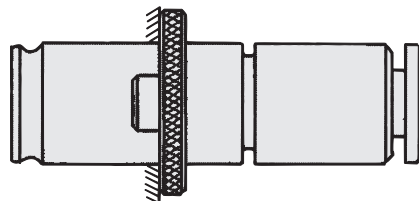

**WE** Quick Change

**N** Length Adjustment

**WESN · B**

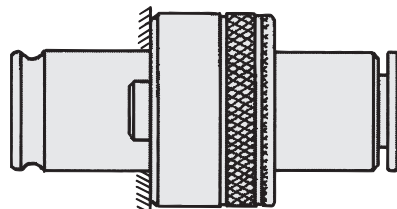

**WE** Quick Change

**S** Safety Torque

**N** Length Adjustment

In addition to the basic 4 models, wide variety of models (extended size, enlarged size, R type for short shank tap etc.) are available.

WE : Quick Change

Tapping chuck and tapping adapter

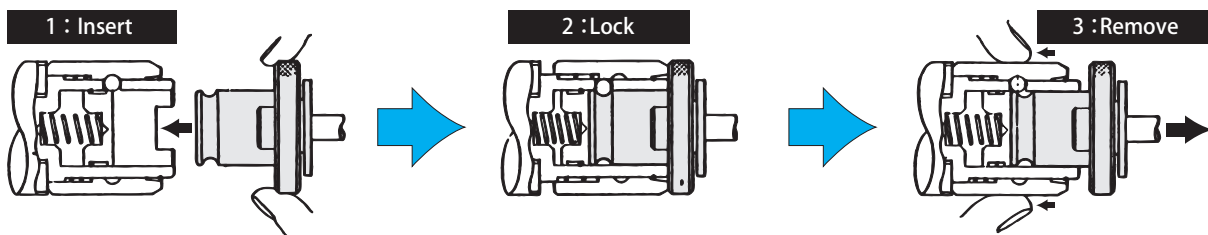

- 1 : Simply insert tap adapter into tapping chuck.
- 2 : Tapping chuck and tap adapter are connected firmly.
- 3 : Push down on operation sleeve of tapping chuck while removing tap adapter.

Tapping adapter and Tap

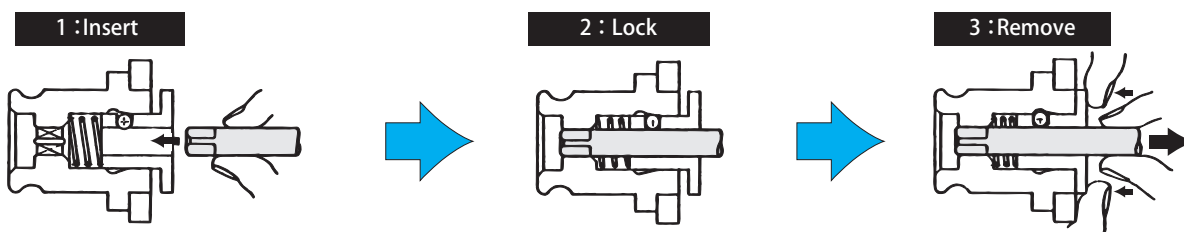

- 1 : Insert tap into bottom of tap adapter, and rotate tap manually to connect them firmly.
- 2 : Tap and adapter are connected firmly.
- 3 : Push down on ball bush while removing tap.

S : Safety torque

Safe torque device activates to prevent breakage tap when torque more than fixed amount is applied to tap. (Use with a tapper equipped with axial compensation mechanism.)

Normal operation (Normal machining)

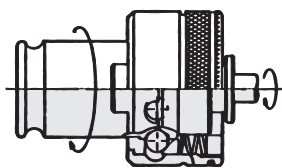

Empty operation (Abnormal machining torque)

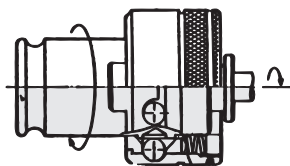

Reverse operation (Torque device doesn't move in the reverse direction)

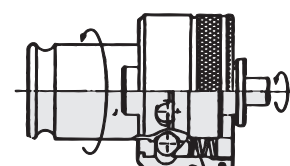

When using left handed tap adapter, please specify.

N : Length adjustment

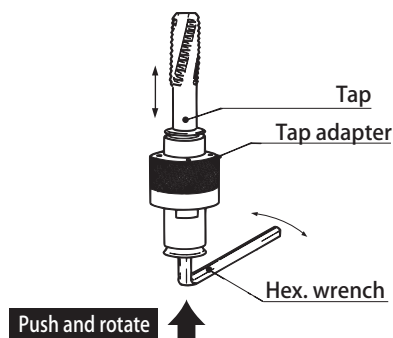

Insert hex. wrench into bottom of tap adapter and turn to adjust tool length.

Tap adapter with tool adjustment mechanism can be recommended for following conditions.

- 1.Tool adjustment with prestting gauge.
- 2.When tap length changes due to re-grinding.
- 3.When you do not want to use N/C machine tool compensation function.

# WE

## Quick Change Tap Adapter

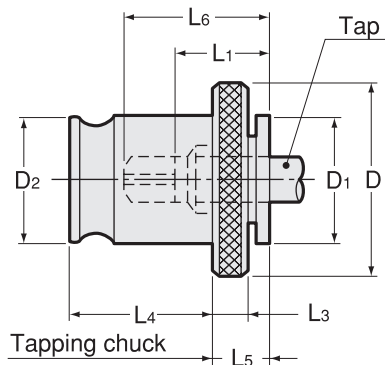

### Applications

- For through hole, blind hole, right-hand thread and left-hand thread.

### Feature

- Quick Change
- ※ In case you are afraid of tap breakage, choose a WES ·B and a tapping chuck with safety torque clutch.

For capable tap sizes, please refer to P.462-464 chart.

Code	Model	Tap Size	Chuck size	D	D1	D2	L1	L3	L4	L5	kg
0210 0000 ※※※	<b>WE0</b>	M3 ~ M8 (M10) U1/4 ~ U5/16 (U3/8)	0	22	12.5	13	15	4	19.5	7	0.03
0210 0001 ※※※	<b>WE1</b>	M3 ~ M12 (M15) U1/4 ~ U7/16 (U9/16) Pipe(PT,PS,PF)1/8 ~ 1/4	1 32	30	19	19	17	4	21.5	7	0.06
0210 0004 ※※※	<b>WE40</b>	M6 ~ M18 U1/4 ~ U3/4	40	40	25	26	30	5	32	13	0.12
0210 0002 ※※※	<b>WE2</b>	M8 ~ M22 U3/8 ~ U7/8	2	48	30	31	30	5	35	11	0.25
0210 0003 ※※※	<b>WE3</b>	M26 ~ M38 U1 ~ U1 3/8	3	70	47	48	44	6	55.5	14	0.8
—	<b>WE4</b>	7/8 ~ 1-3/4 M22 ~ M48	4	90	60	60	71	13	63	42	

1. Tap sizes in brackets are for light tapping only.
2. Calculate tap projection length from L1 dimension.
3. L1 and L6 dimensions fluctuate with tap sizes. Always take into account ± 1.5mm allowance.
4. Refer to P.462 for tap shank dia. and square dimension.

### Ordering Example

**WE1 M8J**  
Adapter size Tap size

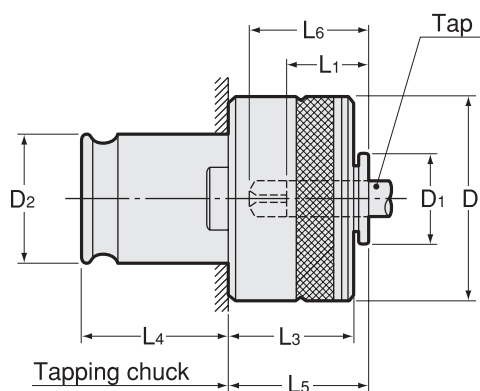

### Applications

- For right-hand thread only. Through hole and blind hole.

### Feature

- Quick Change
- Safety torque clutch actuates to prevent tap breakage when an excessive torque is applied to tap. In this case, a tapping chuck with compression device should be used together.

 For capable tap sizes, please refer to P.462-464 chart.

Code	Model	Tap Size	Chuck size	D	D1	D2	L1	L3	L4	L5	kg
0210 06000 ※※※	<b>WES0B</b>	M3 ~ M8 (M10) U1/4 ~ U5/16 (U3/8)	0	23	12.5	13	15	20	19.5	21	0.06
0210 06001 ※※※	<b>WES1B</b>	M3 ~ M12 (M15) U1/4 ~ U7/16 (U9/16) Pipe(PT,PS,PF)1/8 ~ 1/4	1 32	32	19	19	17	25	21.5	25	0.15
0210 06040 ※※※	<b>WES40B</b>	M6 ~ M18 U1/4 ~ U3/4	40	40	25	26	30	27	32	30	0.3
0210 06002 ※※※	<b>WES2B</b>	M8 ~ M22 U3/8 ~ U7/8	2	50	30	31	30	31	35	33	0.6
0210 06003 ※※※	<b>WES3B</b>	M26 ~ M38 U1 ~ U1 3/8	3	72	47	48	44	41	55.5	45	1.5
—	<b>WES4B</b>	7/8 ~ 1-3/4 M22 ~ M48	4	95	60	60	71	61	63	68	

1. Tap sizes in brackets are for light tapping only.
2. Calculate tap projection length from L1 dimension.
3. Tapping chuck with compression device should be used together.
4. Specify PT, PS or PF when using a pipe tap, as each of them has various safety torque value.
5. L1 and L6 dimensions fluctuate with tap sizes. Always take into account  $\pm 1.5$ mm allowance.
6. Refer to P.462 for tap shank dia. and square dimension.

### Ordering Example

**WES1B M8J**

Adapter size Tap size

# WEN

## Quick Change Tap Adapter

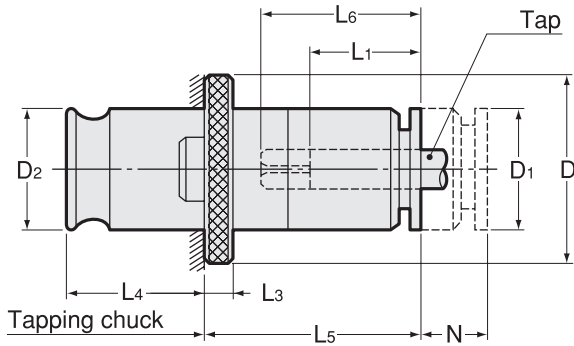

### Applications

- For through hole, blind hole, right-hand thread and left-hand thread.

### Feature

- Quick Change
- Length adjustment facilitates your depth control of re-ground tap.

**!** For capable tap sizes, please refer to P.462-464 chart.

Code	Type	Tap Size	Chuck Size	N	D	D1	D2	L1	L3	L4	L5
—	WEN0	M3 ~ M8(M10) U1/4 ~ U5/16 (U3/8)	0	8	22	13	13	15	4	19.5	29
—	WEN1	#0-12, 1/4 - 1/2 M3-M12	1	10	30	19	19	17	4	21.5	34
—	WEN2	5/16 - 7/8 M8-M20	2	15	48	30	31	30	5	35	60
—	WEN3	13/16 - 1-3/8 M14-M33	3	25	70	48	48	44	6	55.5	83

1. Tap sizes in brackets are for light tapping only.
2. Calculate tap projection length from L1 dimension.
3. L1 and L6 dimensions fluctuate with tap sizes. Always take into account ± 1.5mm allowance.
4. Refer to P.462 for tap shank dia. and square dimension.

### Ordering Example

**WEN1 M11**  
Adapter size Tap size

BT  
 CAT  
 AHO  
 HSK-A/E/F/C  
 HSK-T  
 UTS  
 Specialized Machine  
 Related Equipment  
 Bush & Chamfering Drill  
 Sub Holder  
 Tapping Chuck  
 Tap Adapter  
 Adjustable Adapter  
 Endmill Chuck  
 Straight Drill Chuck  
 Floating Holder

# WESN · B

## Quick Change Tap Adapter

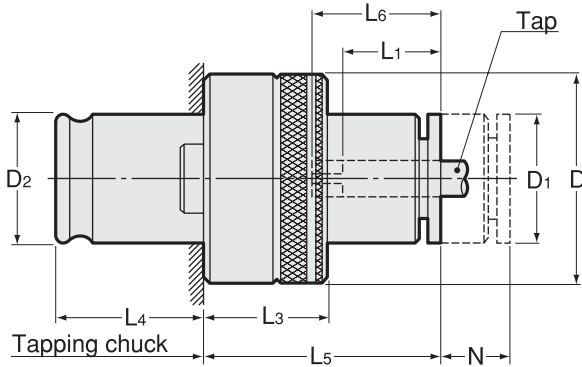

### Applications

- For right-hand thread only. Through hole and blind hole.

### Feature

- Quick Change
- Safety torque clutch actuates to prevent tap breakage when an excessive torque is applied to tap. In this case, a tapping chuck with compression device should be used together.
- Length Adjustment facilitates your depth control of re-ground tap.

 For capable tap sizes, please refer to P.462-464 chart.

Code	Model	Tap Size	Chuck size	N Adjustable length	D	D1	D2	L1	L3	L4	L5	kg
0210 06100 ※※※	WESN0B	M3 ~ M8 (M10) U1/4 ~ U5/16 (U3/8)	0	8	23	13	13	15	20	19.5	28	0.1
0210 06101 ※※※	WESN1B	M3 ~ M12 (M15) U1/4 ~ U7/16 (U9/16) Pipe(PT,PS,PF)1/8 ~ 1/4	1 32	10	32	19	19	17	25	21.5	33	0.2
0210 06140 ※※※	WESN40B	M6 ~ M18 U1/4 ~ U3/4	40	15	40	25	26	30	27	32	53	0.4
0210 06102 ※※※	WESN2B	M8 ~ M22 U3/8 ~ U7/8	2	15	50	30	31	30	31	35	59	0.7
0210 06103 ※※※	WESN3B	M26 ~ M38 U1 ~ U1 3/8	3	25	72	48	48	44	41	55.5	82.5	2.1

1. Tap sizes in brackets are for light tapping only.
2. Calculate tap projection length from L1 dimension.
3. Tapping chuck with compression device should be used together.
4. Specify PT, PS or PF when using a pipe tap, as each of them has various safety torque value.
5. L1 and L6 dimensions fluctuate with tap sizes. Always take into account  $\pm 1.5\text{mm}$  allowance.
6. Refer to P.462 for tap shank dia. and square dimension.

### Ordering Example

**WESN2B M12J**

Adapter size Tap size



## Tapping Capacity

Dimension L6

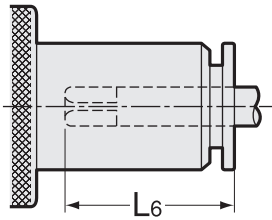

Symbol

⊙ : For JIS (old) Tap

● : For Coarse Thread Tap

※ : For light machining on aluminum alloy and the like

**!** For capable tap sizes, please refer to P.462-464 chart.

### WESN · B、WES · B、WE

Tap Dimension					WESN · B WES · B WE 0		WESN · B WES · B WE 1		WESN · B WES · B WE 40		WESN · B WES · B WE 2		WESN · B WES · B WE 3	
Metric Thread	Unified Thread	Whit-worth Thread	Shank Dia. $\phi$	Square $\square$		L6		L6		L6		L6		L6
M3	NO5,NO6		4	3.2	⊙	22	⊙	23						
M4 M4.5	NO8		5	4	⊙	22.5	⊙	24.5						
M5 M5.5	NO10,NO12		5.5	4.5	⊙	22.5	⊙	24.5						
M6	U1/4	W1/4	6	4.5	⊙	22	⊙	24.5	⊙	36.5				
	U5/16	W5/16	6.1	5	⊙	23	⊙	25	⊙	37.5				
M8 M7			6.2	5	⊙	23	⊙	25.5	⊙	37	⊙	37		
M10 M9	U3/8	W3/8	7	5.5	※	23.5	⊙	25.5	⊙	37	⊙	37		
	M11	U7/16	8	6			⊙	26.5	●	38.5	●	38.5		
M12			8.5	6.5			⊙	26.5	●	38	●	38		
	U1/2	W1/2	9	7			⊙	27	⊙	38.5	⊙	38.5		
M14 M15	U9/16	W9/16	10.5	8			※	28	●	40	●	40		
	U5/8	W5/8	12	9					⊙	41.5	⊙	41.5		
M16			12.5	10					●	42	●	42		
	M17		13	10					⊙	42	⊙	42		
M18	U3/4	W3/4	14	11					⊙	43.5	⊙	43.5		
M20			15	12							⊙	44		
M22	U7/8	W7/8	17	13							⊙	45		
M27 M26	U1	W1	20	15									●	62
	M28		21	17									●	63.5
	U1 1/8	W1 1/8	22	17									●	62.5
M30			23	17									●	62
	M32	U1 1/4	24	19									●	66
M33			25	19									●	66
M35 M34	U1 3/8	W1 3/8	26	21									●	68
M36 M38			28	21									●	67
Pipe Tap Dimension														
PT	PS	PF	$\phi$	$\square$										
1/8	1/8	1/8	8	6			⊙	26.5						
1/4	1/4	1/4	11	9			⊙	29						

## Tapping Capacity

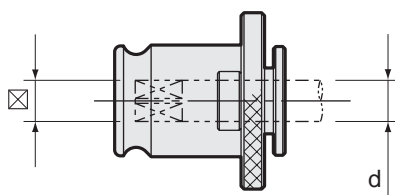

### ANSI

Unit : Inch

Type	Chuck size	Tap size	φ d Tap Shank	☒ Drive Square
WE0 WES0B WEN0 WESN0B	0	#0-6	0.141	0.110
		#8	0.168	0.131
		#10	0.194	0.152
		#12	0.220	0.165
		1/4	0.255	0.191
WE1 WES1B WEN1 WESN1B	1	5/16	0.318	0.238
		#0-6	0.141	0.110
		#8	0.168	0.131
		#10	0.194	0.152
		#12	0.220	0.165
		1/4	0.255	0.191
		5/16	0.318	0.238
		3/8	0.381	0.286
		7/16	0.323	0.242
		1/2	0.367	0.275
WE2 WES2B WEN2 WESN2B	2	1/8SPT	0.313	0.234
		1/8LPT	0.437	0.328
		5/16	0.318	0.238
		3/8	0.381	0.286
		7/16	0.323	0.242
		1/2	0.367	0.275
		9/16	0.429	0.322
		5/8	0.480	0.360
		11/16	0.542	0.406
		3/4	0.590	0.442
WE3 WES3B WEN3 WESN3B	3	13/16	0.652	0.489
		7/8	0.697	0.523
		15/16	0.760	0.570
		1	0.800	0.600
		1-1/8	0.896	0.672
		1-1/4	1.021	0.766
		1-3/8	1.108	0.831
WE4 WES4B	4	1/2PT	0.687	0.515
		3/4PT	0.906	0.679
		1PT	1.125	0.843
		7/8	0.697	0.523
		15/16	0.760	0.570
		1	0.800	0.600
		1-1/8	0.896	0.672
1-1/4	1.021	0.766		
1-3/8	1.108	0.831		
1-1/2	1.233	0.925		
1-3/4	1.430	1.072		

### ISO

Unit : Metric

Type	Chuck size	Tap size	φ d Tap Shank	☒ Drive Square
WE0 WES0B WEN0 WESN0B	0	Please contact NT USA for details.		
WE1 WES1B WEN1 WESN1B	1	M3-1	2.24	1.8
		M3.5, M2	2.5	2.0
		M2.5, M2.2	2.8	2.24
		M4-1, M3-2	3.15	2.5
		M4.5, M3.5	3.55	2.8
		M5-1, M4-2	4.0	3.15
		M6-1	4.5	3.55
		M5-2	5.0	4.0
		M5-3	5.6	4.5
		M8-1, M6-2	6.3	5.0
		M7	7.1	5.6
		M11, M10-1, M8-2	8.0	6.3
		M12, M9	9.0	7.1
		M10-2	10.0	8.0
WE2 WES2B WEN2 WESN2B	2	M14	11.2	9.0
		M5-1, M4-2	4.0	3.15
		M6-1	4.5	3.55
		M5-2	5.0	4.0
		M5-3	5.6	4.5
		M8-1, M6-2	6.3	5.0
		M7	7.1	5.6
		M11, M10-1, M8-2	8.0	6.3
		M12, M9	9.0	7.1
		M10-2	10.0	8.0
		M14	11.2	9.0
		M16	12.5	10.0
		M20, M18	14.0	11.2
		M22	16.0	12.5
WE3 WES3B WEN3 WESN3B	3	M12, M9	9.0	7.1
		M10-2	10.0	8.0
		M14	11.2	9.0
		M16	12.5	10.0
		M20, M18	14.0	11.2
		M22	16.0	12.5
		M24	18.0	14.0
		M30, M27	20.0	16.0
		M33-1	22.4	18.0
		M36, M33-2	25.0	20.0
WE4 WES4B	4	M42, M39	28.0	22.4
		M22	16.0	12.5
		M24	18.0	14.0
		M30, M27	20.0	16.0
		M33-1	22.4	18.0
		M36, M33-2	25.0	20.0

## Tapping Capacity

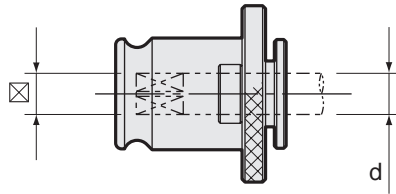

### DIN

Unit : Metric

Type	Chuck size	Tap size	φ d Tap Shank	Drive Square
WE0 WES0B WENO WESN0B	0	M3, M5	3.5	2.7
		M4, M6	4.5	3.4
		M5, M6, M8	6.0	4.9
		M10	7.0	5.5
		M8, M10	8.0	6.2
WE1 WES1B WEN1 WESN1B	1	M3, M5	3.5	2.7
		M3.5	4.0	3.0
		M4, M6	4.5	3.4
		M5, M6, M8	6.0	4.9
		M10	7.0	5.5
		M8, M10	8.0	6.2
		M12	9.0	7.0
WE2 WES2B WEN2 WESN2B	2	M10	10.0	8.0
		M14	11.0	9.0
		M16	12.0	9.0
		M18	14.0	11.0
		M20	16.0	12.0
		M22, M24	18.0	14.5
		M12	9.0	7.0
		M10	10.0	8.0
		M14	11.0	9.0
		M16	12.0	9.0
		M18	14.0	11.0
WE3 WES3B WEN3 WESN3B	3	M20	16.0	12.0
		M22, M24	18.0	14.5
		M27, M30	20.0	16.0
		M33, M36	22.0	18.0
		M36	25.0	20.0
		M22, M24	18.0	14.5
WE4 WES4B	4	M27, M30	20.0	16.0
		M30	22.0	18.0
		M33, M36	25.0	20.0
		M36	28.0	22.0
		M39, M42	32.0	24.0
		M45, M48	36.0	29.0

### JIS

Unit : Metric

Type	Chuck size	Tap size	φ d Tap Shank	Drive Square
WE0 WES0B WENO WESN0B	0	M3	4.0	3.2
		M4, M4.5	5.0	4.0
		M5, M5.5	5.5	4.5
		M6	6.0	4.5
		M7, M8	6.2	5.0
		M9, M10	7.0	5.5
WE1 WES1B WEN1 WESN1B	1	M11	8.0	6.0
		M3	4.0	3.2
		M4, M4.5	5.0	4.0
		M5, M5.5	5.5	4.5
		M6	6.0	4.5
		M7, M8	6.2	5.0
		M9, M10	7.0	5.5
		M11	8.0	6.0
		M12	8.5	6.5
		M13	9.5	7.0
WE2 WES2B WEN2 WESN2B	2	M14, M15	10.5	8.0
		M6	6.0	4.5
		M7, M8	6.2	5.0
		M9, M10	7.0	5.5
		M11	8.0	6.0
		M12	8.5	6.5
		M13	9.5	7.0
		M14, M15	10.5	8.0
		M16	12.5	10.0
		M17	13.0	10.0
		M18	14.0	11.0
		M20	15.0	12.0
		M22	17.0	13.0
WE3 WES3B WEN3 WESN3B	3	M14, M15	10.5	8.0
		M16	12.5	10.0
		M17	13.0	10.0
		M18	14.0	11.0
		M20	15.0	12.0
		M22	17.0	13.0
		M24, M25	19.0	15.0
		M26, M27	20.0	15.0
		M28	21.0	17.0
		M30	23.0	17.0
		M32	24.0	19.0
WE4 WES4B	4	M33	25.0	19.0
		M34, M35	26.0	21.0
		M36, M38	28.0	21.0
		M22	17.0	13.0
		M24, M25	19.0	15.0
		M26, M27	20.0	15.0
		M28	21.0	17.0
		M30	23.0	17.0
		M32	24.0	19.0
		M33	25.0	19.0
		M34, M35	26.0	21.0
		M36, M38	28.0	21.0
		M39, M40	30.0	23.0
		M42	32.0	26.0
M45	35.0	26.0		
M48	38.0	29.0		

## Torque Setting

Torque Wrench (for right thread)

## G type

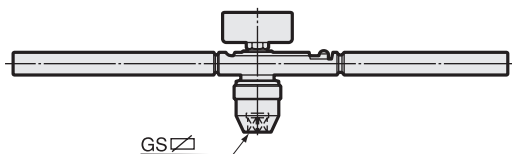

Oil pressure torque wrench with N-m, divisions.

Code	Model	Adapter size	(N-m)	GS ☑
0150 09000000	<b>G0</b>	0	15	13
0150 09000001	<b>G1</b>	0.1	30	13
0150 09000002	<b>G2</b>	2.40	120	13
0150 09000003	<b>G3</b>	3	300	13
0150 09000004	<b>GE4-RD4</b>	4	1,000	25

Setting Shank

## GS type

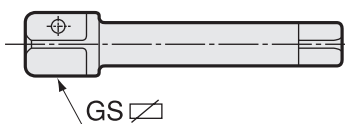

Code	Model	GS ☑	Tapsize
0210 091100 ※※	<b>GS13-M ※※</b>	13	M3 ~ M38
0210 091110 ※※	<b>GS25-M ※※</b>	25	M22 ~ M48

1. Tap size will be inserted in " ※※ ".

2. Square head of setting shank fit into square part of torque wrench.

Setting Socket

## GW type

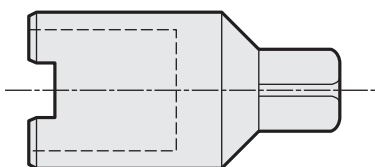

Code	Model	Adapter size
0210 09200000	<b>GW0</b>	0
0210 09200001	<b>GW1</b>	1
0210 09200040	<b>GW40</b>	40
0210 09200002	<b>GW2</b>	2
0210 09200003	<b>GW3</b>	3
0210 09200004	<b>GW4</b>	4

Fix square part of setting socket on vise, and then insert tap adapter into it for torque setting.

Adjustable Pin Wrench

## GWA type

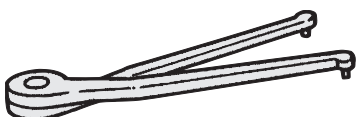

Code	Model	Pin diameter	Adapter size
0150 09300000	<b>GWA0</b>	2	0
0150 09300001	<b>GWA1</b>	2.5	1
0150 09300040	<b>GWA40</b>	3	2、3、40
0150 09300004	<b>GWA4</b>	6	4

Rotate sled ring of tap adapter by pin wrench for torque adjustment.

## Torque setting

Tap adapter type WES · B

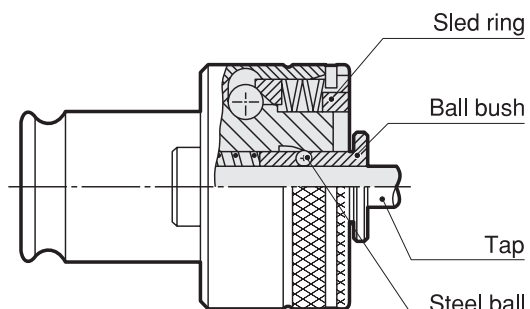

Tap adapter type WESN · B

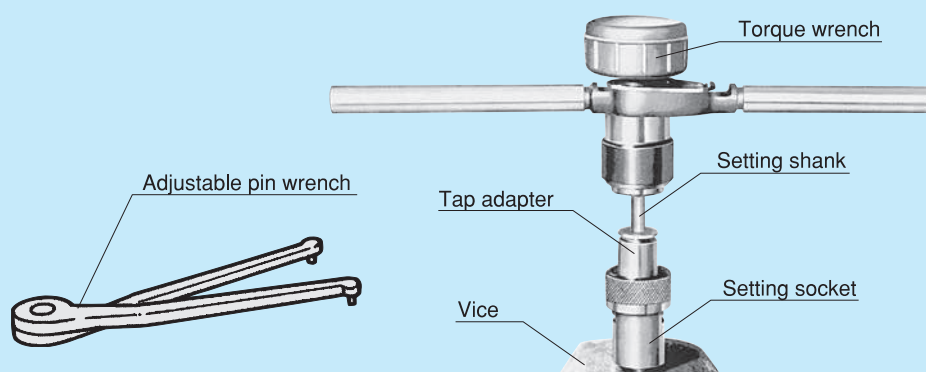
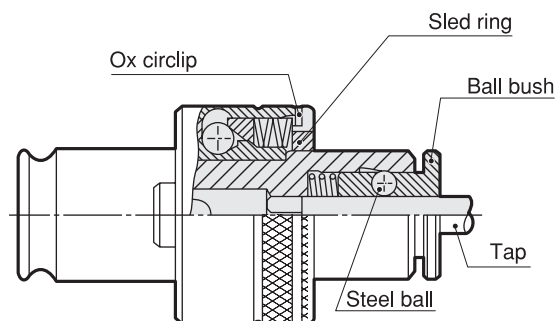

## Torque setting by special tool

- 1) Fix square part of setting socket by using vise.
- 2) Insert tap adapter into the setting socket.
- 3) Insert the setting shank into the tap adapter.
- 4) Insert square part of torque wrench into head part of setting shank.
- 5) Check current torque.
- 6) When changing torque, remove horn part of ox circlip.
- 7) Insert adjustable pin wrench into pin hole of sled ring.
- 8) Rotate sled ring clockwise when increase torque or counterclockwise when decrease torque.
- 9) Check torque again after setting torque.
- 10) After setting the torque, return horn part of ox circlip to original position to fix sled ring.

## Torque setting without special tool

- 1) Remove horn part of ox circlip.
- 2) Insert adjustable pin wrench into pin hole of sled ring.
- 3) Rotate sled ring clockwise when increase torque or counterclockwise when decrease torque. Sled ring rotation must be 45 ~ 90°
- 4) After setting the torque, return horn part of ox circlip to original position to fix sled ring.

Guidelines for Torque Value

Metric Tap		Inch Tap		PT Tap		PS and PF Taps	
Tap Size	Torque (N-m)	Tap Size	Torque (N-m)	Tap Size	Torque (N-m)	Tap Size	Torque (N-m)
M3	1.0	1/8"	2.0	1/8"	26.0	1/8"	8.0
M4	2.3	1/4"	8.0	1/4"	35.0	1/4"	26.0
M5	3.7	5/16"	14.0	3/8"	47.0	3/8"	32.0
M6	6.0	3/8"	22.0	1/2"	100.0	1/2"	65.0
M7	7.5	7/16"	32.0	3/4"	120.0	3/4"	90.0
M8	12.0	1/2"	45.0	1"	240.0	1"	160.0
M9	14.0	9/16"	52.0	1 1/4"	270.0	1 1/4"	200.0
M10	22.0	5/8"	65.0	1 3/8"	300.0	1 3/8"	220.0
M11	26.0			1 1/2"	310.0	1 1/2"	240.0
M12	32.0	3/4"	90.0				
M14	47.0						
M16	52.0	7/8"	120.0				
M18	82.0						
M20	90.0	1"	160.0				
M22	100.0	1 1/8"	220.0				
M24	135.0	1 1/4"	250.0				
M27	160.0	1 3/8"	325.0				
M30	230.0	1 1/2"	360.0				
M33	250.0	1 5/8"	580.0				
M36	310.0	1 3/4"	630.0				
M39	325.0	1 7/8"	750.0				
M40 (細)	210.0	2"	800.0				
M42	420.0						
M45	480.0						
M48	630.0						
M50 (細)	260.0						

- BT
- CAT
- AHO
- HSK-A/E/F/C
- HSK-T
- UTS
- Specialized Machine**
- Related Equipment
- Bush & Chamfering Drill
- Sub Holder
- Tapping Chuck
- Tap Adapter
- Adjustable Adapter
- Endmill Chuck
- Straight Drill Chuck
- Floating Holder