

FDC-C

High-Precision Collet (For Collet Through)

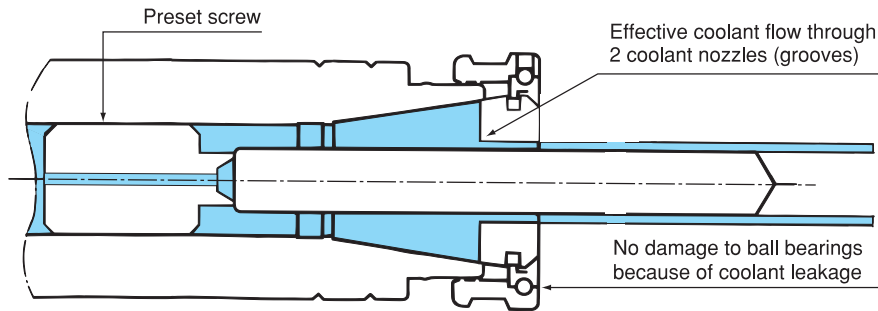

	Tool shank dia.	Model			
		FDC-07-C φ 3 ~ φ 7 (mm) φ 0.118 ~ φ 0.276 (inch)	FDC-09-C φ 3 ~ φ 9 (mm) φ 0.118 ~ φ 0.354 (inch)	FDC-12-C φ 3 ~ φ 12 (mm) φ 0.118 ~ φ 0.472 (inch)	FDC-16-C φ 6 ~ φ 16 (mm) φ 0.236 ~ φ 0.630 (inch)
Milling Chuck					
Collet Holder	φ 3.0 (mm) φ 0.118 (inch)	FDC-03007-C	FDC-03009-C	FDC-03012-C	
"R" Zero Holder		In 0.1mm increments	In 0.1mm increments	In 0.1mm increments	
Hydraulic Chuck		FDC-07007-C	FDC-09009-C		
Shrink Fit			FDC-12012-C		
Tapping Chuck				FDC-16016-C	
Arbors					
Function Holder					
Turning Tool					
Retention Stud					
Tool Shank Dimensions	φ 22.0 (mm) φ 0.866 (inch)				FDC-22022-C

CAA Coolant collets collapse by 0.1mm.

Accuracy (4 × d)	AA (5μm)
	A (10μm)

Ordering Example

FDC - 060 12 - C AA
 Max. 12 Series Accuracy
 chucking dia.

Minimum tool insertion length when coolant collet and tool with tang are used.

HDC-A, GDC-A, ERC, ERC-T, HDZ, GDZ, ERZ

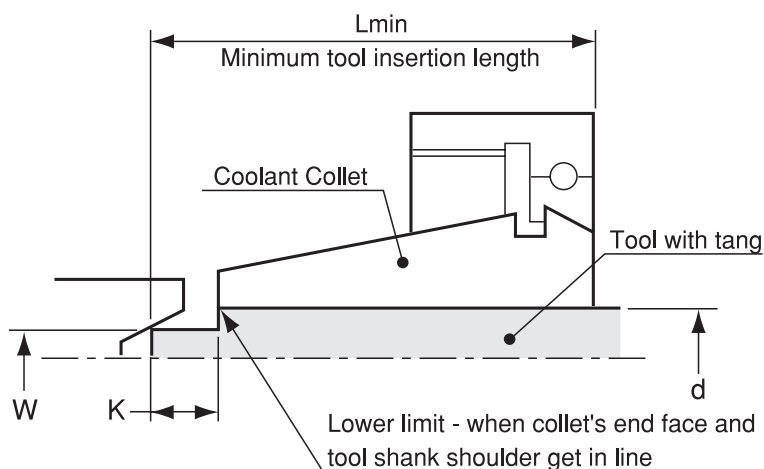

Unit : Metric

Collet size (OH,C,MS)	Chucking diameter	Geometry of cutting tool													
		Tool shank diameter		ø3.1~5.0		ø5.1~6.0		ø6.1~9.0		ø9.1~12.0		ø12.1~16.0		ø16.1~22.0	
		Tang width		2.4		3		4		5		6		8	
Tang length		5	3	6	3	8	5	8	5	10	5	12	5		
ER8	ø1.8~5.0	L min value when using tool with tang		20.5	19	-	-	-	-	-	-	-	-	-	
ER11	ø3.0~7.0	L min value when using tool with tang		23	22	24	22	26	23	-	-	-	-	-	
FDC07	ø3.0~7.0	L min value when using tool with tang		23	22	24	22	26	23	-	-	-	-	-	
FDC09	ø3.0~9.0	L min value when using tool with tang		28	27	29	27	31	28	-	-	-	-	-	
FDC12	ø3.0~12.0	L min value when using tool with tang		33	33	33.5	33	35.5	33	35.5	33	-	-	-	
FDC16	ø6.0~16.0	L min value when using tool with tang		-	-	38.5	38	40.5	38	40.5	38	42.5	38	-	
FDC22	ø6.0~22.0	L min value when using tool with tang		-	-	47	47	47.5	47	47.5	47	49.5	47	51.5	

1. Chamfer at tool tang is NOT taken into account at all.
2. Coolant leakage will happen if minimum insertion length is not kept.
3. Minimum insertion length will vary according to tang length(K).

BT
CAT
AHO
HSK-A/E/F/C
HSK-T
UTS
Specialized Machine
Related Equipment
Bush & Chamfering Drill
Milling Chuck

Collet Holder

"R"-Zero Holder

Hydraulic Chuck

Shrink Fit

Tapping Chuck

Arbors

Function Holder

Turning Tool

Retention Stud

Tool Shank Dimensions